



T-STATION 85 INSTRUCTION MANUAL

Publication Number: D395-94-880

Issue: A

Original Instructions



FOR SALES AND SERVICE PLEASE CALL:

PTB SALES T :: 626.334.0500
service@ptbsales.com
www.ptbsales.com

DATE SERVICED: _____

VIEW OUR INVENTORY

Copyright notice

©Edwards Limited 2017. All rights reserved.

Trademark credits

Edwards and the Edwards logo are trademarks of Edwards Limited.

Associated publications

A746-02-885 *Diaphragm Pump - XDD1*

A371-32-880 *Rotary Vane Pump - E2M0.7 / E2M1.5*

B8G0-00-880 *Turbomolecular Pumps - nEXT85*

Declaration of Conformity

We, Edwards,
Innovation Drive,
Burgess Hill,
West Sussex,
RH15 9TW, UK

declare under our sole responsibility, as manufacturer and person within the EU authorised to assemble the technical file, that the product(s)

T-Station 85

T S 8 5 - X X - 0 X X

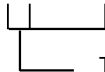

The material numbers cover a family of products where the following features may vary:- turbomolecular pump inlet flanges, electrical supply and backing pumps.

Backing pumps:
E2M1.5
XDD1

to which this declaration relates is in conformity with the following standard(s) or other normative document(s)

ENISO12100:2010	Safety of machinery. General principles for design. Risk assessment and risk reduction
EN61010-1: 2010	Safety Requirements for Electrical Equipment for Measurement, Control and Laboratory Use. General Requirements
EN61326-1:2013 (Class B Emissions, Industrial Immunity)	Electrical equipment for measurement, control and laboratory Use. EMC requirements. General requirements

and fulfils all the relevant provisions of

2006/42/EC	Machinery Directive
2014/35/EU	Low Voltage Directive
2014/30/EU	Electromagnetic Compatibility (EMC) Directive
2011/65/EU	Restriction of Certain Hazardous Substances (RoHS) Directive

Note: This declaration covers all product serial numbers from the date this Declaration was signed onwards.

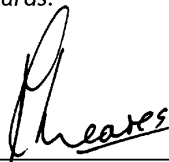

Mr Peter Meares, Senior Technical Support Manager

01.11.2016, Burgess Hill
Date and Place

This product has been manufactured under a quality management system certified to ISO 9001:2008

Material Declaration

In accordance with the requirements of the Chinese regulatory requirement on the Management Methods for the Restriction of the Use of Hazardous Substances in Electrical and Electronic Products Order No. 32 (also known as 'China RoHS2') and SJ/T 11364 Marking for the Restricted Use of Hazardous Substances in Electronic and Electrical Products:

Product Labels

Product	Product Label	Meaning
All pumps in the list below		This product contains hazardous substances in at least one of the homogeneous materials used which are above the limit requirement in GB/T 26572 as detailed in the declaration table below. These parts can safely be used for the environmental protection use period as indicated.

Pump Type	Pump Size
RV Pumps	RV3, 5, 8, 12, E Lab, nRVi
EM Small Pumps	E2M0.7, 1.5, E1M18, E2M18, 28, 30, nE2M40i
nEXT Pumps	nEXT 85, 240, 300, 400, Splitflow
nXDS pumps	nXDS 6, 10, 15, 20
EXT pumps	EXT75DX
XDS pumps	XDS35, 46, 100
Diaphragm	XDD 1, D Lab
Turbo Pump Carts	T station, nEXT station

材料成分声明

Materials Content Declaration





部件名称 Part name	危□物□					
	铅 Lead (Pb)	汞 Mercury (Hg)	镉 Cadmium (Cd)	六价铬 Hexavalent Chromium (Cr VI)	多溴联苯 Polybrominated biphenyls (PBB)	多溴二苯醚 Polybrominated diphenyl ethers (PBDE)
铸铝 Cast Aluminium	X	O	O	O	O	O
铜管管件 Brass pipe Fittings	X	O	O	O	O	O
铜接头 Brass Connectors	X	O	O	O	O	O

O : 表示该有害物质在该部件的所有均质材料中的含量低于 GB/T 26572 标准规定的限量要求。
O: Indicates that the hazardous substance contained in all of the homogeneous materials for this part is below the limit requirement in GB/T 26572.

X : 表示该有害物质在该部件的至少一种均质材料中的含量超出 GB/T26572 标准规定的限量要求。
X: Indicates that the hazardous substance contained in at least one of the homogeneous materials used for this part is above the limit requirement of GB/T26572.

NOTES: These products are EU RoHS compliant, the following Exemptions apply:
6(b) Lead as an alloying element in aluminium containing up to 0.4% by weight.
6(c) Copper alloy containing up to 4% lead by weight

Packaging Information

Pallet	Over-shipper	Protection Pieces	Support Braces
			
Recyclable Natural Wood	Recyclable Cardboard	Recyclable Polypropylene	Recyclable Mild Steel

Contents

Copyright notice.....	2
Trademark credits.....	2
Associated publications.....	2
List of Figures.....	7
List of Tables.....	8
Safety and compliance	9
Definition of Warnings and Cautions.....	9
Safety symbols.....	9
General description	10
Overview.....	10
Installation	11
Installation safety.....	11
Unpack and inspect.....	11
Locate the T-Station 85	12
Bench top fixing.....	12
Fill the pump with oil.....	12
Connect to the vacuum system.....	13
Connect to the exhaust extraction system.....	13
Connect the electrical supply.....	14
Configure the T-Station 85	14
Turbo pump delay.....	14
Connect a vacuum gauge.....	15
Commission the installation.....	15
Operation	16
Control panel description.....	16
Start up.....	17
Menu structure.....	17
Turbo screen.....	18
Gauge screen.....	19
Vent valve screen.....	20
Turbo setpoint screen.....	22
Calibrate gauge screen.....	23
Units screen.....	24
Gas ballast control (E2M1.5).....	25
Electrical supply failure.....	25
Maintenance	26
Maintenance safety.....	26
Maintenance plan.....	26
Inspect the hoses, pipelines and connections.....	27
Factory default settings.....	27

Fault finding	28
The T-Station 85 has failed to start.....	28
Ultimate pressure cannot be reached.....	28
The backing pump is noisy.....	28
The backing pump is leaking oil.....	28
The turbo pump is very noisy or there is excessive vibration or both.....	29
Error numbers.....	29
Storage	31
Disposal	32
Service	33
Spares	34
Accessories	35
TAV vent valve and vent port adaptor (for nEXT85 turbo pump).....	35
Outlet mist filter(for E2M1.5 rotary vacuum pump).....	35
Technical Reference	36
Operating and storage conditions.....	36
Mechanical data.....	36
Pump performance data.....	37
Pumped media.....	38
Venting gas specification and vent control data.....	39
Materials exposed to gases pumped.....	40
Electrical connections.....	40
Electrical data.....	42

List of Figures

Figure 1: General view of the T-Station 85.....	10
Figure 2: Turbomolecular pump start delay with XDD1 diaphragm pump.....	15
Figure 3: Front panel display.....	16
Figure 4: Menu structure.....	18
Figure 5: Turbo screen.....	19
Figure 6: Gauge screen.....	20
Figure 7: Vent valve screen.....	21
Figure 8: Turbo setpoint screen.....	22
Figure 9: Turbo setpoint number entry mode.....	23
Figure 10: Calibrate gauge screen.....	24
Figure 11: Units screen.....	24
Figure 12: Dimensions - T-Station 85.....	37
Figure 13: Max allowed rate of pressure rise during venting: pressure against time (pump initially at full speed).....	40
Figure 14: Pin connections for 15-way sub-miniature 'D' type socket.....	41
Figure 15: Pin connections for an 8-way RJ45.....	42
Figure 16: HS1 Form.....	43
Figure 17: HS2 Form.....	44

List of Tables

Table 1: Checklist of items.....	11
Table 2: Front panel symbols and their functionsl.....	16
Table 3: Menu items.....	17
Table 4: Turbo screen key actions.....	19
Table 5: Gauge screen key actions.....	20
Table 6: Vent valve screen.....	21
Table 7: Vent valve screen key actions.....	21
Table 8: Turbo setpoint screen key actions.....	23
Table 9: Calibrate gauge screen key actions.....	24
Table 10: Units screen key actions.....	24
Table 11: Error numbers.....	29
Table 12: TAV vent valve kits and adaptor.....	35
Table 13: Outlet mist filter.....	35
Table 14: Operating and storage conditions.....	36
Table 15: Mechanical data.....	36
Table 16: Pump performance data - nEXT85H.....	37
Table 17: Pump performance data - nEXT85D.....	38
Table 18: Vent gas specification and vent control.....	39
Table 19: Electrical connections.....	40
Table 20: Turbo pump connector pin-out.....	41
Table 21: Active gauge connector pin-out.....	42
Table 22: Electrical data.....	42

Safety and compliance

Definition of Warnings and Cautions

Important safety information is highlighted as WARNING and CAUTION instructions; these instructions must be obeyed.

The use of WARNINGS and CAUTIONS is defined below.



WARNING:

Warnings are given where failure to observe the instruction could result in injury or death to people. The actual symbol shown varies according to the hazard.





CAUTION:

Cautions are given where failure to observe the instruction could result in damage to the equipment, associated equipment or process.

Safety symbols

The safety symbols on the products denote areas where care and attention is required.

The following safety symbols may be used on the T-Station 85 or throughout the product documentation.

	<p>Warning/Caution</p> <p>An appropriate safety instruction should be followed or caution to a potential hazard exists.</p>
	<p>Warning - Dangerous Voltage</p> <p>Indicates hazards arising from dangerous voltages.</p>
	<p>Warning - Hot Surfaces</p> <p>Indicates that the marked item may be hot and should not be touched without taking precautions.</p>

General description

For the general description of the major components used on the T-Station 85, select the appropriate instruction manual reference against each product type.

Diaphragm pump	XDD1	A746-02-885
Rotary vane pumps	E2M0.7 / E2M1.5	A371-32-880
Turbomolecular pumps	nEXT85	B8G0-00-880

Overview

The T-Station 85 is a small compact fully automatic pumping system which is suitable for a wide range of vacuum applications.

The T-Station 85 can be supplied with either an XDD1 oil free diaphragm pump or an E2M1.5 rotary vane pump. Both system variants use a nEXT85 turbomolecular pump.

The T-Station 85 is controlled by an easy to use touch pad control module. A single gauge input included can be connected to a range of Edwards active gauges allowing for pressure measurement and/or control management of the turbomolecular pump.

The compact size of the T-Station 85 is ideal for use on bench tops or suitable mobile platforms. The open system configuration allows easy maintenance of the main pump components.

Figure 1 General view of the T-Station 85

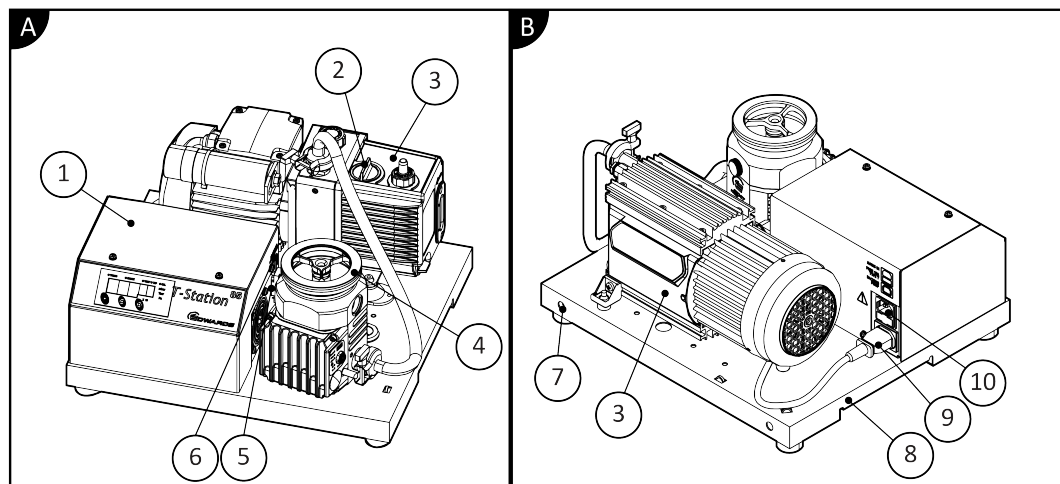

A. Front view (T-Station with E2M1.5 backing pump option)

B. Rear view (T-Station with XDD1 backing pump option)

- | | |
|----------------------------------|---|
| 1. T-Station control unit | 6. Vacuum gauge input |
| 2. E2M1.5 gas ballast control | 7. T-Station fixing points for bench top mounting |
| 3. Backing pump | 8. T-Station lifting handles |
| 4. Turbomolecular pump inlet | 9. Backing pump mains connector |
| 5. Turbomolecular pump connector | 10. Mains input |

Installation

Installation safety



WARNING:

Risk of injury or damage to equipment. Follow the safety instructions and take note of all appropriate precautions.

- When referring to a manual supplied as a Supplementary Publication, all of the WARNING and CAUTION instructions in the manual must be obeyed.
- A suitably trained and supervised technician must install the T-Station 85.
- Check that all the required parts are available and of the correct type before commencing work.
- Ensure that the installation technician is familiar with the safety procedures which relate to the products pumped.
- Wear the appropriate safety clothing when coming into contact with contaminated components.
- Isolate the other components in the system from the electrical supply so that they cannot be operated accidentally.
- Do not reuse O-rings and co-seals if they are damaged.
- Dispose of components, grease and oil safely (refer to *Disposal* on page 32).
- Take care to protect sealing faces from damage.
- Leak testing the system after installation is complete to ensure optimum vacuum performance is recommended.

Unpack and inspect

1. Remove the outer cover and all packing materials, remove the protective covers from the inlet and outlet ports, inspect the system for any damage.
2. If the T-Station 85 is damaged, notify the supplier and the carrier in writing within three days; state the item number of the T-Station 85 together with the order number and the supplier's invoice number. Retain all packing materials for inspection. Do not use the pump if it is damaged.
3. Check that the package contains the items listed in *Table 1* on page 11. If any of these items are missing, notify the supplier in writing within three days.
4. If the pump is not to be used immediately, replace the protective covers and store in suitable conditions as described in *Storage* on page 31.

Table 1 Checklist of items

Quantity	Description	Check
1	T-Station 85	<input type="checkbox"/>
1	CD instruction manual P450-00-000	<input type="checkbox"/>
1	Ultragrade 15 oil 1 litre (supplied with E2M1.5 only)	<input type="checkbox"/>
1	Inlet seal (either trapped O-ring, co-seal or copper compression gasket suitable for the inlet flange type)	<input type="checkbox"/>

Locate the T-Station 85



WARNING:

Heavy objects can cause muscle strain or back injury. The mass of the T-Station 85 will differ depending on the model supplied.



WARNING:

The turbo pump used on the T-Station 85 stores a large amount of kinetic energy when it is running at full speed. In the unlikely event of a malfunction (rotor seizure), the stored energy could cause a slight movement of the T-Station 85 platform. If the T-Station 85 is operating on a bench top, taking the following steps is advised: (a) Position the T-Station 85 at least 10-15 cm away from the edge of the bench top and adjacent devices and/or (b) Tether or fix the T-Station 85 to the bench top, see [Bench top fixing](#) on page 12.



CAUTION:

When locating the T-Station 85, care should be taken not to restrict the ventilation grid located under the base of the system. Failing to observe this may result in overheating of the turbomolecular pump.

Bench top fixing

There are two M8 fixing points located at the rear of the T-Station 85 base ([Figure 1](#) on page 10, item 7). Using suitable brackets or straps (not supplied), securing the T-Station 85 to the bench top is recommended to prevent excessive movement in the unlikely event of a pump failure.



Note:

Straps or brackets cannot be provided as the best type fixing for the customer bench top location cannot be determined. Sourcing or fabricating these fixings locally is recommended.

Fill the pump with oil

Procedure for filling the pump with the recommended oil.

If the T-Station 85 uses an E2M1.5 rotary vane pump, it must be filled with the correct quantity of oil (supplied) before operating the equipment. For further information refer to the EM Rotary Vane Pump manual A371-32-880.

Fill the pump with oil as follows:

1. Remove the oil filler plug.
2. Pour oil into the pump until the oil level just reaches the MAX mark on the bezel at the top of the sight glass. If the oil level goes above the MAX mark, remove the drain plug and drain the excess oil from the pump.
3. After a few minutes, recheck the oil level. If the oil level is now below the MAX mark, pour more oil into the pump.
4. Refit the oil filler plug. Tighten the plug firmly by hand. Do not over tighten.

Connect to the vacuum system



WARNING:

Connect the turbo pump inlet to the vacuum system before applying power to the T-Station 85. This will ensure that the pump cannot operate accidentally causing injury.



WARNING:

If installing the vacuum system directly onto the T-Station 85, the weight of the system must be no more than 10 kg and the centre of gravity must be positioned laterally within the bounds of the base plate. If this is not the case, the vacuum system must be supported to ensure that the T-Station 85 does not topple.

1. The turbo pump can be securely fixed to the vacuum system via the inlet flange. Make sure that the pump inlet and all components fitted to the pump inlet are clean and dust-free. If the pump inlet is not kept clean, the pump down time may be increased.
2. If the pump has a CF flange, use the copper compression gasket supplied with the pump and use a full complement of bolts to connect the inlet flange of the pump to the vacuum system.
3. If the pump has an ISO flange, use a minimum of four claw clamps (each torqued to 10 Nm) to connect the inlet flange of the pump to the vacuum system. Alternatively, use a rotatable collar and the combined inlet screen and trapped O-ring supplied with the pump to connect the inlet flange of the pump to the vacuum system; use a full complement of bolts with the rotatable collar.
4. If the pump has an NW flange, use the centring ring supplied with the pump and a metal NW clamp to connect the inlet flange of the pump to the vacuum system.
5. All inlet flange bolts must be re-tightened once the system is under vacuum. Ensure that no torques or other forces are transmitted to the pump from the vacuum system or the associated pipelines.

Connect to the exhaust extraction system



WARNING:

Vent dangerous gases and gas mixtures safely. Do not expose people to these gases. If pumping hazardous gases or vapours, observe the safety recommendations of the supplier of the gas/vapour.



Note:

This section applies to E2M1.5 versions only.

The exhaust system must be configured so that the maximum pressure at the pump outlet does not exceed 0.5 bar gauge (1.5 bar absolute, 1.5×10^5 Pa) at full pump throughput.

1. Make sure that the exhaust pipeline cannot become blocked.
2. If using an exhaust isolation valve, make sure the pump cannot be operated with the valve closed.

Connect the electrical supply



WARNING:

Ensure that the electrical installation of the pump conforms with all local and national safety requirements. It must be connected to a suitably fused and protected electrical supply with a suitable earth point.



CAUTION:

Always make the electrical connections to the T-Station 85 after the equipment has been installed on the vacuum system. Always disconnect the electrical supply from the T-Station 85 before removing the equipment from the vacuum system.

Check that the electrical supply is suitable for this equipment. Refer to [Table 22](#) on page 42 for the electrical requirements for this equipment.

Make the electrical connection to the T-Station 85 using a cable fitted with an IEC60320 connector.

A range of suitable cables is available from the supplier.

Configure the T-Station 85

As supplied from the factory, the T-Station 85 will control the system as follows:

System start is selected:

- The TAV vent valve will close.
- The backing pump will turn on.
- The turbomolecular pump will start accelerating up to full rotational speed.

System off is selected:

- The backing pump will turn off.
- The turbomolecular pump drive will turn off and the pump will start to decelerate.
- The TAV vent valve will open fully from 50% of full rotational speed.

Turbo pump delay

The T-Station 85 can be configured to delay the turbo pump after the backing pump has started.

Refer to [Turbo setpoint screen](#) on page 22. The delay is helpful to prevent the turbomolecular pump from accelerating under high pressure for a prolonged period if the volume being pumped is greater than 2 litres. This option is especially useful if the T-Station 85 uses an XDD1 diaphragm pump.

[Figure 2](#) on page 15 shows the recommended delay period for a turbo / XDD1 pump combination.

* This operation refers to systems which have been fitted with an Edwards TAV vent valve (optional accessory). For more vent options refer to [Vent valve screen](#) on page 20.

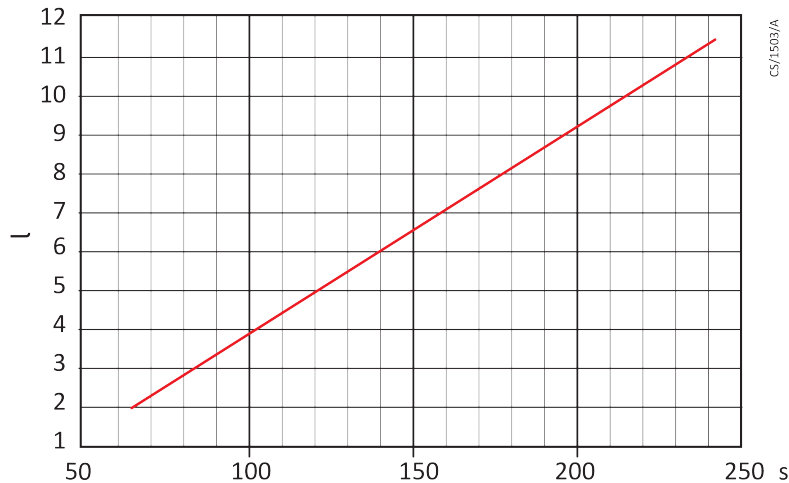
Figure 2 Turbomolecular pump start delay with XDD1 diaphragm pump

Connect a vacuum gauge

A single compatible active gauge can be fitted to the T-Station 85.

Fit the gauge using an Edwards active gauge cable into the gauge connector located on the side of the controller housing (refer to [Figure 1](#) on page 10, item 6). For active gauge control and set up refer to [Gauge screen](#) on page 19.

The following Edwards active gauges are suitable for use with the T-Station 85:

- APG100 Active Pirani vacuum gauge
- APGX-H Active Linear Convection gauge
- AIM-X Active Inverted Magnetron gauge
- ASG Active Strain gauge

Commission the installation

After installing the T-Station 85, the system must be tested.

Use the following procedure to test the system:

1. Make sure that all the electrical connections are secure.
2. Switch on the electrical supply and the exhaust extraction system (if available).
3. To operate the system press the START/STOP key. Check that the equipment operates as described in .
4. Check that the turbo pump reaches normal speed. If the pump inlet is valved or capped off, it should take approximately 100 - 150 seconds for the turbo to reach normal speed. If a vacuum chamber is attached to the pump inlet, this time may take longer.
5. To turn OFF the system, press the START/STOP key followed by the ENTER key to confirm. Check that the equipment closes down as described in .

For full operational details and how to navigate using the front panel control key pad refer to [Menu structure](#) on page 17.

Operation



WARNING:

Do not attempt to move the T-Station 85 while the turbo pump is rotating. Doing so may cause severe damage to the pump and could cause injury.



CAUTION:

To familiarise yourself with the vacuum pumps installed on the T-Station 85, it is advisable to read the relevant instruction manuals (refer to [General description](#) on page 10).

Control panel description

Figure 3 Front panel display

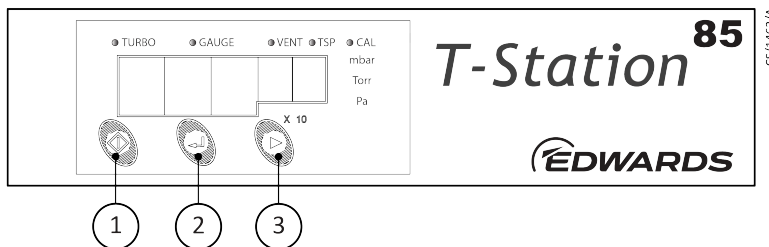

1. Start/ Stop
2. Enter
3. Next

Table 2 Front panel symbols and their functions

Key pad symbol	Name	Function
1	START/STOP	Turns the pumps on and off. Returns to turbo menu screen.
2	ENTER	Selects or confirms current menu option. Controls active gauges.
3	NEXT	Moves to next menu. Scrolls through menu options.

The LEDs along the top of the T-Station 85 display indicate which menu screen is currently being shown on the numeric display. To move to the next menu item press the NEXT key and to return to the turbo menu screen press the START/STOP key. The available items are listed in order in [Table 3](#) on page 17.

Table 3 Menu items

Turbo screen
Gauge screen
Vent valve screen
Turbo setpoint (TSP) screen
Calibrate gauge screen
Units screen

Start up

When applying power to the T-Station 85 all LEDs in the display will light for 2 seconds to confirm operation. The software version will then be displayed for a further 2 seconds. If you need to contact Edwards for support regarding the T-Station 85, please have this software version number available.

Menu structure

Figure 4 on page 18 shows the view screen shortcuts and menu structure for the T-Station 85 control display. They also give an indication as to where buttons will take you within the menu layout.

Figure 4 Menu structure

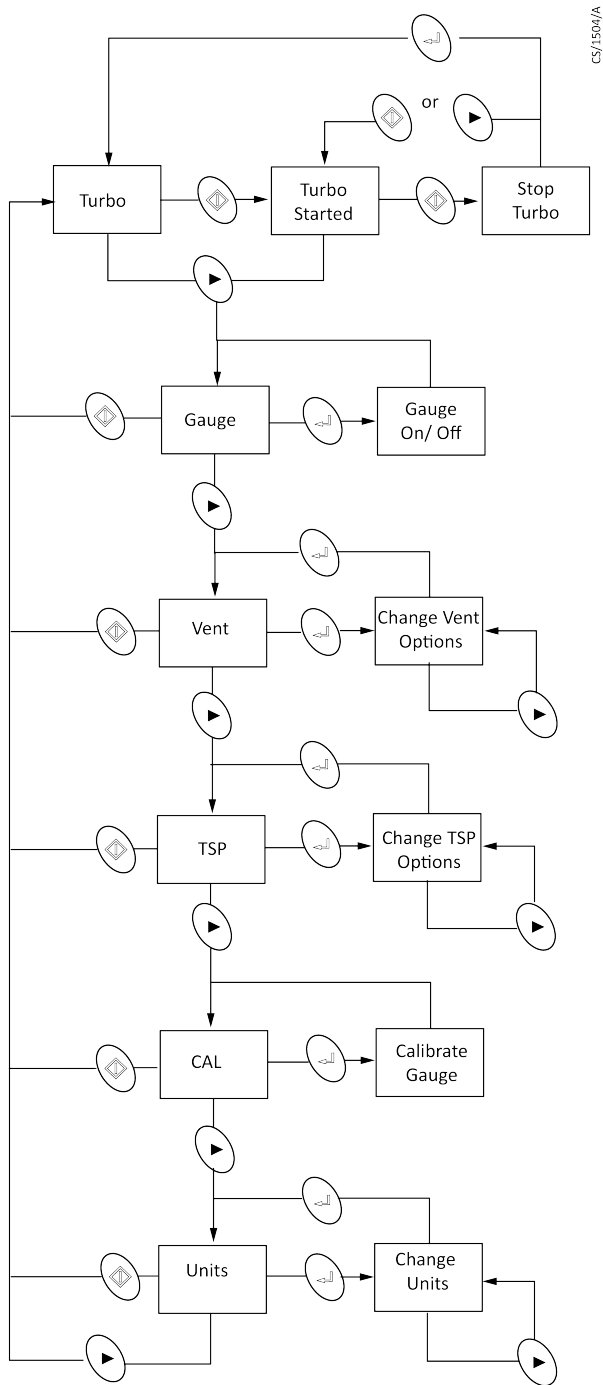

Turbo screen

When the turbo screen is selected, the turbo LED is lit and the speed of the turbomolecular pump is displayed in percentage of full speed.

If no turbo pump is connected the display shows "---".

Figure 5 Turbo screen

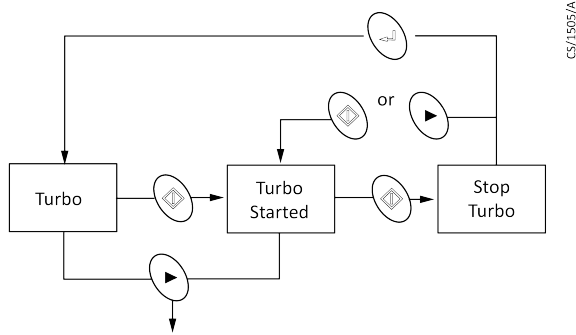

Start the pump with the turbo screen

When the START/STOP key is pressed, both the turbo and backing pumps start. The display shows the turbo pump is accelerating by flashing the top left portion of the percentage sign. When the turbo pump reaches normal speed (>80% default) the percentage sign stops flashing and remains steady.

If a turbo setpoint (TSP) has been set, only the backing pump starts when the START/STOP key is pressed. The TSP LED flashes until the setpoint has been reached. Once the setpoint has been reached the turbo pump starts and the TSP LED turns OFF. If no turbo setpoint has been set, the TSP LED remains OFF.

Stop the pump with the turbo screen

1. To stop the pumps press the START/STOP key; the display will show "Stop" for three seconds.
2. Press the ENTER key within that time to stop the pumps. If the ENTER key has not been pressed, or the START/STOP or NEXT keys are pressed, the display shows the turbo pump speed and the pumps remain running.

When the turbo pump is decelerating the bottom right portion of the percentage sign flashes until the pump has completely stopped.

Turbo screen key actions

Table 4 Turbo screen key actions

Keys	Short press	Long press
START	START the turbo, or initialise turbo STOP sequence, or cancel turbo STOP, or force turbo STOP when in error	-
ENTER	Acknowledge turbo STOP	Fault code display when in error
NEXT	Go to gauge screen, or cancel turbo STOP	Scroll through menu screens

Gauge screen

When the gauge screen is selected, the gauge LED is lit and the gauge pressure reading is displayed in the selected units.

If no gauge is connected the display shows "---".

Connect a gauge

When a gauge is first connected the display shows "ID" followed by a number to identify the new gauge.

If the gauge is an Active Strain Gauge (ASG), the display then goes to ASG range select, otherwise the display reverts to showing the pressure reading. If the gauge type is not supported the display shows "???". When no gauge is connected the display shows "---".

Figure 6 Gauge screen

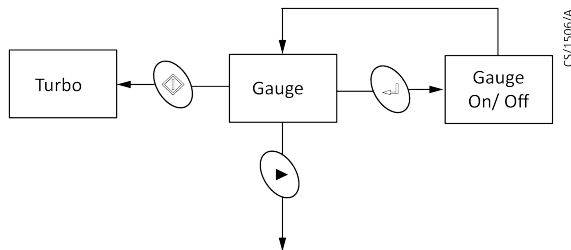

ASG range select

When an ASG is connected the display changes to select the ASG range. 1000 mbar is assumed by default, and the display flashes "1.0³".

Press the NEXT key to select between 1000 and 2000 mbar, then press the ENTER key to confirmed the selection.

Gauge ON/OFF control

Gauges which support ON/OFF control (e.g. AIM gauges) can be turned ON and OFF using the ENTER key.

When first connected the gauge is in the OFF state and the display shows "OFF". When the gauge is turned on the display will show "Str" whilst the gauge is starting up, and will then display pressure.

Gauge screen key actions

Table 5 Gauge screen key actions

Keys	Short press	Long press
START	Go to turbo screen	-
ENTER	ON/OFF control of supported gauge or acknowledge error	-
NEXT	Go to vent control screen	Scroll through menu screens

Vent valve screen

If a TAV solenoid vent valve is connected to the turbo pump podule the operation of the valve is controlled by the vent valve screen.

When the vent valve screen is selected, the vent LED is lit and the current vent valve control setting is displayed. The default is "50%". The vent valve screen is not available if the turbo pump is running.

1. Select the appropriate setting for either normally open or normally closed vent valve.

2. To change the vent valve setting press the ENTER key, then use the NEXT key to choose between 50%, CtrlId and FAN.
3. Press the ENTER key again to confirm the selection.

Table 6 Vent valve screen

50 no	Normally open vent valves. Vent valve opens fully when the speed of the turbo pump drops below 50% full rotational speed.
Ctrl no	Normally open vent valves. Controlled venting from 100% to 50% full rotational speed; vent valve opens fully below 50%.
Fan	Normally open vent valves. The vent valve connection on the turbo pump is permanently powered so that the vent valve will remain closed. This can also be used to provide power to an air cooler (for example, ACX75).
Off	Normally closed vent valves. The vent valve connection on the turbo pump is permanently disabled so the vent valve will remain closed.
50 nc	Normally closed vent valves. The vent valve will open when the speed of the turbo pump has dropped below 50% during stop but not fail conditions.
Ctrl nc	Normally closed vent valves. Controlled venting from 100% to 50% full rotational speed, vent valve opens fully below 50% during stop but not fail conditions.

Figure 7 Vent valve screen

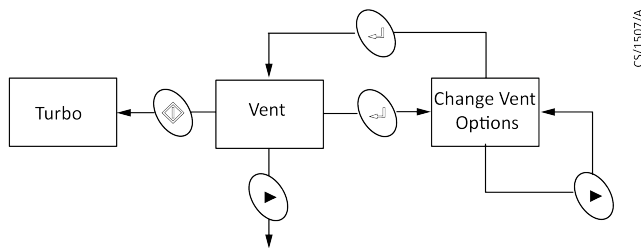

Vent valve screen key actions

Table 7 Vent valve screen key actions

Keys	Short press	Long press
START	Go to turbo screen	-
ENTER	Enter edit mode, or confirm selection	-
NEXT	Next vent option, or go to TSP control screen	Scroll through vent options in edit mode or scroll through menu screens

Turbo setpoint screen

The turbo setpoint screen is used to configure the start delay of the turbo pump.

When the turbo setpoint screen is selected, the TSP LED is lit and the current setpoint is displayed. The default is "OFF". The turbo setpoint menu is not available if the turbo pump is running or the selected units are volts.

1. To change the turbo setpoint press the ENTER key, then use the NEXT key to choose between off, time delay and pressure setpoint.
2. Press the ENTER key again to confirm the selection.
3. When time delay is selected the display will show the delay time in seconds. The default time is 120 s. This means that the turbo pump will start after a delay of 120 s from when the START key is pressed. To change the value of the delay time press and hold the ENTER key to start number entry mode.
4. If an active gauge is connected to the system the pressure setpoint can be used to start the turbo pump once the pressure has fallen below the setpoint value. When pressure is selected the display shows the setpoint pressure. The default pressure is "5.0⁰" mbar shown as an exponential. To change the pressure setpoint, press and hold the ENTER key to start number entry mode.



Note:

If the turbo setpoint is set to pressure but a gauge is not connected the turbo pump will not start.

Figure 8 Turbo setpoint screen

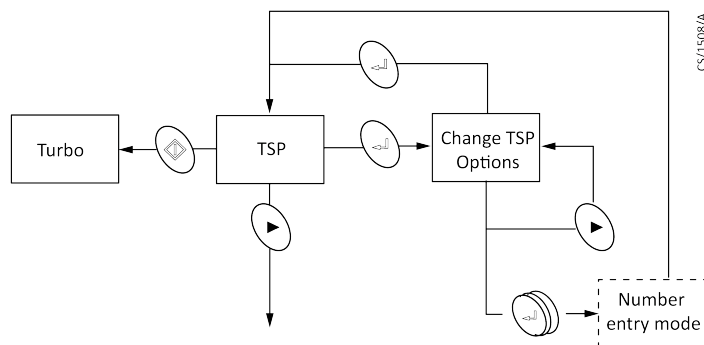

Number entry mode

When the ENTER key is pressed and held on either the time or pressure option, number entry mode is entered. The first digit starts flashing and the time or pressure can be edited.

1. Press the NEXT key to adjust the value, then press the ENTER key to confirm the digit and then move on to the second digit, which is adjusted similarly. The ENTER key confirms the digit and then moves to the final digit of the time setpoint or the exponent of the pressure setpoint. The exponent of the pressure setpoint is adjusted as a single value in the range - 10 to + 6.
2. The final press of ENTER confirms the complete number and returns to showing the setpoint value. The TSP is set after the complete number is entered.

Figure 9 Turbo setpoint number entry mode

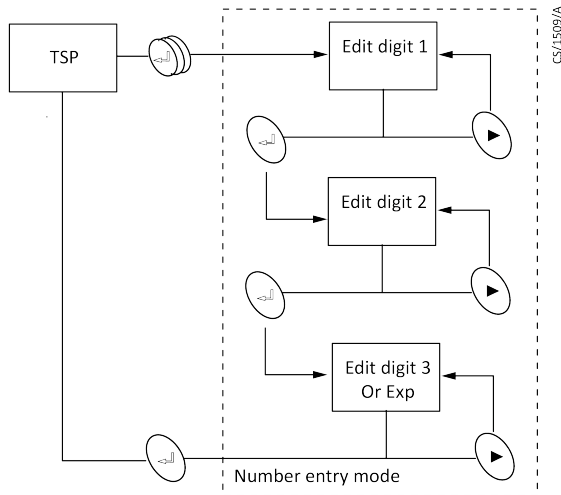

Turbo setpoint screen key actions

Table 8 Turbo setpoint screen key actions

Keys	Short press	Long press
START	Go to turbo screen	-
ENTER	Enter edit mode, or confirm selection	Enter number entry mode
NEXT	Next TSP option, next number or go to gauge calibration screen	Scroll through TSP options in edit mode, scroll through numbers in number entry or scroll through menu screens

Calibrate gauge screen

When the calibrate gauge screen is selected, the gauge LED and the CAL LED are lit together. The numeric display is blank. The calibrate gauge menu is not available for gauges which do not support calibration.

When the ENTER key is pressed the action depends on gauge type:

WRG or APGX: The calibration command is sent to the gauge and the display shows "CALd" for 3 seconds.

ASG: The calibration functions as a zero offset adjustment. The pressure currently displayed is saved as the zero offset and is subtracted from all future readings. The display shows "CALd" for 3 seconds to confirm the action. The offset adjustment can be cancelled by pressing the ENTER key again. The display shows "OFF" for 3 seconds to confirm that the offset adjustment has been removed.

Figure 10 Calibrate gauge screen

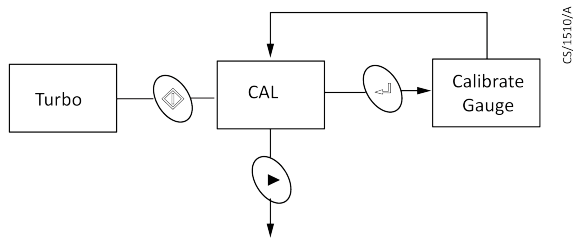

Calibrate gauge screen key actions

Table 9 Calibrate gauge screen key actions

Keys	Short press	Long press
START	Go to turbo screen	-
ENTER	Calibrate gauge	-
NEXT	Go to units screen	Scroll through menu screens

Units screen

When the units screen is selected, the menu LEDs are unlit and the currently selected units LED is lit. The numeric display is blank.

To change the units press the ENTER key and use the NEXT key to choose between mbar, Torr, Pa and voltage. Press the ENTER key again to confirm the selection. Note that when voltage is selected the display shows " 0.000".

When the units are changed, the setpoint values will be converted to the new units. For example, if a setpoint threshold is entered as 1.0×10^{-3} mbar and the units are changed to Torr, then the value will be displayed as 7.5×10^{-4} Torr.

Figure 11 Units screen

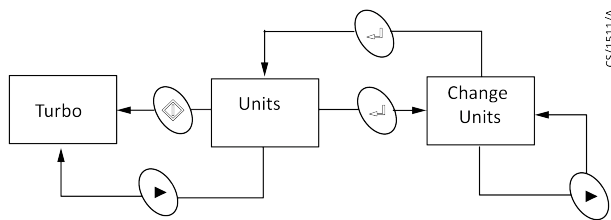

Units screen key actions

Table 10 Units screen key actions

Keys	Short press	Long press
START	Go to turbo screen	-
ENTER	Enter edit mode, or confirm selection	-
NEXT	Next units option, or go to turbo screen	Scroll through units in edit mode, or scroll through menu screens

Gas ballast control (E2M1.5)

Use the gas ballast control to change the amount of air (or inert gas) introduced into the low vacuum stage of the pump.

Use of the gas ballast will prevent the condensation of vapours in the pump; the condensates would contaminate the oil.

Use the gas ballast control (*Figure 1* on page 10, item 2) closed:

- to achieve ultimate vacuum
- to pump dry gases.

Turn the gas ballast control six turns anti-clockwise to open it fully.

Use the gas ballast control open:

- to pump high concentrations of condensable vapour
- to pump high concentrations of condensable vapour

When operating the pump with the gas ballast control open, there will be an increased rate of oil loss from the pump.

Electrical supply failure



WARNING:

Risk of injury or death. If the power supply fails when the pump is running, the impeller could continue to spin for approximately 10 minutes. The control circuit may not give any indication that the impeller is still running.

If the electrical supply to the T-Station 85 fails when the turbo pump is rotating, the motor of the turbo pump is used as a generator. The regenerated power is used to maintain the control system and the display. The regenerated power is not used to maintain the T-Station 85 control system or the display.

When power to the control system is lost, no indication will be given about pump rotational speed, yet the impeller may still be turning.

The system will not restart when the power is reinstated.

Maintenance

Maintenance safety



WARNING:

Risk of injury or damage to equipment. Follow the safety instructions and take note of all appropriate precautions.

- When referring to a manual supplied as a Supplementary Publication, all of the WARNING and CAUTION instructions in the manual must be obeyed.
- A suitably trained and supervised technician must maintain the T-Station 85.
- Allow the system to cool (so that it is at a safe temperature for skin contact) before starting maintenance work. Make sure the system is switched off in case the thermal overload device restarts the system.
- Check that all the required parts are available and of the correct type before starting work.
- Ensure that the maintenance technician is familiar with the safety procedures which relate to the pump oil and the products processed by the pumping system.
- Isolate the system and other components from the electrical supply so that they cannot be operated accidentally.
- Do not reuse O-rings and seals if they are damaged.
- Dispose of components, grease and oil safely (refer to *Disposal* on page 32).
- Protect sealing faces from damage.
- Leak testing the system is recommended after maintenance. Seal any leaks found if any vacuum or exhaust pipeline connections have been disconnected.

Maintenance plan



WARNING:

If the turbo pump is removed from the T-Station 85 platform, it is important to retain and reuse the same fixing screws. If any of these screws are lost or cannot be used, the following type M5 x 12 mm CAP HD high tensile class 12.9 must be used. If this warning is ignored and the turbo pump seizes, the stored energy in the turbo pump may cause some or all of the screws to fail. This may result in the turbo pump being ejected from the T-Station 85 base.

List of instruction manuals that state the minimum maintenance operations necessary to maintain the T-Station 85 in normal use:

Diaphragm pump	XDD1	A746-02-885
Rotary vane pumps	E2M0.7 / E2M1.5	A371-32-880
Turbomolecular pumps	nEXT85	B8G0-00-880

More frequent maintenance may be necessary if the T-Station 85 has been used to pump corrosive or abrasive gases and vapour. If necessary, adjust the maintenance plan according to your experience.

Inspect the hoses, pipelines and connections

1. Inspect all of the electrical connections and check that they are secure. Tighten any loose connections.
2. Inspect all of the electrical cables and check that they are not damaged and have not overheated. Replace or repair any damaged or overheated cable.
3. Inspect all of the vacuum and exhaust connections and check that they are secure. Tighten any loose connections.
4. Inspect all of the vacuum and exhaust pipelines and check that they are not corroded or damaged and that they do not leak. Replace or repair any corroded or damaged component and seal any leaks found.

Factory default settings

Procedure to return the T-Station 85 to the factory default settings.

1. Remove the mains power from the T-Station 85.
2. Press the NEXT key and hold it down whilst reapplying mains power. Continue holding down the NEXT key until "Err01" is displayed.
3. Remove and reapply mains power. The factory defaults will now be set.

Fault finding

The T-Station 85 has failed to start

Cause The electrical supply fuse has blown.

Remedy Replace the fuse. Refer to [Table 19](#) on page 40.

Cause The operating voltage is incorrect.

Remedy Check the voltage supply matches the T-Station 85 voltage requirements. Refer to the electrical rating label located at the rear of the T-Station 85.

Ultimate pressure cannot be reached

Cause Pressure is limited by water vapour.

Remedy Bake the chamber or run the system for a duration until the vacuum improves.

Cause The vacuum gauges are contaminated.

Remedy Clean or replace the vacuum gauges.

Cause Pumping speed is insufficient due to poor conductance between the pump and the gauge or the chamber is too large.

Remedy Increase the conductance or reduce the volume.

Cause The backing pressure is > 10 mbar (1×10^3 Pa).

Remedy The backing pressure may be too high. Check for backing pipeline leaks. If the throughput is high, a larger backing pump may be required.

Cause The high vacuum area of the system is contaminated.

Remedy Clean the high vacuum system.

Cause Check the rest of the system for leaks and contamination.

Remedy If found, repair the leaks and clean the contamination.

Cause The inlet pressure is poor.

Remedy If inlet pressure is poor, check the turbo pump for contamination and refer to the Troubleshooting section of the turbo pump manual.

Leak test the pump. If the leak rate $> 1 \times 10^{-7}$ mbar l s^{-1} (1×10^{-5} Pa l s^{-1}), contact the supplier or Edwards.

The backing pump is noisy

Cause Listed in Fault Finding section of the backing pump manual.

Remedy Refer to the Fault Finding section of the backing pump manual. See [General description](#) on page 10.

The backing pump is leaking oil

Cause Listed in Fault Finding section of the backing pump manual.

Remedy Refer to the Fault Finding section of the backing pump manual. See [General description](#) on page 10.

The turbo pump is very noisy or there is excessive vibration or both

Cause	Listed in Troubleshooting section of the turbo pump manual.
Remedy	Refer to the Troubleshooting section of the turbo pump manual. See General description on page 10.

Error numbers

If an error is detected by the controller the display will show "Err" followed by a number.

Refer to [Table 11](#) on page 29 for a description of the error together with likely causes and suggested remedies.

Table 11 Error numbers

Error Number	Meaning	Possible cause/remedy
Controller errors		
1	EEPROM error	The internal EEPROM checksum has failed. All user settings will revert to the factory default.
2	ID reference error	The reference used for identifying gauges is incorrect. Please remove all connected gauges, turn the electrical supply off and on, and wait for 30 seconds before reconnecting the gauges.
Gauge errors		
11	Gauge voltage too high	The voltage from a gauge is too high. The gauge may be defective.
12	Gauge voltage too low	The voltage from a gauge is too low. The gauge may be defective.
21	WRG Pirani failure	Errors specific to WRG. Refer to the WRG manual for details. Press the ENTER key to clear the error from the display once the fault has been corrected.
22	WRG magnetron short	
23	WRG striker fail	
24	WRG magnetron not struck	
25	APGX filament failure	Errors specific to APGX. Refer to the APGX manual for details. Press the ENTER key to clear the error from the display once the fault has been corrected.
26	APGX cal err	
27	APGXH tube not fitted	

Error Number	Meaning	Possible cause/remedy
Pump errors		
41	Turbo pump fault	Inspect the LEDs on the turbo pump podule for status information. For more detailed fault codes, press and hold the ENTER key (whilst Err41 is showing) to display the turbo pump system status word. The lower 16 bits of the status word are displayed in hexadecimal. Press the START / STOP key to clear the error message. Refer to the instruction manual of the turbo pump for detailed fault finding.

Storage

Use the following procedure to store the T-Station 85.

1. Shut down the T-Station 85 as described in [Stop the pump with the turbo screen](#) on page 19.
2. Isolate the T-Station 85 from the electrical supply and disconnect it from the vacuum system.
3. Drain the oil from the backing pump (only applicable to the E2M1.5 rotary vane pump) as described in the instruction manual, (refer to [General description](#) on page 10).
4. Place protective covers over the inlet and outlet flanges.
5. For the fastest pump down after the T-Station 85 is reinstalled, seal the turbomolecular pump inside a plastic bag together with a suitable desiccant.
6. Store the T-Station 85 in cool, dry conditions until required for use.

Disposal

Dispose of the T-Station 85 and any components and accessories safely and in accordance with all local and national safety and environmental requirements.

Particular care must be taken with any components that have been contaminated with dangerous process substances.

For instruction on draining the oil from the E2M1.5 rotary vane pump refer to the instruction manual for the pump. Refer to [General description](#) on page 10.

Service

**Note:**

Edwards policy is to provide support for product after obsolescence through various options including maintenance, repair, enhancement and replacement. Support will be available for several years after product obsolescence and in compliance with any applicable legislation. Edwards will always undertake appropriate actions to ensure support is maintained and, where support is no longer possible, will ensure this is communicated to all affected customers with a suitable notice period.

Edwards products, spares and accessories are available from Edwards companies in Belgium, Brazil, China, France, Germany, Israel, Italy, Japan, Korea, Singapore, United Kingdom, U.S.A and a world-wide network of distributors. The majority of these centres employ Service Engineers who have undergone comprehensive Edwards training courses.

Order spare parts and accessories from the nearest Edwards company or distributor. When ordering, state for each part required:

- Model and Item Number of the equipment
- Serial number
- Item Number and description of part.

Edwards products are supported by a world-wide network of Edwards Service Centres. Each Service Centre offers a wide range of options including: equipment decontamination; service exchange; repair; rebuild and testing to factory specifications. Equipment which has been serviced, repaired or rebuilt is returned with a full warranty.

Local Service Centres can also provide Edwards engineers to support on-site maintenance, service or repair of equipment. For more information about service options, contact the nearest Service Centre or other Edwards company.

Spares



CAUTION:

Use of non-Edwards spares may result in reduced reliability and performance and will invalidate product warranty.

The spares available for the turbo pump and backing pumps are listed in the CD instruction manuals supplied with your equipment. Refer to [General description](#) on page 10.

Accessories

TAV vent valve and vent port adaptor (for nEXT85 turbo pump)

A solenoid operated vent valve is available for system venting.

The valve is a 24 V d.c., normally-open or normally-closed and can be driven by the turbo pump module. The solenoid valve is fitted in place of the manual valve, or alternatively can be fitted with an adaptor (supplied with the valve) and can be used with any suitable NW10 flanged port on the vacuum system.

Table 12 TAV vent valve kits and adaptor

Description	Item number
nEXT85 TAV5 kit N/C connector fitted (0.3 m)	B8G2-00-835
nEXT85 TAV5 kit N/C bare wire (3 m)	B580-66-040
nEXT85 TAV5 kit N/O connector fitted (0.3 m)	B8G2-00-834
nEXT85 TAV5 kit N/O bare wire (3 m)	B580-66-010
Vent port adaptor NW10 -1/8 inch BSP male	B580-66-011

Outlet mist filter(for E2M1.5 rotary vacuum pump)

The outlet mist filter separates and traps oil droplets in the pump outlet to prevent oil mist discharge.

For all other accessories such as gauges, active cables and mains leads, refer to the T-Station 85 ordering information in the Edwards product catalogue.

Table 13 Outlet mist filter

Description	Item number
EMF3 outlet mist filter	A462-20-000

Technical Reference



Note:

The operating, storage conditions and performance of the T-Station 85 may depend on the type of backing pump fitted to the T-Station 85; refer to the technical data in the appropriate supplementary publications as listed in [General description](#) on page 10.

Operating and storage conditions

Table 14 Operating and storage conditions

Parameter	Value	Units
Ambient operating temperature range	12 to +40	°C
Ambient storage temperature range	-30 to +70	°C
Maximum operating humidity	maximum 90 condensing at 40	% RH and °C
Maximum operating altitude	2000 maximum	m
Sound level	56	dB(A)
Pollution degree (EN61010)	2	-
Maximum outlet pressure - XDD1 pump - E2M1.5 pump	1.1 (1.1 x 10 ⁵) 1.5 (1.5 x 10 ⁵)	bar absolute (Pa)
Maximum permitted external magnetic field (nEXT85 turbo)	5	mT

Mechanical data

Table 15 Mechanical data

Parameter	Data
Dimensions	Refer to Figure 12 on page 37
Degree of protection (to IEC34-5:1981)	IP20
Mass: - XDD1 combination - E2M1.5 combination	17 kg max 21 kg max

Figure 12 Dimensions - T-Station 85

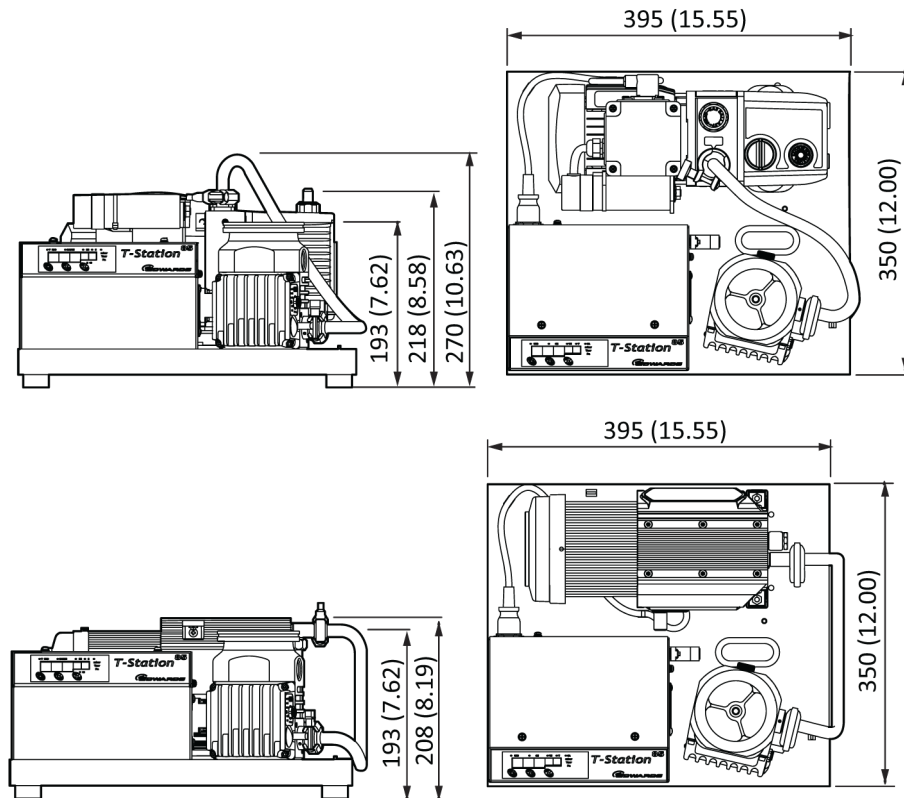

All measurements indicated are shown in mm (inches)

Pump performance data

Table 16 Pump performance data - nEXT85H

Turbomolecular pump type	nEXT85H ISO63	nEXT85H CF63	nEXT85H NW40
Inlet pumping speed:			
Nitrogen	84 ls ⁻¹	84 ls ⁻¹	47 ls ⁻¹
Helium	78 ls ⁻¹	78 ls ⁻¹	61 ls ⁻¹
Hydrogen	54 ls ⁻¹	54 ls ⁻¹	49 ls ⁻¹
Argon	80 ls ⁻¹	80 ls ⁻¹	44 ls ⁻¹
Inlet compression ratio:			
Nitrogen	> 1 E+11	> 1 E+11	> 1 E+11
Helium	2 E+07	2 E+07	2 E+07
Hydrogen	5 E+05	5 E+05	5 E+05
Argon	> 1 E+11	> 1 E+11	> 1 E+11
Ultimate pressure:			
with rotary vane backing pump *	< 5 E-09 mbar	< 5 E-10 mbar	< 5 E-09 mbar
with diaphragm backing pump §	< 5 E-08 mbar	< 5 E-09 mbar	< 5 E-08 mbar

* Ultimate pressure 48 hours after bakeout with 2-stage rotary vane backing pump.

§ Ultimate pressure 48 hours after bakeout with backing pressure < 5 mbar (500 Pa).

Table 17 Pump performance data - nEXT85D

Turbomolecular pump type	nEXT85D ISO63	nEXT85D CF63	nEXT85D NW40
Inlet pumping speed:			
Nitrogen	84 ls ⁻¹	84 ls ⁻¹	47 ls ⁻¹
Helium	78 ls ⁻¹	78 ls ⁻¹	61 ls ⁻¹
Hydrogen	60 ls ⁻¹	60 ls ⁻¹	49 ls ⁻¹
Argon	80 ls ⁻¹	80 ls ⁻¹	44 ls ⁻¹
Inlet compression ratio:			
Nitrogen	> 1 E+11	> 1 E+11	> 1 E+11
Helium	8 E+06	8 E+06	8 E+06
Hydrogen	2 E+05	2 E+05	2 E+05
Argon	> 1 E+11	> 1 E+11	> 1 E+11
Ultimate pressure:			
with rotary vane backing pump *	< 5 E-09 mbar	< 5 E-10 mbar	< 5 E-09 mbar
with diaphragm pump §	< 5 E-08 mbar	< 5 E-09 mbar	< 5 E-08 mbar

* Ultimate pressure 48 hours after bakeout with 2-stage rotary vane backing pump.

§ Ultimate pressure 48 hours after bakeout with backing pressure < 5 mbar (500 Pa).

Pumped media



WARNING:

Vent dangerous gases and gas mixtures safely. Do not expose people to these gases. If pumping hazardous gases or vapours, observe the safety recommendations of the supplier of the gas/vapour.



WARNING:

Do not use the pump to pump pyrophoric or explosive gas mixtures as it is not suitable for this purpose. The pump and its connections are not designed to contain an explosion.



WARNING:

Do not expose any part of the human body to the vacuum as this could result in injury to or death of people.



CAUTION:

Do not use the pump to pump particulates or condensable media. Deposition may occur within the pump which will degrade pump performance and reduce the pump life.

**CAUTION:**

Do not use the pump to pump gases containing more than 20% oxygen. This will cause the lubricant to polymerise and the pump to fail prematurely.

**Note:**

Concentrations of gases may be modified by the compression of the pump.

The turbo pump is designed to pump the following residual gases normally used in high vacuum systems:

- Air
- Carbon monoxide
- Neon
- Ethane
- Methane
- Nitrogen
- Krypton
- Argon
- Propane
- Carbon dioxide
- Helium
- Hydrogen
- Butane

The pump can be used to pump oxygen and water vapour, subject to the following conditions:

- Oxygen - When the pump is purged by an inert gas, oxygen can be pumped at concentrations above 20% by volume. Refer to the nEXT85 instruction manual (B8G0-00-880) for purge gas specification. However, if the pump is not purged, the oxygen concentration must be less than 20% by volume.
- Water vapour - Ensure that vapour does not condense inside the pump.

To pump a gas not in the list above, contact the supplier for advice. Failure to contact the supplier may invalidate the warranty on the pump. The pump is not suitable for pumping aggressive or corrosive gases.

Venting gas specification and vent control data

Although the pump may be vented to atmosphere, high relative humidity of the air may greatly increase the subsequent pump down time. To reduce pump down times the pump should be vented with dry, clean gases.

Refer to the nEXT85 turbo pump manual (B8G0-00-880) for the vent valve connection. Refer to [Vent valve screen](#) on page 20 for configuring the venting options.

Table 18 Vent gas specification and vent control

Vent gas specification and control	Reference data
Vent gas	Dry air, nitrogen, argon or other inert gases
Maximum dew point at atmospheric pressure	-22 °C
Maximum size of particulates	1 µm

Vent gas specification and control	Reference data
Maximum concentration of oil	0.1 parts per million
Recommended time for rotational speed to reach 50%	> 15 seconds
Maximum allowed rate of pressure rise	Refer to
Maximum allowable vent gas supply pressure	1 bar (gauge); 14.5 psig, 2×10^5 Pa

Figure 13 Max allowed rate of pressure rise during venting: pressure against time (pump initially at full speed)

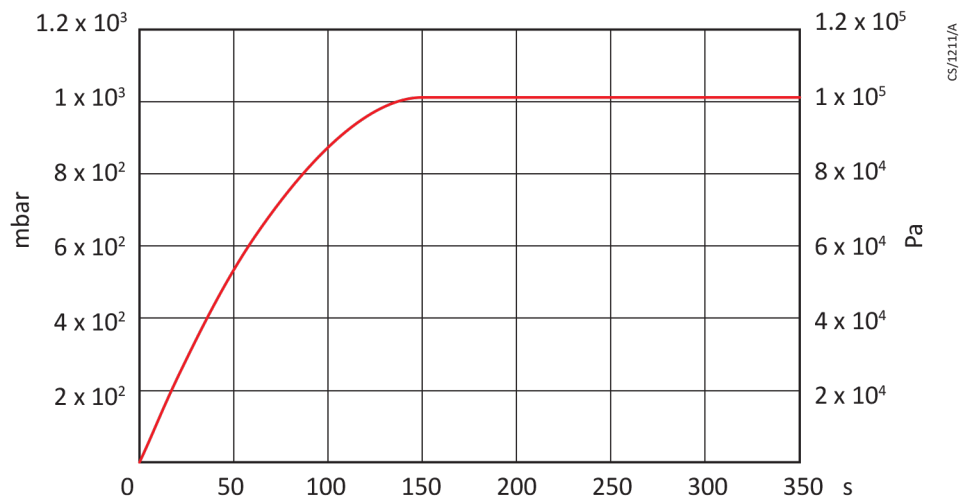

Materials exposed to gases pumped

The following materials and component types are exposed to the gases pumped:

- aluminium alloys
- stainless steels
- fluoroelastomer and nitrile O-rings
- hydrocarbon lubricant
- felt
- rare earth magnets
- silicon nitride
- carbon fibre reinforced epoxy resin
- fire retardant polypropylene
- polyamide
- PVC

Electrical connections

Table 19 Electrical connections

Parameter	Value
Electrical supply (refer to Figure 1 on page 10, item 10)	
Inlet plug type	IEC60320

Parameter	Value
Integral fuse rating	10 A Type T, 20 mm
Backing pump (refer to Figure 1 on page 10, item 9)	
Outlet socket type	IEC60320
Turbomolecular pump (refer to Figure 1 on page 10, item 5)	
Connector type	15-way sub-miniature 'D' type socket
Power supply	24 V d.c. nominal
Maximum power rating	4 W
Active gauge (refer to Figure 1 on page 10, item 6)	
Connector type	RJ45 8-way
Power supply	24 V d.c. nominal
Maximum power rating	4 W

Figure 14 Pin connections for 15-way sub-miniature 'D' type socket

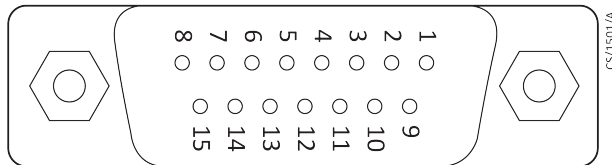
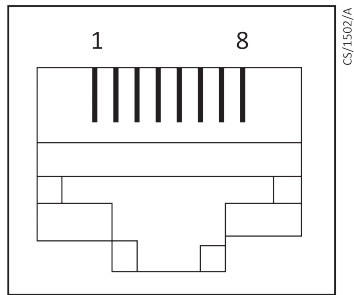

Table 20 Turbo pump connector pin-out

Pin	Function
1	Power supply positive
2	Signal common
3	Start signal output
4	RS232 Tx
5	Serial enable output
6	Power supply positive
7	RS232 Rx
8	Power supply common
9	Speed signal input
10	Screen
11	Power supply positive
12	Screen
13	Power supply common
14	Power supply common
15	Normal signal input

Figure 15 Pin connections for an 8-way RJ45**Table 21** Active gauge connector pin-out

Pin	Function
1	Power supply positive
2	Power supply common
3	Signal input
4	Identification
5	Signal common
6	Control line 1
7	Control line 2
8	Not connected

Electrical data

If the T-Station 85 uses an E2M1.5, the motor start up current is drawn for less than one second, so slow-blow fuses must be used to prevent unnecessary fuse failure when the pump starts. If using the pump at temperatures lower than 12 °C (53.6 °F), the start up current will be drawn for longer; this may cause the motor thermal overload device to open.

Table 22 Electrical data

Supply Voltage 50/60 Hz	Current (A)		Power (W)
	Full load	Start	
XDD1 / nEXT85			
100	3.1	-	310
120	2.6	-	310
200	1.6	-	310
230	1.35	-	310
E2M1.5 / nEXT85			
100	4.7	13.6	470
120	3.92	12.0	470
200	2.2	6.4	430
230	1.9	5.7	430

Figure 16 HS1 Form



Form HS1

Return of Edwards Equipment - Procedure

INTRODUCTION

Before returning your equipment, you must warn Edwards if substances you used (and produced) in the equipment can be hazardous. This information is fundamental to the safety of our Service Centre employees and will determine the procedures employed to service your equipment.

Complete the Declaration (HS2) and send it to Edwards before you dispatch the equipment. It is important to note that this declaration is for Edwards internal use only, and has no relationship to local, national or international transportation safety or environmental requirements. As the person offering the equipment for shipment, it is your responsibility to ensure compliance with applicable laws.

GUIDELINES

- Equipment is 'uncontaminated' if it has not been used, or if it has only been used with substances that are not hazardous. Your equipment is 'contaminated' if it has been used with any substances classified as hazardous under the UN Globally Harmonised System on the classification and labelling of chemicals (GHS), EU Regulation No 1272/2008 on classification, labelling and packaging (CLP) or US Occupational Safety and Health regulations (29CFR1910.1200, Hazard Communication).
- If your equipment has been used with radioactive substances, biological or infectious agents, mercury, polychlorinated biphenyls (PCB's), dioxins or sodium azide, you must decontaminate it before you return it to Edwards. You must send independent proof of decontamination (for example a certificate of analysis) to Edwards with the Declaration (HS2). Phone Edwards for advice.
- If your equipment is contaminated, you must either:
 - Remove all traces of contamination (to the satisfaction of laws governing the transportation of dangerous/hazardous substances).
 - Or, properly classify the hazard, mark, manifest and ship the equipment in accordance with applicable laws governing the shipment of hazardous materials.

Note: Some contaminated equipment may not be suitable for airfreight.

PROCEDURE

1. Contact Edwards and obtain a Return Authorisation Number* for your equipment.
2. Complete the Return of Edwards Equipment - Declaration (HS2).
3. If the equipment is contaminated, you must contact your transporter to ensure that you properly classify the hazard, mark, manifest and ship the equipment, in accordance with applicable laws governing the shipment of contaminated/hazardous materials. As the person offering the equipment for shipment, it is your responsibility to ensure compliance with applicable law. **Note: Equipment contaminated with some hazardous materials, such as semiconductor by-products, may not be suitable for airfreight - contact your transporter for advice.**
4. Remove all traces of hazardous gases: pass an inert gas through the equipment and any accessories that will be returned to Edwards. Where possible, drain all fluids and lubricants from the equipment and its accessories.
5. Seal up all of the equipment's inlets and outlets (including those where accessories were attached) with blanking flanges or, for uncontaminated product, with heavy gauge tape.
6. Seal equipment in a thick polythene/polyethylene bag or sheet.
7. If the equipment is large, strap the equipment and its accessories to a wooden pallet. If the equipment is too small to be strapped to a pallet, pack it in a suitable strong box.
8. E-mail via scan, fax or post a copy of the original with signature of the Declaration (HS2) to Edwards. The Declaration must arrive before the equipment.
9. Give a copy of the Declaration (HS2) to the transporter. You must tell your transporter if the equipment is contaminated.
10. Seal the original Declaration in a suitable envelope: attach the envelope securely to the outside of the equipment package, in a clear weatherproof bag.
WRITE YOUR RETURN AUTHORISATION NUMBER* CLEARLY ON THE OUTSIDE OF THE ENVELOPE OR ON THE OUTSIDE OF THE EQUIPMENT PACKAGE.

* not applicable in Japan

Figure 17 HS2 Form



Form HS2

Return of Edwards Equipment - Declaration

Return Authorisation Number: _____

- You must:
- Know about **all** of the substances which have been used and produced in the equipment before you complete this Declaration
 - Read the Return of Edwards Equipment - Procedure (HS1) before you complete this Declaration
 - Contact Edwards to obtain a Return Authorisation Number and to obtain advice if you have any questions
 - Send this form to Edwards before you return your equipment as per the procedure in HS1

SECTION 1: EQUIPMENT

Manufacturer's Product Name _____ Manufacturer's Part Number _____ Manufacturer's Serial Number _____ Has the equipment been used, tested or operated? YES, Used or operated <input type="checkbox"/> Go to Section 2 YES, Tested, but not connected to any process or production equipment, and only exposed to Nitrogen, Helium or Air <input type="checkbox"/> Go to Section 4 NO <input type="checkbox"/> Go to Section 4	IF APPLICABLE: Tool Identification Number _____ Tool Manufacturer/OEM _____ Tool Model _____ Process _____ Installed Date _____ De-installed Date _____ Part Number of Replacement Equipment _____ Serial Number of Replacement Equipment _____ Pump datalog attached? YES <input type="checkbox"/> NO <input type="checkbox"/> (Edwards Internal Use Only)
---	---

SECTION 2: SUBSTANCES IN CONTACT WITH THE EQUIPMENT

Are any substances used or produced in the equipment: <ul style="list-style-type: none"> • Radioactive, biological or infectious agents, mercury, poly chlorinated biphenyls (PCBs), dioxins or sodium azide? (if YES, see Note 1) YES <input type="checkbox"/> NO <input type="checkbox"/> • Hazardous to human health and safety? YES <input type="checkbox"/> NO <input type="checkbox"/> 	Note 1: Edwards will not accept delivery of any equipment that is contaminated with radioactive substances, biological/infectious agents, mercury, PCB's, dioxins or sodium azide, unless you: <ul style="list-style-type: none"> • Decontaminate the equipment • Provide proof of decontamination YOU MUST CONTACT EDWARDS FOR ADVICE BEFORE YOU RETURN SUCH EQUIPMENT
--	---

SECTION 3: LIST OF SUBSTANCES IN CONTACT WITH THE EQUIPMENT

Substance name	Chemical Symbol	Precautions required (for example, use protective gloves, etc.)	Action required after a spill, leak or exposure

SECTION 4: RETURN INFORMATION

Reason for return and symptoms of malfunction: _____

For how many hours has the product run? _____ Do you wish to purchase a full Failure Analysis report? YES NO

If you have a warranty claim:

- who did you buy the equipment from? _____
- give the supplier's invoice number _____

SECTION 5: DECLARATION

Print your name: _____ Print your job title: _____

Print your organisation: _____

Print your address: _____

Telephone number: _____ Date of equipment delivery: _____

I have made reasonable enquiry and I have supplied accurate information in this Declaration. I have not withheld any information, and I have followed the Return of Edwards Equipment - Procedure (HS1).

Signed: _____ Date: _____

Note: Please print out this form, sign it and return the signed form as hard copy.

P900-71-000 Issue N

