

Instruction Manual

GXS Dry Pumping Systems



FOR SALES AND SERVICE PLEASE CALL:

PTB SALES T :: 626.334.0500
service@ptbsales.com
www.ptbsales.com

DATE SERVICED: _____

VIEW OUR INVENTORY



WWW.EDWARDSVACUUM.COM

GXS Industrial Pump Numbering

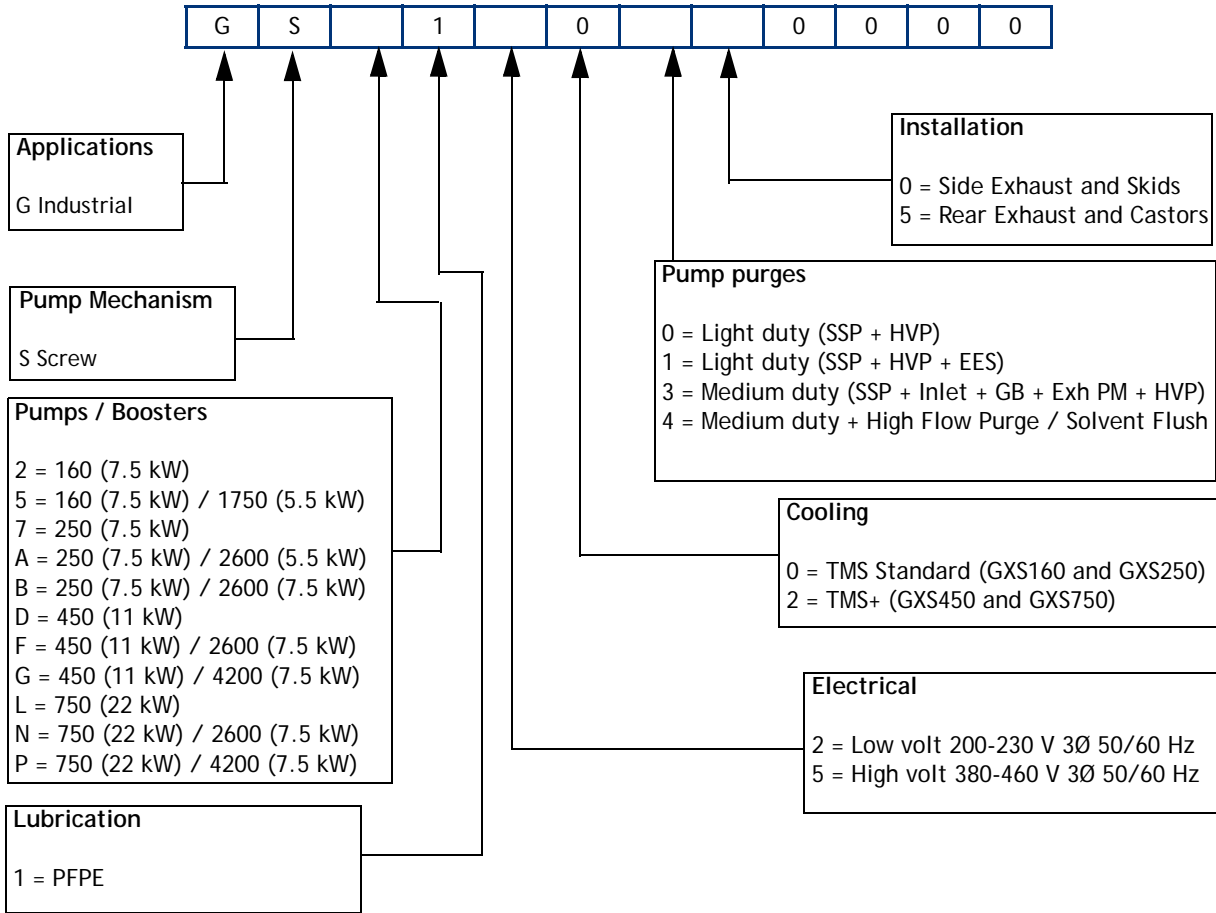

SSP = Shaft seal purge, Inlet = Inlet purge, GB = Gas ballast, Exh PM = Exhaust pressure monitor & purge, HVP = High Vacuum Gearbox Purge, EES = External Evacuation System



Declaration of Conformity

We, Edwards Limited,
Crawley Business Quarter,
Manor Royal,
Crawley,
West Sussex, RH10 9LW, UK

declare under our sole responsibility, as manufacturer and person within the EU authorised to assemble the technical file, that the product(s)

	<i>Low Volt Systems (200-230V)</i>	<i>High Volt Systems (380-460V)</i>
GXS 160	GS2120yz0000	GS2150yz0000
GXS 160/1750	GS5120yz0000	GS5150yz0000
GXS 250	GS7120yz0000	GS7150yz0000
GXS 250/2600 (5.5kW MB)	GSA120yz0000	GSA150yz0000
GXS 250/2600 (7.5kW MB)	GSB120yz0000	GSB150yz0000
GXS 450	GSD12xyz0000	GSD15xyz0000
GXS 450/2600	GDF12xyz0000	GSF15xyz0000
GXS 450/4200	GSG12xyz0000	GSG15xyz0000
GXS 750	GSL12xyz0000	GSL15xyz0000
GXS 750/2600	GSN12xyz0000	GSN15xyz0000
GXS 750/4200	GSP12xyz0000	GSP15xyz0000

Where x = 0 or 2 depending on TMS system
Where y = 0, 1, 3 or 4 depending on gas module type
Where z = 0, 1, 4 or 5 depending on installation options

to which this declaration relates is in conformity with the following standard(s) or other normative document(s)

EN1012-2:1996+A1: 2009	Compressors and Vacuum Pumps. Safety Requirements. Part 2 - Vacuum Pumps.
EN61010-1: 2010	Safety Requirements for Electrical Equipment for Measurement, Control and Laboratory Use. Part 1 - General Requirements.
EN 61326-1: 2013	Electrical equipment for measurement, control and laboratory Use - EMC requirements. (Industrial Location Immunity - Class A Emissions)
EN50581: 2012	Technical Documentation for the Assessment of Electrical and Electronic Products with respect to the Restriction of Hazardous Substances
CAN/CSA-C22.2 No. 61010-1-12	Safety requirements for electrical equipment for measurement, Control and laboratory use - Part 1: General requirements
UL61010-1, 2 nd Edition	Safety requirements for electrical equipment for measurement, Control and laboratory use - Part 1: General requirements

and fulfils all the relevant provisions of

2006/42/EC	Machinery Directive
2014/35/EU	Low Voltage Directive
2014/30/EU	Electromagnetic Compatibility (EMC) Directive
2011/65/EU	Restriction of Certain Hazardous Substances (RoHS) Directive

Note: This declaration covers all product serial numbers from the date this Declaration was signed onwards.



Malcolm Gray, Technical Manager - Dry Pumps

14.05.2015, Burgess Hill

Date and Place

This product has been manufactured under a quality management system certified to ISO9001:2008

Product Information for China





The Chinese regulatory requirement on the Control of Pollution Caused by Electronic Information Products No. 39 (also known as 'China RoHS') mandates that manufacturers of certain categories of electronic products sold in China after 1st March 2007 -

- Mark the product and packaging
- Define the Product's Environment Protection Use Period (EPUP)
- Provide a Materials Content Declaration.

Product Labels

Product	Product Label	Meaning
All GXS models		Indicates toxic or hazardous substance contained in at least one of the homogeneous materials used for this part is above the limit requirement in SJ/T11363-2006. Environmental Protection Use Period is 20 years.

Packaging Information

Pallet	Overshipper	Protection Pieces	Support Braces
			
Recyclable Natural Wood	Recyclable Cardboard	Recyclable Polypropylene	Recyclable Mild Steel

Environmental Protection Use Period (EPUP)

This is the period in years during which the toxic or hazardous substances or elements contained in this product will not leak or mutate under normal operating conditions so that the use of such electronic information products will not result in any severe environmental pollution, any bodily injury or damage to any assets.

The Environmental Protection Use Period is 20 years for this product.

For the purposes of EPUP, normal operating conditions are considered to be use in accordance with the product's instruction manual.

Materials Content Declaration for GXS

Part name	Toxic or Hazardous Substances and Elements					
	Lead (Pb)	Mercury (Hg)	Cadmium (Cd)	Hexavalent Chromium (Cr VI)	Polybrominated biphenyls (PBB)	Polybrominated diphenyl ethers (PBDE)
Motor (mechanical booster)	0	0	0	0	0	0
Motor (pump)	0	0	0	0	0	0
Pump & booster	0	0	0	0	0	0
Electronics and Controls	0	0	X	0	0	0
Cooling system	0	0	0	0	0	0
Purge system	0	0	0	0	0	0

O: Indicates that this toxic or hazardous substance contained in all of the homogeneous materials for this part is below the limit requirement in SJ/T11363-2006.
X: Indicates that this toxic or hazardous substance contained in at least one of the homogeneous materials used for this part is above the limit requirement in SJ/T11363-2006.

Contents

Section	Page
1	Introduction 1
1.1	Scope and definitions 1
1.2	Applications 2
1.3	Description 2
1.4	Priority of control 3
1.5	Active utility control / standby 3
2	Technical data 7
2.1	General technical data 7
2.2	Performance data 8
2.3	Loading data 8
2.4	Purge data 10
2.5	Electrical data 11
2.6	Cooling-water data 14
2.7	DP clean high flow purge / solvent flush option 17
2.8	External evacuation system 17
3	Installation 19
3.1	Locate the dry pumping system 20
3.1.1	Dry pumping systems with optional castors 20
3.1.2	Levelling the pump 21
3.1.3	Securing the pump 21
3.2	Lubrication 21
3.3	Connect the dry pumping system to the vacuum / exhaust system 21
3.4	Connect the purge gas supply 24
3.4.1	Flammable / pyrophoric materials 24
3.4.2	Gas purges 25
3.5	Leak test the dry pumping system 25
3.6	Electrical supply 27
3.6.1	Mains supply cable connection 28
3.6.2	Customer Connection Kit, Combination Low Volts GXS750 31
3.7	Connect an additional RF earth (ground) (optional) 33
3.8	Connect to your emergency stop circuit 34
3.9	Connect and set up cooling water 34
3.10	Accessories 36
3.11	Commission the dry pumping system 36
3.12	Install additional safety equipment 37
3.13	Purge gas set up 37
3.14	High flow purge and solvent flush set up 38
3.15	Connecting the GXS dry pumping system for serial communications 40
3.15.1	Serial port connection 40
3.15.2	Ethernet connection 40
4	Operation 41
4.1	Start up 41
4.1.1	MCM MicroTIM operation 42
4.1.2	PDT operation 42
4.1.3	Front panel control operation 42
4.1.4	Start, warm-up and on-process sequences 42
4.2	Status indicators 43
4.2.1	Determining pump status 44

4.3	Green Mode/Standby mode	44
4.4	Manual shut down	45
4.4.1	MicroTIM operation	46
4.4.2	PDT operation	46
4.4.3	Front panel control operation	46
4.5	Automatic shut down	46
4.6	Unplanned shut down and alarms	47
4.7	Emergency stop	47
4.8	Restart the pump after an emergency stop or automatic shut down	48
4.9	Dry pump clean	48
4.9.1	High flow purge	48
4.9.2	Solvent flush	49
4.10	Pump speed control and PID	50
5	Maintenance	51
5.1	Safety and maintenance frequency	51
5.2	Relocate the dry pumping system for maintenance	52
5.3	Draining the cooling water	53
5.4	General maintenance	54
5.4.1	Checking the oil levels and refilling	54
5.4.2	Inspect the connections, pipelines, cables and fittings	56
5.5	Overhaul	56
6	Transportation, storage and disposal	57
6.1	Transportation	57
6.2	Storage	57
6.3	Disposal	57
7	Service, spares and accessories	59
7.1	Introduction	59
7.2	Service	59
7.3	Ordering accessories	60
7.4	Spares	60
Appendix A1	Installation drawings	61
A1.1	GXS160	61
A1.2	GXS160/1750	65
A1.3	GXS250	69
A1.4	GXS250/2600	73
A1.5	GXS450	77
A1.6	GXS450/2600	81
A1.7	GXS450/4200	85
A1.8	GXS750	89
A1.9	GXS750/2600	93
A1.10	GXS750/4200	97
Appendix A2	Pump display terminal	101
A2.1	LEDs	101
A2.2	Pump start / stop and control	102
A2.3	Event / warning / alarm display and acknowledgement	102
A2.4	Menus	103
A2.4.1	Normal menu	103
A2.4.2	Status menu	103
A2.4.3	Setup menu	104
A2.4.4	Commands menu	105
A2.4.5	Set sequences menu	105
A2.4.6	Display Inverter Fault History (DP Inv Fault Hist) menu	111

A2.4.7	Software version display menu	111
A2.4.8	Display serial number	111
A2.4.9	Fit accessory menu	112
A2.4.10	IP configuration menu	113
A2.4.11	Display menu	113
A2.4.12	Set clock	114
A2.5	How to set up the PDT display	115
A2.5.1	Setting the status screen to automatically scroll	115
A2.5.2	Change the normal menu display	115
A2.6	How to configure the pump warm-up options	116
A2.6.1	Lowering the warm-up temperature	116
A2.6.2	Disabling warm-up cycle	116
A2.6.3	Increasing the warm-up temperature	117
A2.6.4	Stop the pump going on-process when it is warm	117
A2.6.5	Stop the pump automatically warming up when in Green Mode / standby mode	117
A2.6.6	Turn inlet purge on during warm-up	117
A2.6.7	Allow a pump to go on-process with a warning	117
A2.6.8	Warm soft start	117
A2.7	How to configure the booster pump behaviour	117
A2.7.1	Setting the booster to manual operation	118
A2.7.2	Changing the booster time delay	118
A2.7.3	Setting the booster to start when the inlet isolation valve is open	118
A2.8	How to configure pump behaviour	119
A2.8.1	Smart stop	119
A2.8.2	How to configure ramped speed increase	120
A2.9	How to set up DP clean	121
A2.9.1	Changing the dry pump speed during the clean operation	123
A2.9.2	Changing the clean cycle time	124
A2.9.3	Automatically initiating a clean cycle when the pump goes off-process	124
A2.9.4	Turn inlet purge on during the clean cycle	124
A2.9.5	Have inlet purge cycle after clean cycle	124
A2.9.6	Allow on process	124
A2.9.7	Auto on shutdown	124
A2.10	How to control pump speed	124
A2.10.1	Normal speed	125
A2.10.2	External voltage	126
A2.10.3	SIM protocol	126
A2.10.4	Second speed control	126
A2.10.5	Profibus interface	126
A2.11	How to use PID pressure control	127
A2.11.1	Fit and configure the pressure sensor	128
A2.11.2	Using a different gauge	129
A2.11.3	Set pump into Green Mode mode	129
A2.11.4	Enable PID	129
A2.11.5	Set the PID target pressure set point	130
A2.11.6	Test the PID control	130
A2.11.7	Auto tune the PID	130
A2.11.8	Manually tuning the PID	130
A2.11.9	Turning PID on and off when on-process	130
A2.12	How to set up the Ethernet port	131
A2.12.1	Using SIM protocol through Ethernet	133
A2.12.2	Web server pages	135
A2.13	How to use SIM protocol with a serial port	138
A2.14	How to set up the MCM MicroTIM using the PDT	139
A2.14.1	Configuring the channel 2 input	140
A2.14.2	Configuring the channel 4 output	141
A2.15	How to run the booster independently from the dry pump	141
A2.15.1	Run the booster manually using the PDT	141
A2.15.2	Run the booster using SIM and Profibus	141
A2.15.3	Run the booster using the MCM MicroTIM	141
Appendix A3 Troubleshooting		143

A3.1	PDT events	143
A3.1.1	LED event indicators	143
A3.1.2	PDT event messages	143
A3.2	Warnings	144
A3.2.1	LED warning indicators	144
A3.2.2	PDT warnings	144
A3.3	Alarms	146
A3.3.1	LED alarm indicators	146
A3.3.2	PDT alarms	147
A3.4	Inverter warnings and alarms	148
A3.5	Other problems	152
A3.5.1	Pump controller communications	152

For return of equipment, complete the HS Forms at the end of this manual.

Illustrations

Figure	Page	
1	The front panel controls	4
2	Front view of pumping system with side exhaust and skids fitted	4
3	The controls/connectors on the rear of the pump (system with rear exhaust and castors/levelling feet fitted) 5	5
4	Levelling foot loads	9
5	Connecting the pump inlet	23
6	Interspool connections on pump/booster combination systems	25
7	The Harting Han® K 4/4 cable-mounted connector	30
8	The Harting Han® 100A axial screw module cable-mounted connector	31
9	Customer connection kit - combination low volts GXS750	32
10	Electrical connector locking mechanism for GXS160, GXS250 & GXS450 systems	33
11	Electrical connector locking mechanism for GXS750 systems	33
12	Remove the plastic plugs from the water fittings	35
13	DP clean assembly for pump only systems	39
14	Location of oil sight glass and fill plug on end cover	55
15	Location of oil sight glass and fill plug on gearbox	56
A1	GXS160 installation drawing (Sheet 1)	61
A2	GXS160 installation drawing (Sheet 2)	62
A3	GXS160 installation drawing (Sheet 3)	63
A4	GXS160 installation drawing (Sheet 4)	64
A5	GXS160/1750 installation drawing (Sheet 1)	65
A6	GXS160/1750 installation drawing (Sheet 2)	66
A7	GXS160/1750 installation drawing (Sheet 3)	67
A8	GXS160/1750 installation drawing (Sheet 4)	68
A9	GXS250 installation drawing (Sheet 1)	69
A10	GXS250 installation drawing (Sheet 2)	70
A11	GXS250 installation drawing (Sheet 3)	71
A12	GXS250 installation drawing (Sheet 4)	72
A13	GXS250/2600 installation drawing (Sheet 1)	73
A14	GXS250/2600 installation drawing (Sheet 2)	74
A15	GXS250/2600 installation drawing (Sheet 3)	75
A16	GXS250/2600 installation drawing (Sheet 4)	76
A17	GXS450 installation drawing (Sheet 1)	77
A18	GXS450 installation drawing (Sheet 2)	78
A19	GXS450 installation drawing (Sheet 3)	79
A20	GXS450 installation drawing (Sheet 4)	80
A21	GXS450/2600 installation drawing (Sheet 1)	81
A22	GXS450/2600 installation drawing (Sheet 2)	82
A23	GXS450/2600 installation drawing (Sheet 3)	83

A24	GXS450/2600 installation drawing (Sheet 4)	84
A25	GXS450/4200 installation drawing (Sheet 1)	85
A26	GXS450/4200 installation drawing (Sheet 2)	86
A27	GXS450/4200 installation drawing (Sheet 3)	87
A28	GXS450/4200 installation drawing (Sheet 4)	88
A29	GXS750 installation drawing (Sheet 1)	89
A30	GXS750 installation drawing (Sheet 2)	90
A31	GXS750 installation drawing (Sheet 3)	91
A32	GXS750 installation drawing (Sheet 4)	92
A33	GXS750/2600 installation drawing (Sheet 1)	93
A34	GXS750/2600 installation drawing (Sheet 2)	94
A35	GXS750/2600 installation drawing (Sheet 3)	95
A36	GXS750/2600 installation drawing (Sheet 4)	96
A37	GXS750/4200 installation drawing (Sheet 1)	97
A38	GXS750/4200 installation drawing (Sheet 2)	98
A39	GXS750/4200 installation drawing (Sheet 3)	99
A40	GXS750/4200 installation drawing (Sheet 4)	100
A41	Pump display terminal	101
A42	PDT menu items	115
A43	Warm-up PDT menu items	116
A44	Booster PDT menu configuration items	118
A45	Smart stop flow chart	119
A46	Smart stop PDT menu configuration items	120
A47	On-process ramp PDT menu configuration items	121
A48	Dry pump clean flow chart	122
A49	Dry pump clean PDT menu configuration items	123
A50	Speed control menu items	125
A51	Pin numbers on the auxiliary gauge interface	126
A52	The simplified system diagram	127
A53	PID PDT menu items	128
A54	Ethernet menu items	132
A55	Setup menu items	133
A56	Ping to a pump screenshot	133
A57	Connect to screenshot	134
A58	ASCII setup screenshot	134
A59	Overview screenshot	135
A60	Gauges screenshot	136
A61	Parameters screenshot	137
A62	Alerts screenshot	137
A63	Units screenshot	138
A64	ASCII settings screenshot	139
A65	MicroTIM options menu	140
A66	Booster commands menu	141

Tables

Table		Page
1	General technical data	7
2	General technical data	7
3	Performance data	8
4	Loading data	8
5	Purge data	10
6	Gas module types and flows	10
7	Electrical data	11
8	General electrical data	12
9	Electrical connections	13
10	Wire assembly according to VDE 0295	14
11	Water cooling system data	14

12	Water consumption data (GXS160/250/1750/2600)	15
15	Water consumption data (GXS750 only)	16
16	Water consumption data (GXS750/2600/4200)	16
17	High flow purge / solvent flush data	17
18	Start, warm-up and on-process sequences	43
19	Status indicator LEDs	43
20	Pump status	44
21	Green Mode/Standby sequence	44
22	Stop sequences	45
23	Alarm actions	46
24	Pump protection sensors	47
25	DP clean sequence	48
26	Accessories	60
27	Spares	60
A1	PDT displays	102
A2	PDT displays	102
A3	Normal menu	103
A4	Typical display	103
A5	PDT setup menu structure	104
A6	Commands menu	105
A7	Gas valves menu	105
A8	Set sequences menu	105
A9	Warm up options menu	106
A10	Booster pump start options menu	107
A11	MicroTIM options menu	107
A12	DP clean options menu	108
A13	On-process ramp options menu	108
A14	PID options menu	109
A15	PID parameters options menu	109
A16	Smart stop options menu	110
A17	Speed control options menu	110
A18	Fault history menu	111
A19	Software display menu	111
A20	Accessory menu	112
A21	Configuration menu	113
A22	Display menu	113
A23	Units	114
A24	Selection menu	114
A25	Speed control sources	124
A26	SIM protocol	133
A27	COM port settings	138
A28	Events	143
A29	Warnings	144
A30	Alarms	147
A31	Hexadecimal to digital conversion	149
A32	Inverter alarm codes	149
A33	Inverter warning codes	151

Associated publications

Publication title	Publication Number
Vacuum pump and vacuum systems - safety manual	P400-40-100
Pumping flammable gases - applications note	P411-00-090
SIM protocol - instruction manual	P411-00-200
MicroTIM - instruction manual	D373-60-880
GXS 100 centres customer parts manual	M588-40-845
GXS 150 centres customer parts manual	M598-40-845

Trademark credits

Han® is a registered trademark of Harting Electric GmbH
EtherCon® is a registered trademark of Neutrik® AG
Fomblin® is a registered trademark of Solvay Solexis SpA
Krytox® is a registered trademark of DuPont (E.I. du Pont de Nemours and Company)
Loctite® is a registered trademark of Henkel Corporation
Natural Blue® is a registered trademark of Henkel Corporation

This page has been intentionally left blank.

1 Introduction

1.1 Scope and definitions

This manual provides installation, operation and maintenance instructions for the Edwards GXS dry pumping systems. The dry pumping system must be used as specified in this manual otherwise the protection provided by the equipment may be impaired.

Read this manual before installing and operating the dry pumping system. Important safety information is highlighted as WARNING and CAUTION instructions; these instructions must be obeyed. The use of WARNINGS and CAUTIONS is defined below.



WARNING

Warnings are given where failure to observe the instruction could result in injury or death to people.

CAUTION

Cautions are given where failure to observe the instruction could result in damage to the equipment, associated equipment and/or process.

The units throughout this manual conform to the SI international system of units of measurement.

The following warning labels are on the pump:



Warning - Refer to accompanying documentation.



Warning - Maximum angle between paired slings.



Warning - Risk of electric shock.



Warning - Heavy object.



Warning - Hot surfaces.



Protective Earth (ground).



Warning - Moving parts present.



Warning - Use protective equipment.



RF Earth (ground).

The following warnings only appear in this manual:



Warning - Risk of explosion.



Warning - Pressurised.

Safety data sheets for chemicals supplied by Edwards can be obtained by contacting Edwards or on www.edwardsvacuum.com.

1.2 Applications

GXS dry pumping systems are suitable for a wide range of industrial applications. Edwards has a dedicated team of applications engineers who can help to determine the best dry pumping system for an application.

Warranties may be invalidated if the dry pumping system is used on an unsuitable application. If in doubt, contact Edwards.

1.3 Description

The GXS dry pumping systems range has been developed to meet the demanding requirements for process pumping solutions in industrial applications. The range sets new standards for harsh process capability, reliability and reduced cost of ownership in low footprint packages.

There are various different ways to control the dry pumping system and monitor status. The user can manually press controls on the front panel and monitor LEDs on the front and rear of the dry pumping system. The Edwards Pump Display Terminal (PDT) gives further functionality for set up and status monitoring. Alternatively the dry pumping system can be controlled using a distributed control system by connecting to the parallel interface by the MCM MicroTIM. There are also several serial interface options, including Ethernet connection.

A high flow purge / solvent flush kit is available as an option to clean the dry pumping system on applications where large quantities of dust and sticky deposits are encountered. The cleaning process is run while the dry pumping system is in Green Mode/Standby mode and is carried out without the need to remove the pump enclosure. A PDT is required to initiate the cleaning process, it controls a set sequence called DP Clean.

1.4 Priority of control

The dry pumping system can be controlled by a number of modules: the front control panel (refer to [Figure 1](#)), a Pump Display Terminal (PDT) or by the customer's system through the MCM MicroTIM or one of the serial interfaces. Only one of these can have control of the dry pumping system at any one time. That is, once one of these has control of the dry pumping system, control requests from the others are denied. Control must be released by one module before control can be taken by a different module.

There are LEDs to indicate control:

- The LED on the front control panel illuminates when control is taken by the front panel, refer to [Figure 1](#), item 6.
- The LED on the rear of the pump illuminates when control is taken by the MicroTIM, refer to [Figure 3](#), item 9.
- The local control LED on the PDT illuminates when control is taken by that particular PDT, refer to [Appendix A2](#).

The PDT display also indicates which system is in control.

1.5 Active utility control / standby

The Active Utility Control (Green Mode) function may reduce speed, power and purge gas consumption of the dry pumping system while on standby. The dry pumping system can be put into Green Mode / standby mode using the front control panel, the PDT or through the MCM MicroTIM. Refer to [Section 4.3](#) for more information.

Figure 1 - The front panel controls

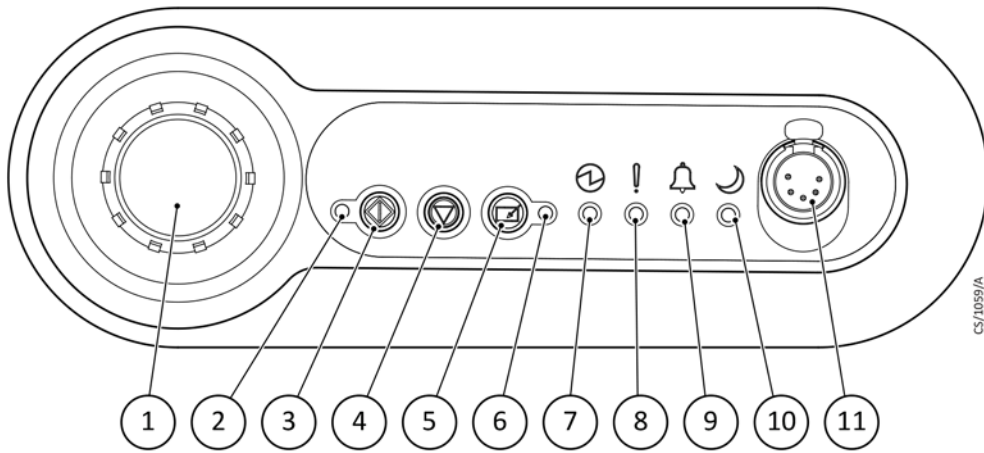

- | | |
|------------------------------|---|
| 1. EMS button | 7. Power PED (green) |
| 2. Running LED (green) | 8. Warning LED (yellow) |
| 3. Start button | 9. Alarm LED (red) |
| 4. Stop button | 10. Green Mode LED (green) |
| 5. Local control button | 11. PDT (Pump Display Terminal) connections |
| 6. Local control LED (green) | |

Figure 2 - Front view of pumping system with side exhaust and skids fitted

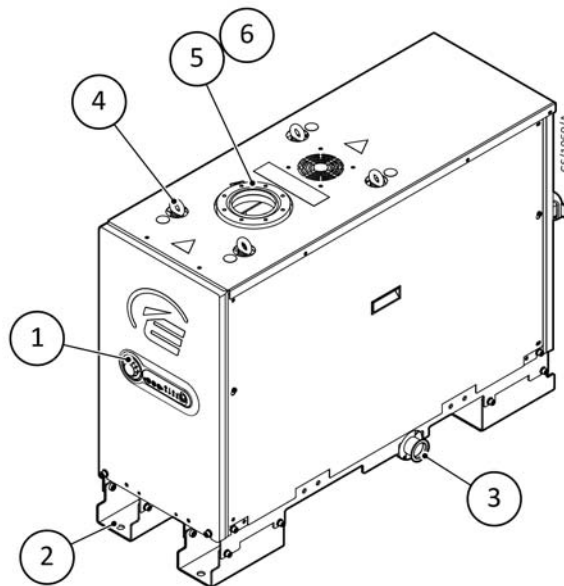

1. Front panel controls
2. Floor mounting plate (4 off)
3. Exhaust gas outlet connection
4. Lifting eyebolt (4 off)
5. Pumped gas inlet connection
6. RF Earth (ground) cable

Figure 3 - The controls/connectors on the rear of the pump (system with rear exhaust and castors/levelling feet fitted)

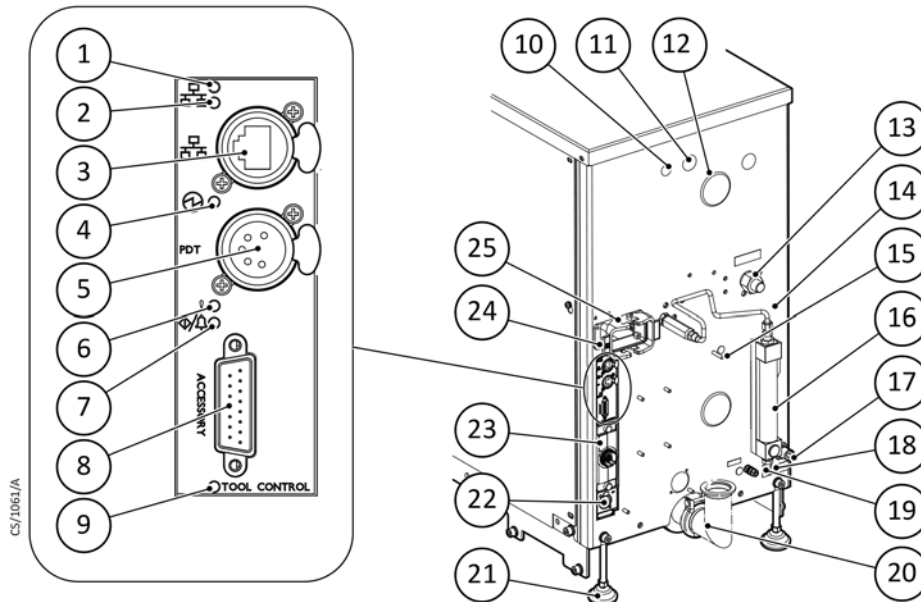

- | | |
|--|--|
| 1. Ethernet LAN LED (green) | 13. Cooling water in |
| 2. Ethernet link LED (yellow) | 14. Auxiliary gauge or pressure input connection (if fitted) |
| 3. Ethernet connection | 15. Protective Earth (ground) stud |
| 4. Power LED (green) | 16. Purge gas rotameter |
| 5. System interface (PDT & serial SIM) | 17. Cooling water out |
| 6. Warning LED (yellow) | 18. Purge gas connection |
| 7. Running and alarm LEDs (2 colours, either green or red) | 19. RF Earth (ground) stud |
| 8. Accessory interface | 20. Exhaust gas outlet connection |
| 9. MicroTIM in control LED (green) | 21. Levelling foot (if fitted) |
| 10. Pneumatic valve inlet connection (if fitted) | 22. EMS interface |
| 11. DP clean solvent flush fluid connection (if fitted) | 23. MicroTIM connection (if fitted) |
| 12. High flow purge air filter (if fitted) | 24. Electrical supply connector |
| | 25. Electrical connector locking mechanism |

This page has been intentionally left blank.

2 Technical data

2.1 General technical data

Table 1 - General technical data

Pump	Characteristics								
	Body dimensions length x width x height*	Mass (excluding packaging)	Noise level (at ultimate with a piped exhaust)	Typical vibration level at inlet	Initial force to push the pump [†]	Sustained force to push the pump [†]	Pump inlet flange (bolted)	Exhaust gas outlet	Lubricant volume
Units	mm	kg	dB(A)	mm/s	kg force	kg force			litre
GXS160	1092 x 390 x 568	305	< 64	< 1.5	< 20	< 10	ISO63	NW40	0.7
GXS160/ 1750	1092 x 390 x 830	475	< 64	< 1.5	< 20	< 10	ISO100	NW40	1.4
GXS250	1092 x 390 x 568	305	< 64	< 1.5	< 20	< 10	ISO63	NW40	0.7
GXS250/ 2600	1092 x 390 x 830	515	< 64	< 1.5	< 20	< 10	ISO160	NW40	1.4
GXS450	1186 x 517 x 717	546	< 64	< 1.5	10	5	ISO100	NW50	1.8
GXS450/ 2600	1186 x 517 x 1031	760	< 64	< 1.5	16	6	ISO160	NW50	2.4
GXS450/ 4200	1186 x 517 x 1031	818	< 64	< 1.5	22	< 10	ISO160	NW50	3.3
GXS750	1622 x 517 x 717	679	< 70	< 1.5	15	5	ISO100	NW50‡	2.8
GXS750/ 2600	1622 x 517 x 1031	918	< 70	< 1.5	22	< 10	ISO160	NW50‡	3.5
GXS750/ 4200	1622 x 517 x 1031	976	< 70	< 1.5	22	< 10	ISO160	NW50‡	4.3

* Refer to installation drawings in Appendix A1.

† For dry pumping systems fitted with optional castors; measured in laboratory on level concrete surface.

‡ Refer to Section 3.3 for information relating to exhaust size and length for GXS750 dry pumping systems.

Table 2 - General technical data

Item	Description	Rating	Units
Operating conditions	Intended use	Indoor	
	Ambient temperature range:		
	Operating	5 to 40	°C
	Storage	- 45 to 55	°C
	Maximum relative humidity:	80% for temperatures up to 31 °C decreasing linearly to 50% relative humidity at 40 °C	
Maximum operating altitude	2000		m
Pollution degree	2 (IEC 61010)		

Table 2 - General technical data (continued)

Item	Description	Rating	Units
Materials in contact with process gas	Pump, shaft and rotors	Cast SG iron, steel	
	Seals	PTFE and fluoroelastomer	
	Gas system	Stainless steel, aluminium, brass, PTFE and fluoroelastomer	
Degree of protection	Hazardous electrical sub system	IP21D (IEC60529)	
Lubrication	Oil type	PFPE Drynert 25/6 (recommended) Fomblin [®] 25/6 (alternative) Krytox [®] 1525 (alternative)	

2.2 Performance data

Table 3 - Performance data

Pump	Characteristics		
	Typical peak pumping speed	Ultimate (shaft seal purge only)	Maximum continuous inlet pressure
Units	m ³ /h	mbar	mbar
GXS 160	160	< 1 x 10 ⁻²	1000
GXS 160/1750	1160	< 1 x 10 ⁻³	1000
GXS 250	250	< 1 x 10 ⁻²	1000
GXS 250/2600	1900	< 1 x 10 ⁻³	1000
GXS450	450	< 1 x 10 ⁻²	1000*
GXS450/2600	2200	< 1 x 10 ⁻³	1000*
GXS450/4200	3026	< 1 x 10 ⁻³	1000*
GXS750	740	< 1 x 10 ⁻²	1000*
GXS750/2600	2300	< 1 x 10 ⁻³	1000*
GXS750/4200	3450	< 1 x 10 ⁻³	1000*

* Speed may be limited.

2.3 Loading data

Refer to installation drawings in [Appendix A1](#) for centre of gravity positions for dry pumping systems. The loading data in [Table 4](#) is for dry pumping systems with optional levelling feet and castors. Refer to [Figure 4](#) for foot positions.

Table 4 - Loading data

Pump	Load at levelling foot position (kg)			
	1	2	3	4
GXS 160	76	76	76	76
GXS 160/1750	127	109	109	127
GXS 250	76	76	76	76
GXS 250/2600	154	103	103	154
GXS450	131	142	142	131

Table 4 - Loading data (continued)

	Load at levelling foot position (kg)			
GXS450/2600	171	209	209	171
GXS450/4200	180	229	229	180
GXS750	160	180	180	160
GXS750/2600	215	244	244	215
GXS750/4200	229	259	259	229

Figure 4 - Levelling foot loads

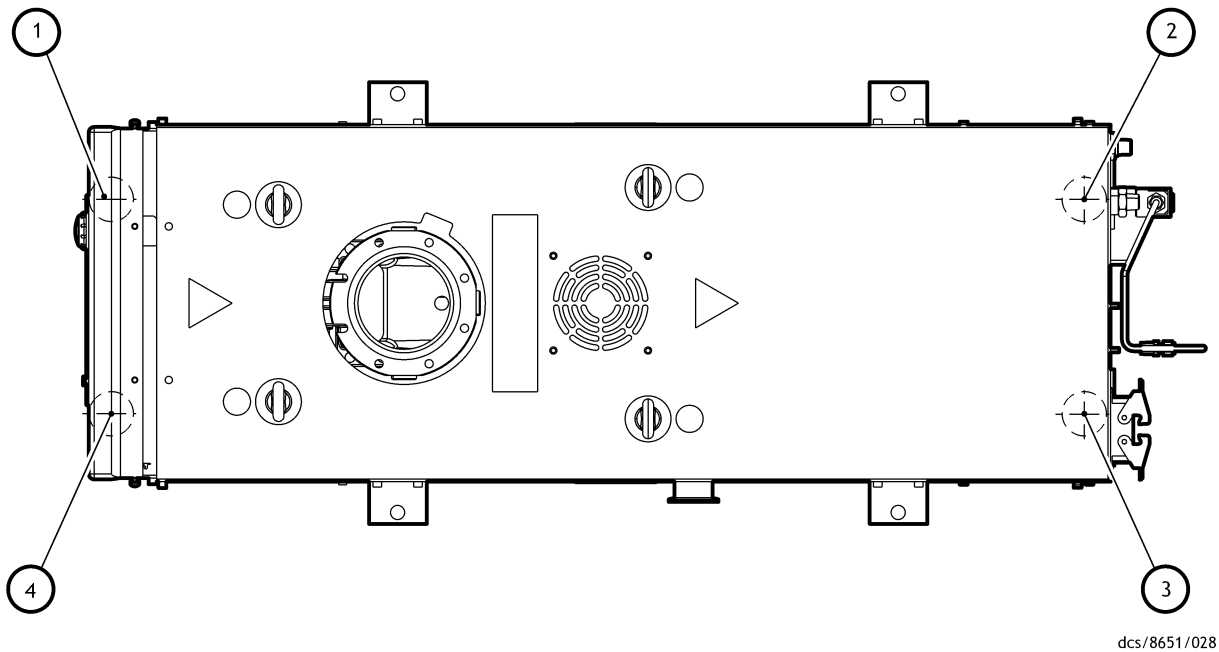

dcs/8651/028

2.4 Purge data

Table 5 - Purge data

Characteristics	Rating	Units
Purge gas supply pressure range	2.5 - 6.9	bar gauge
	36 - 100	psi gauge
Purge gas supply quality	ISO 8573	µm
Purge gas inlet connection	1/4 inch tube fitting	

Table 6 - Gas module types and flows

Gas module type	Description	Cycle	Gas flows (slm)					Total flow
			Shaft seal purge	Inlet purge	Manually-adjusted gas ballast	Additional gas ballast*	Exhaust purge	
Light Duty (All GXS systems) [†]	Shaft seal only	Off	0	n/a	n/a	n/a	n/a	0
		Green Mode	12	n/a	n/a	n/a	n/a	12
		On-process	12	n/a	n/a	n/a	n/a	12
		Shut-down	12	n/a	n/a	n/a	n/a	12
Medium Duty (GXS160 & GXS250 systems) [†]	Electronically-controlled gas ballast purge (with manually adjusted flow) + inlet purge + exhaust purge	Off	0	0	0	n/a	0	0
		Green Mode	12	0	0	n/a	6	18
		On-process	12	0	0-34	n/a	6	18-52
		Shut-down	12	16	0	n/a	6	34
Medium Duty (GXS450 & GXS750 systems) [†]	Gas ballast purge (with manually adjusted flow) + inlet purge + exhaust purge + option of an additional electronically-controlled gas ballast*	Off	0	0	0	0	0	0
		Green Mode	12	0	0-64	0	6	18-82
		On-process	12	0	0-64	0(default) 64(enabled)	6	18-146
		Shut-down	12	26	0-64	0	6	44-108

* By default the dry pumping system is supplied with the additional gas ballast switched off. This additional gas ballast can be enabled in software using the optional PDT.

† GXS dry pumping systems in a standard configuration must run with a seal purge. If the application requires removal of seal purge, consult an Edwards application specialist.

2.5 Electrical data

Table 7 - Electrical data

Characteristics	GXS160	GXS160 /1750	GXS250	GXS250 /2600	GXS450	GXS450 /2600	GXS450 /4200	GXS750	GXS750 /2600	GXS750 /4200	Units
Dry pump motor rating	7.5	7.5	7.5	7.5	11	11	11	22	22	22	kW
Mechanical booster motor rating	-	4.5	-	7.5	-	7.5	7.5	-	7.5	7.5	kW
Current rating (200 - 230 V systems)	25	31	31	38	49	65	65	120	140	135	A
Current rating (380 - 460 V systems)	11	14	14	20	26	34	34	60	78	74	A
Recommended branch circuit fuse UL (200 - 230 V systems)	30	40	40	50	60	80	80	150	170	160	A
Recommended branch circuit fuse IEC (200 - 230 V systems)	25	35	35	35	50	65	65	120	140	135	A
Recommended branch circuit fuse UL (380 - 460 V systems)	15	20	20	25	30	40	40	75	95	90	A
Recommended branch circuit fuse IEC (380 - 460 V systems)	15	15	15	20	30	35	35	63	80	75	A
Min cable size for 200 - 230 V systems (or corresponding AWG size)	6 (8)*	6 (8)*	6 (8)*	10 (8)	10 (6)	16 (4)	16 (4)	35 (2)	50 (1/0)	50 (1/0)	mm ² (AWG)
Min cable size for 380 - 460 V systems (or corresponding AWG size)	6 (8)*	6 (8)*	6 (8)*	6 (8)*	6 (8)*	10 (6)†	10 (6)†	16 (4)	25 (4)	25 (4)	mm ² (AWG)
Mains connector for 200 - 230 V systems	Han [®] K 4/4	Han [®] K 4/4	Han [®] K 4/4	Han [®] K 4/4	Han [®] K 4/4	Han [®] 100A module	Han [®] 100A module	Han [®] 200A module	Han [®] 200A module	Han [®] 200A module	
Mains connector for 380 - 460 V systems	Han [®] K 4/4	Han [®] K 4/4	Han [®] K 4/4	Han [®] K 4/4	Han [®] K 4/4	Han [®] 100A module	Han [®] 100A module	Han [®] 100A module	Han [®] 100A module	Han [®] 100A module	-

* The minimum geometric wire gauge for Han[®] K 4/4 is 6mm² and minimum AWG size is 8 AWG.

† The minimum geometric wire gauge for Han[®] 100A module is 10mm² and minimum AWG size is 6 AWG.

Table 8 - General electrical data

Description	Rating	Units
Supply voltage 3-phase	either 200 - 230 or 380 - 460 (see rating plate)	V a.c.
Frequency	50/60	Hz
Wiring configuration	3 wire plus Earth (ground)	
Branch circuit protection requirement	Current rating, refer to Table 7 Fuse class gG (IEC 60269), UL class T, class J or class RK5, Bussmann type JJS or equivalent I ² t characteristic rated to 600 V	
Voltage tolerance range	+/- 10%	
Installation category	II (IEC 60664-1)	
Input supply voltage unbalance	Should not exceed 2% when assessed over any one minute period	
Short circuit current rating (when installed with class T or class J fuses)	200	kA
Second protective Earth (ground) conductor	Must be fitted with cross-sectional area at least equal to phase conductor size	
Maximum permitted overcurrent protection for systems with the Han [®] K 4/4 mains connector*		
for 200 - 230 V systems	60	A
for 380 - 460 V systems	35	A
Typical earth leakage [†]		
for 200 - 230 V systems:		
- For GXS750/2600 & GXS750/4200	9	mA
- For all other GXS systems	<5	mA
for 380 - 460 V systems:		
- For GXS750/2600 & GXS750/4200	18	mA
- For all other GXS systems	<10	mA

* If you use overcurrent protection above the ratings in [Table 7](#) for systems with the Han[®] K 4/4, the minimum cable sizes no longer apply and you must ensure that the pump cable size is appropriately rated and in accordance with local legislation and electrical regulations. Ensure that cable size is compatible with the mains connector, refer to [Table 9](#).

† Typical earth leakage values measured at steady-state conditions. Note that higher leakage currents may occur:

- i) Under transient conditions such as power on or pump acceleration.
- ii) With abnormal supply configurations such as a missing or earthed phase or unbalanced supply voltages. Contact Edwards for more information about configuration requirements for earth leakage reduction.

Table 9 - Electrical connections

Description	Mating connector description / external supply rating	Internal supply rating
Mains connection Refer to installation section for wiring diagram	Refer to Table 7 for the mains connector fitted to each variant. Connector is either: Harting Han® K4/4-F finger safe 09 38 008 2703, 6-16mm ² fine stranded wire (VDE 0295 class 5, refer to Table 10), 8.9mm max insulation diameter or Harting Han® Axial Screw module 100A (2 off required), part number of mating half suitable for 10 - 25mm ² wire is 0914 002 2753 or 0914 002 2751 for 16 - 35mm ² wire. Use fine stranded wire (VDE 0295 class 5, refer to Table 10). or Harting Han® Axial Screw module 200A (3 off required), part number of mating half suitable for 25 - 40mm ² wire is 0914 001 2763 or 0914 001 2762 for 40 - 70mm ² wire. Use fine stranded wire (VDE 0295 class 5, refer to Table 10).	
PDT interface Pin 1 Pin 2 Pin 3 Pin 4 Pin 5	XLR type 5-way plug	24 V d.c. 0.2 A 0 V 24 V Transmit data Receive data Not used
System interface Pin 1 Pin 2 Pin 3 Pin 4 Pin 5	XLR type 5-way plug	24 V d.c. 0.75 A* 0 V 24 V Transmit data Receive data Not used
Ethernet interface	Standard RJ45 type or Neutrik® EtherCon® RJ45	(IEEE802.3i 10 Base T Ethernet)
EMS interface External emergency stop switch Pin 1 - supply, Pin 2 - return <i>Note: If there is no external connection a link plug must be fitted to operate the pump.</i> Internal emergency stop switch Pin 3 - common, Pin 4 - normally open Comms 24 V supply Pin 5 - supply, Pin 6 - 0 V supply common Chassis	XLR type 6-way plug 30 V a.c. 1 A, 60 V d.c. 0.55 A	24 V d.c. 100 mA 24 V d.c. 0.75 A*

Table 11 - Water cooling system data (continued)

Description	Rating	Units
Minimum required pressure differential across supply and return	Refer to Tables 12 to 16	bar
Supply temperature range	5 - 40 *	°C
Water type	Treated or non-corrosive industrial	
Maximum particle size	0.2	mm ²
Acidity	7.0 to 10.5	pH
Hardness	<250	ppm of CaCO ₃ (<250 mg of CaCO ₃ per litre)
Total dissolved solids (TDS)	<1500	mg/l
Total suspended solids (TSS)	<10	mg/l
Specific conductivity	2000	µS/cm
Materials in contact with cooling water	Stainless steel, Nitrile, PTFE, brass, polyamide and fluoroelastomer	
Water inlet connection	3/8 inch BSP male (GXS160/250) 1/2 inch BSP male (GSXS450/750/2600/4200)	
Water outlet connection	3/8 inch BSP male (GXS160/250) 1/2 inch BSP male (GSXS450/750/2600/4200)	

* Maximum coolant temperatures may need to be reduced if Glycol or other coolants are used dependent on the dilution and type.

Table 12 - Water consumption data (GXS160/250/1750/2600)

Pump	Characteristics	
	Minimum flow rate required *	Minimum required pressure differential across supply and return†
Units	l/min	bar
GXS160	4	1
GXS160/1750	7	1
GXS250	4	1
GXS250/2600	7	1

* All GXS dry pumping systems have a valved cooling system which will cause coolant flow rate to vary in response to pump load conditions. Table 12 states the "minimum flow rate required" under worst case pump load conditions, when all valves are open. Flow rates need to be increased and/or coolant temperatures reduced if Glycol or other coolants are used dependent on the dilution and type.

† The differential pressure values given are the minimum differential pressures required across the water supply / return at the point of connection to the pump to achieve the desired flow when the solenoid valves are open.

Table 13 - Water consumption data (GXS450 only)

Ambient (°C)	Water Temperature (°C)		
	40	30	20
40	15 SLM 1.8 bar dP	12 SLM 1.5 bar dP	10 SLM 1 bar dP
30	12 SLM 1.5 bar dP	12 SLM 1.5 bar dP	10 SLM 1 bar dP
20	10 SLM 1 bar dP	10 SLM 1 bar dP	10 SLM 1 bar dP

Table 14 - Water consumption data (GXS450/2600/4200)

Ambient (°C)	Water Temperature (°C)		
	40	30	20
40	19 SLM 2 bar dP	16 SLM 1.5 bar dP	12 SLM 1 bar dP
30	16 SLM 1.5 bar dP	16 SLM 1.5 bar dP	12 SLM 1 bar dP
20	12 SLM 1 bar dP	12 SLM 1 bar dP	12 SLM 1 bar dP

Table 15 - Water consumption data (GXS750 only)

Ambient (°C)	Water Temperature (°C)		
	40	30	20
40	19 SLM 2 bar dP	15 SLM 1.2 bar dP	12 SLM 1 bar dP
30	15 SLM 1.2 bar dP	15 SLM 1.2 bar dP	12 SLM 1 bar dP
20	12 SLM 1 bar dP	12 SLM 1 bar dP	12 SLM 1 bar dP

Table 16 - Water consumption data (GXS750/2600/4200)

Ambient (°C)	Water Temperature (°C)		
	40	30	20
40	25 SLM 2 bar dP	20 SLM 1.3 bar dP	15 SLM 0.75 bar dP
30	20 SLM 1.3 bar dP	20 SLM 1.3 bar dP	15 SLM 0.75 bar dP
20	15 SLM 0.75 bar dP	15 SLM 0.75 bar dP	15 SLM 0.75 bar dP

2.7 DP clean high flow purge / solvent flush option

Table 17 - High flow purge / solvent flush data

Feature	Specification	Rating
Pneumatic valve gas supply	Nitrogen or clean dry air	2.5 - 6.9 barg (36 - 100 psig)
Pneumatic valve inlet connection	3/8 inch compression fitting	
High flow purge gas	Air, nitrogen or other inert gas which is compatible with process	Typically 170 slm (for GXS160 & GXS250 systems) and 185 slm (for GXS450 & GXS750 systems) at atmospheric pressure at purge inlet connection
High flow purge air filter	½ inch NPT male Available as a spare, refer to Section 7.4	
DP clean solvent flush fluid inlet connection	3/8 inch BSP male	
DP clean solvent suction pipe connection	3/8 inch BSP female	

Notes: 1. The high flow purge /solvent flush kit is available as an option.

2. The DP clean solvent suction pipe is supplied with the pump but not fitted.

2.8 External evacuation system

Pumpdown performance on dry pumping systems fitted with mechanical boosters can be further enhanced by the use of an External Evacuation System (EES) kit. The EES kit will only provide a performance improvement on pumpdown cycles lasting less than 30s to pressures below 0.1mbar. The EES kit must only be used on clean applications.

This page has been intentionally left blank.

3 Installation



WARNING

Obey the safety instructions in this section and take note of appropriate precautions. Failure to observe these instructions may result in injury to people and damage to equipment.



WARNING

The dry pumping system should not be operated with the enclosure panels removed.



WARNING

The dry pumping system contains electrolytic capacitors which may emit dangerous fumes under certain fault conditions. Ensure the dry pumping system is installed in a well-ventilated area.

Potential hazards on the dry pumping system include electricity, hot surfaces, process chemicals, lubricating oil, purge gas and water under pressure.

Detailed safety information is given in [Section 4](#) and Edwards Safety Manual Publication Number P400-40-100 Vacuum Pump and Vacuum Systems.

- A suitably trained and supervised technician must install the dry pumping system. Users can be trained by Edwards to conduct the tasks described in this manual, contact your local service centre or Edwards for more information.
- Do not remove the temporary cover or blanking plate from the dry pumping system inlet and exhaust until ready to connect the dry pumping system to the vacuum or exhaust extraction system. Do not operate the dry pumping system unless the inlet and exhaust are connected to the vacuum and exhaust extraction system.
- Vent and purge the process system (if the dry pumping system is to replace an existing pumping system) for 15 minutes before starting installation work. Refer to [Section 5](#).
- Disconnect the other components in the process system from the electrical supply so that they cannot be operated accidentally.
- Electrical, purge gas and water supplies are all potentially hazardous energy sources. Before carrying out any maintenance the supply of these sources should be locked and tagged out.
- Any unintended overflows or spills of oil or water must be removed immediately to avoid risk of slips.
- Obey all national and local rules and safety regulations when installing the dry pumping system. Consult Edwards Safety Manual Publication Number P400-40-100 Vacuum Pump and Vacuum Systems before pumping hazardous materials. This publication is available on request: contact your supplier or Edwards.
- Route and secure cables, hoses and pipework during installation to avoid possible risk of trips.
- Before locating the dry pumping system, ensure that the installation area is clean and free from debris and contamination (such as oil).

In order for the dry pumping system to perform to specification, appropriate facilities must be provided as detailed in this manual.

3.1 Locate the dry pumping system



WARNING

Suitable lifting equipment must be used to move the dry pumping system. It is too heavy to lift by hand.

Move the dry pumping system to its operating position using any of the following methods:

- Use a forklift or pallet truck to lift the dry pumping system.



WARNING

Do not exceed the topple angle when moving the dry pumping system. When using a forklift or pallet truck, adjust the forks to lift around the centre of gravity.

CAUTION

When using a forklift or pallet truck to lift the dry pumping system, be sure to insert the forks under the base rail on the side of the dry pumping system otherwise the exhaust may be damaged. The base rail has cut-outs for forklift access.

Refer to the installation drawings in [Appendix A1](#) for topple angle and centre of gravity information.

- Lift the dry pumping system by the eyebolts.



WARNING

Ensure that the maximum angle between paired slings used to lift the dry pumping system is 45°.

Each dry pumping system is provided with four lifting eyebolts to enable lifting, [Figure 2](#) item 4.

Ensure that all the lifting eyebolts are used when lifting the dry pumping system. Once the dry pumping system has been moved to its location, remove the lifting eyebolts and replace with the lifting eyebolt covers supplied with the dry pumping system.

3.1.1 Dry pumping systems with optional castors



WARNING

Dry pumping systems fitted with castors should only be wheeled short distances over flat surfaces. If the floor surface is uneven or has obstacles the dry pumping system should be lifted with suitable lifting equipment.

GXS dry pumping systems are supplied with an option of skids or castors. For dry pumping systems fitted with castors it is important to note that the castors are intended only to aid manoeuvre of the dry pumping system into its final operating position. Dry pumping systems should be moved near to their final operating positions using either a forklift or pallet truck or lifted via the eyebolts as described above.

Note that the force required to push a dry pumping system on its castors varies greatly depending on the surface finish and cleanliness of the floor and any slopes or inclines. The forces quoted in [Section 2.1](#) were measured on a flat and level concrete floor and are not necessarily representative of all industrial locations.

It is the user's responsibility to carry out a risk assessment of their own location and take appropriate measures to ensure that the dry pumping system is manoeuvred safely and in accordance with local and national manual handling guidelines.

3.1.2 Levelling the pump

The GXS dry pumping system must be located on a firm, level surface to ensure that it works correctly and is not damaged. The pump must be level to a maximum of 3 degrees in any direction, measured at the pump inlet. It can be located directly on the floor or on a frame. Ensure that access is possible to the emergency stop button (refer to [Figure 1](#), item 1). Guidance for access areas (general and service) is given in the installation drawings.

- Pumps with skids are provided with four floor mounting plates, [Figure 2](#), item 2. If necessary, fit shims (which must be supplied) to ensure that the dry pumping system is level.
- Pumps with castors are provided with four levelling feet, [Figure 3](#), item 21. Once the dry pumping system has been pushed into position, adjust the levelling feet to make sure that the dry pumping system is level and is not supported by the castors. Refer to the installation drawings in [Appendix A1](#) for suggested jacking height.

3.1.3 Securing the pump

To secure the pump in place to prevent inadvertent movement (for example during an earthquake), take note of the following:

- Dry pumping systems with castors are supplied with 4 off seismic restraints as detailed in the installation drawings.
- Dry pumping systems with skids are provided with 4 off mounting holes in the floor mounting plates as detailed in the installation drawings.
- All dry pumping systems can be secured by fitting bolts or studs (not supplied) through the mounting holes in either the mounting plates or seismic restraints. Use M16 (5/8 inch) bolts with shakeproof washers or other suitable anchor bolts of the same size.
- Ensure that bolt size and spacing is adequate for the loads anticipated and the strength of the floor or frame.
- To locate the pump directly on the floor, use a concrete foundation with a mass of at least 1.5 times the mass of the pump. Ensure the length and width of the foundation extend at least 100 mm (4 inches) beyond the dimensions of the pump.
- If vibration transmission is a concern, vibration isolators (not supplied) should be fitted between the mounting plates or seismic restraints and the bolt or stud.

3.2 Lubrication

The dry pumping systems are given a charge of oil before leaving the factory.

3.3 Connect the dry pumping system to the vacuum / exhaust system



WARNING

Pipe the exhaust to a suitable treatment plant to prevent the discharge of dangerous gases or vapours to the surrounding atmosphere.

WARNING

Do not operate the dry pumping system with the exhaust pipeline blocked. If the exhaust pipeline is blocked, the dry pumping system can generate exhaust pipeline pressures of up to 10 bar (10×10^5 Pa). Note that a pressure spike up to a maximum 15 bar (15×10^5 Pa) can be generated in the exhaust pipeline for less than 0.5 seconds if the inlet is instantaneously exposed to atmospheric pressure when the pump is running and the exhaust is blocked.

CAUTION

Dry pumping systems have a maximum continuous exhaust line pressure limit. Operation above the limit may damage the pumping mechanism.

GXS medium duty dry pumping systems have an exhaust pressure sensor which will initiate warnings and alarms when the pump is operated for at least 20 seconds above the limits given in [Table 24](#). The pump will continue to run with a warning present, however an alarm will cause the pump to stop.

GXS light duty dry pumping systems do not have an exhaust pressure sensor. The maximum continuous exhaust line pressure of these dry pumping systems should not exceed 0.4 barg.

For all pumps, it is the user's responsibility to provide an exhaust system with sufficient conductance to ensure the exhaust pressure limit is not normally exceeded.

CAUTION

Use a catchpot to prevent the drainage of condensate back into the dry pumping system. Condensate that drains back into the dry pumping system could damage the pump.

Do not reuse any O-ring or O-ring assembly and do not allow debris to get into the dry pumping system during installation.

When connecting the dry pumping system to the vacuum system, take note of the following:

- To get the best pumping speed, ensure that the pipeline which connects the vacuum system to the dry pumping system is the minimum length possible and has an internal diameter not less than the system inlet port.
- Ensure that all components in the vacuum pipeline have a maximum pressure rating which is greater than the highest pressure that can be generated in the dry pumping system.
- Incorporate flexible pipelines in the vacuum pipeline to reduce the transmission of vibration and to prevent loading of coupling joints. Edwards recommend using Edwards braided flexible pipelines. The pipelines should be rated for 110 °C.
- Adequately support vacuum/exhaust pipelines to prevent the transmission of stress to pipeline coupling joints.
- Incorporate a pressure gauge in the inlet pipeline to determine that the dry pumping system operates correctly.
- The dry pumping system inlet must be able to be isolated from the atmosphere and from the vacuum system if pumping or producing corrosive chemicals.
- The outlet of the exhaust pipe can have a check valve fitted which prevents the suck-back of exhaust vapours after the dry pumping system is shut down. The check valve also provides additional attenuation of the pulses in exhaust pressure.
- For all GXS750 dry pumping systems there is a limit to the length of NW50 pipeline that can be used between the pump exhaust connection and the facility exhaust. For GXS750 dry pumping systems with a check valve, the length of pipeline is limited to 1 metre. For GXS750 dry pumping systems without a check valve the length is limited to 3 metres. If these lengths are exceeded, the GXS750 pump will trip out due to high exhaust pressure. If the distance to the facility exhaust is greater than these limits, consider using an adaptor on the pump exhaust and a larger diameter pipeline.

- For pumps running on dusty processes Edwards recommend that the exhaust line is cleaned regularly as part of routine maintenance. Accumulation of dust in the exhaust line can reduce conductance and therefore increase exhaust pressure which may damage the pump. The frequency of exhaust line cleaning depends on the process. On very dusty applications, use a low-impedance inlet filter to reduce maintenance requirements.
1. Referring to [Figure 5](#), remove the temporary cover or blanking plate from the inlet of the dry pumping system. Take care not to drop screws, tools and so forth into the pump inlet. Retain the nuts, bolts, washers and blanking plate for future use. Retain the temporary cover for future use on non-contaminated pumps only. The inlet O-ring is supplied with the pump, it is fitted underneath the inlet flange cover.
 2. Use the O-ring supplied and suitable nuts, bolts and washers (not supplied) to connect the inlet flange ([Figure 2](#), item 5) to the vacuum system. The inlet flange is not designed for use with a trapped O-ring or centering ring. Use Edwards half claw clamps when connecting an ISO style foreline flange to the dry pumping system inlet. Refer to [Figure 5](#).
 3. Use the trapped O-ring and clamp supplied to connect the exhaust outlet ([Figure 2](#), item 3 or [Figure 3](#) item 20) to the exhaust extraction system.

Figure 5 - Connecting the pump inlet

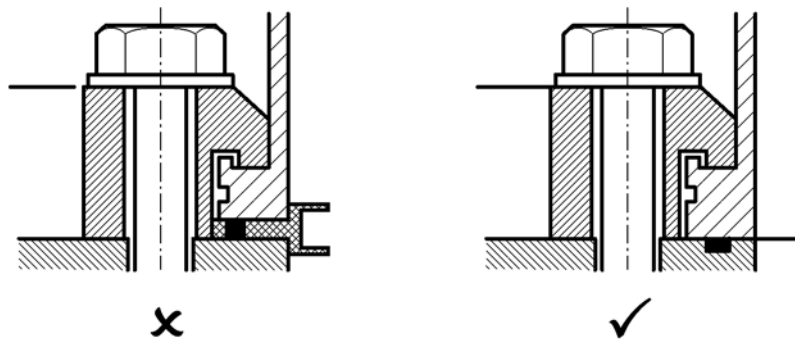

dcs/8651/016

Use Edwards half claw clamps:

Flange diameter	Half claw clamp part number	Qty required	Tightening torque (Nm)
ISO63	C10007093	4	5
ISO100	C10007093	8	5
ISO160	C10011093	8	5
ISO200	C10011093	12	5
ISO250	C10011093	12	5

3.4 Connect the purge gas supply

CAUTION

Ensure that the purge gas supply conforms to the requirements given in the technical data section. Failure to do so may cause the gas pipelines to become blocked or the dry pumping system to be damaged.

Refer to Figure 3, item 18 for location of the purge gas connection. Nitrogen and clean dry air are suitable purge gases for GXS dry pumping systems. To use a different purge gas, please contact Edwards.

Check visually that the rotameter is not damaged when installing the dry pumping system.

Note: Refer to Section 2.4 for purge gas supply requirements.

3.4.1 Flammable / pyrophoric materials



WARNING

Obey the instructions and take note of any precautions given below to ensure that pumped gases do not enter their flammable ranges.

When flammable or pyrophoric materials are present within the pump there may be additional risks that the user is responsible for assessing and managing as part of the entire process system installation. The severity of the risks and the necessary control measures will depend largely on whether the process system exhaust is in the flammable region, if this is part of normal operation, or if it might only occur under rare conditions. The additional risks arise because all dry pumps must be considered a potential source of ignition due to the heat of compression, or possibly friction. If ignition occurs then the following may happen:

- High pressures could occur within the pump and may not be contained.
- A flame front could travel back up the foreline.
- A flame front could travel downstream from the exhaust of the pump.

Industry best practice suggests that the following measures will reduce the risks of pumping flammable mixtures and pyrophoric materials, but it is the responsibility of the user to carry out a risk assessment and take appropriate measures:

- Do not allow air to enter the equipment.
- Ensure that the dry pumping system is leak tight.
- Ensure that gases in the pump do not enter the flammable range. This may be achieved by diluting gases in the pump by supplying sufficient inert gas purge. For example, dilution with nitrogen to below one quarter Lower Explosive Limit (LEL) or, if that is not practical, to below 60% Limiting Oxidant Concentration (LOC).
- The gas module supplied with the pump is not intended to perform a safety function. Users may need to consider adding appropriate measures to monitor the flow of purge gas, for example external sensors. Dry pumping systems that are fitted with the light duty gas module must not be used on applications pumping flammable or pyrophoric materials.

For further information please refer to Publication Number P400-40-100, Applications Note 'Pumping Flammable Gases' P411-00-090 or contact Edwards.

3.4.2 Gas purges



WARNING

If inert gas purges to dilute dangerous gases to a safe level are to be used, ensure that the pump is shut down if an inert gas supply fails.

Switch on the inert gas purge to remove air from the pump and the exhaust pipeline before the process starts. Switch off the purge flow at the end of the process only after the remaining flammable gases or vapours have been purged from the exhaust pipeline.

If liquids that produce flammable vapours could be present in the pump foreline, then the inert gas purge to the dry pumping system should be left on all the time this liquid is present. Flammable liquids could be present in the foreline as a result of condensation or may be carried over from the process.

When calculating the flow rate of inert gas required for dilution, consider the maximum flow rate for the flammable gases/vapours that could occur. For example, if a mass flow controller is being used to supply flammable gases to the process, assume a flow rate for flammable gases that could arise if the mass flow controller is fully open.

Continually measure the inert gas flow rate; if the flow rate falls below that required, then the flow of flammable gases or vapours to the pump must be stopped.

3.5 Leak test the dry pumping system

Figure 6 - Interspool connections on pump/booster combination systems

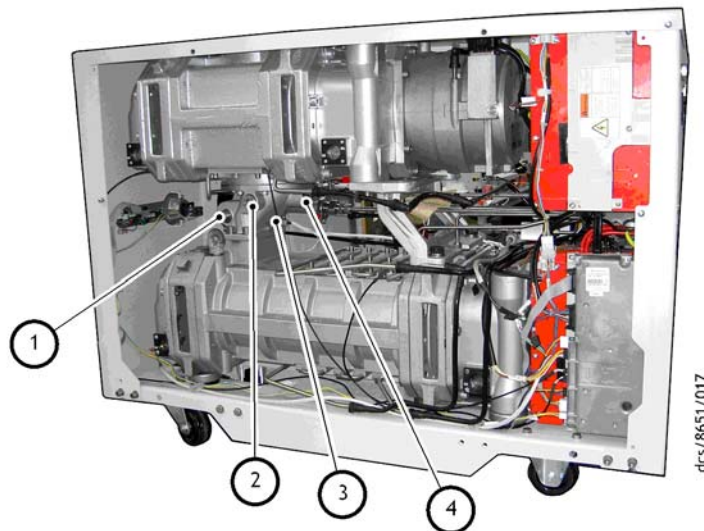

ID	Part identification
1	¼ inch BSP inlet port (available on dry pumping systems with light duty gas module only)
2	3/8 inch BSP port
3	Interspool
4	3/8 inch BSP port

WARNING



Leak test the dry pumping system after installation and seal any leaks found to prevent leakage of dangerous substances out of the dry pumping system and leakage of air into the dry pumping system.

The pump and booster combination systems have an interspool which has several ports that can be used for leak checking purposes. Remove the right hand side panel and refer to [Figure 6](#).

Note: For further information on leak testing, contact the supplier or Edwards for advice.

3.6 Electrical supply



WARNING

Ensure that the electrical installation of the dry pumping system conforms with all local and national safety requirements. It must be connected to a suitably fused and protected electrical supply and a suitable Earth (ground) point.



WARNING

This equipment is suitable for Installation Category II as defined in IEC 60664-1. The dry pumping system must be connected to an isolator that disconnects all current carrying conductors and can be locked out in the off position (LOTO). The isolator must be in close proximity to the equipment, within easy reach of the operator and identified as the disconnect device for the equipment.



WARNING

Isolate the electrical supply before disconnecting the electrical supply cable from the dry pumping system.



WARNING

Ensure that the dry pumping system and the electrical supply cable are suitably protected against Earth (ground) faults and that the Earth (ground) conductor of the electrical supply cable is longer than the phase conductors in the connector. A second protective Earth (ground) conductor (with a cross-sectional area at least equal to phase conductor size up to 16 mm²) must be fitted to the protective Earth (ground) stud, [Figure 3](#) item 15.



WARNING

All connections to the interface control must be double insulated or have equivalent protection. Do not connect voltages greater than 30 V a.c. or 60 V d.c. to the control/interface connections as the interface control will not provide protection against electric shock.



WARNING

The power wiring to the dry pumping system must be properly protected.

CAUTION

All dry pumping systems are supplied already configured for an electrical supply. The dry pumping system cannot be reconfigured between the low voltage (200 V to 230 V) and high voltage (380 V to 460 V) ranges.

CAUTION

This is an industrial (Class A) product as defined by EN61326. To ensure compliance with European Electromagnetic Compatibility (EMC) requirements for EMC emissions, please note that it is not intended for use in domestic buildings, or in properties directly connected to an electrical supply network which also supplies domestic buildings.

CAUTION

Do not connect voltages greater than specified in [Table 9](#) to the control/interface connections as it may cause damage to the interface control.

To use the dry pumping system with a power supply in a different voltage range to that specified on the rating plate, contact Edwards.

The dry pumping system is protected from motor overloads and short circuits by solid state electronics. The power wiring between the dry pumping system and the electrical installation must be protected. When selecting input fuses, refer to [Section 2.5](#). Pump rating information can be found on the label on the rear of the pump.

To connect the electrical supply to the dry pumping system through an ELCB (or RCD depending on territory) it must be suitable for protection of equipment with a d.c. component in the fault current, for short duration switch-on surges and for high leakage current (for example, type B, according to EN50178).

The secondary protective Earth (ground) is required in case of failure of the primary earth and because pump filters can cause high earth leakage currents, refer to [Table 8](#).

3.6.1 Mains supply cable connection



WARNING

The Harting connector is not approved for connection and disconnection under load.

Three different types of electrical supply connector are used on GXS dry pumping systems. A kit of parts containing the correct mating half connector is supplied with each dry pumping system. Refer to [Section 2.5](#) for details of the connector types and the dry pumping systems to which they are fitted. Information for wiring each of these different connectors is given in [Figures 7, 8 and 9](#).

Referring to either [Figure 7, 8 or 9](#) for the appropriate electrical connector for the dry pumping system, use the following instructions to make the electrical supply cable:

1. Refer to [Section 2.5](#) for cable sizes and type to determine the most appropriate cable for the dry pumping system.

Note: *The kit of parts for dry pumping systems with the Harting Han® 100A and Han® 200A axial screw modules may contain a choice of inserts suitable for different wire sizes as detailed in [Table 9](#). Ensure that the correct insert for the size of wire that is to be used is selected.*

2. Screw the cable gland onto the hood.

Note: *The connector kit for the Han® K 4/4 contains a choice of 5 different rubber inserts that are suitable for cables with various outside diameters. Select the most suitable rubber insert for the size of cable that is to be used.*

3. Pass the cable through the cable gland and hood. Cables must be bare-ended without ferrules to ensure correct clamping in the connector block.
4. Before starting the assembly, use the hex (Allen) key specified in the appropriate figure to ensure that all the axial cones of the connector insert(s) are screwed fully downward to completely open the contact chambers.
5. Carefully remove the cable insulation to the exact dimension specified in the appropriate figure. Do not twist the cable strands.
6. Referring to the appropriate figure to identify the connections, insert each wire completely into the contact chamber until the copper strands reach the bottom. Keep the cable in position while applying the recommended tightening torque.
7. Fit the earth (ground) wire to the Protective Earth connection as shown in the appropriate figure.

Note: *The Protective Earth connection on the Han® 100A and Han® 200A connectors is on the hinged frame. It may be necessary to use one of the cable shoes (supplied) to fit the earth (ground) wire. Choose the most appropriate shoe for the size of cable that is to be used.*

8. Screw the connector insert into the hood (using the hinged frame for the Han® 100A and Han® 200A axial screw modules) and then tighten the cable gland.

9. If required, fit the coding pins to the connector block as shown in the appropriate figure.

Note: *Harting (the manufacturer of the connector) states that after initial assembly, the recommended tightening torque must only be reapplied once in order to avoid damage to the individual cable strands.*

10. The dry pumping system has an electrical connector locking mechanism - there are two different types fitted depending on pump variant.

For the locking mechanism for all GXS160, GXS250 and GXS450 dry pumping systems, refer to Figure 10.

This locking mechanism requires use of a suitable screwdriver to release. Referring to [Figure 10](#), the dry pumping system is supplied with a protective cover (item 5) fitted and the locking mechanism (item 1) may be applied. The protective cover is held in place by two locking levers. Follow these instructions to fit the electrical supply cable:

- Slacken off the locking screw (item 3) by a few turns to loosen the locking mechanism if necessary.
- Move the locking mechanism (item 1) to the left as far as possible, then lift it up so that it rotates around the pivot screw (item 2) and clears the left hand lever (item 4).
- Push back both levers (item 4) to release the protective cover.
- Remove the protective cover and fit the electrical supply cable.
- Pull both levers back towards the user to lock the electrical supply cable connector in place.
- Push the locking mechanism down as far as possible and then push to the right so that it prevents the left hand lever from actuating.
- Tighten the locking screw (item 3) to firmly hold the locking mechanism in place.
- Connect the other end of the electrical supply cable to the electrical supply through a suitable isolator.

For the locking mechanism for all GXS750 dry pumping systems, refer to Figure 11.

This locking mechanism is held in place by two M5 locking nuts and requires use of a suitable spanner to release. Referring to [Figure 11](#), the dry pumping system is supplied with a protective cover (item 1) fitted and the locking mechanism (item 3) may be applied. The protective cover is held in place by two locking levers (item 2). Follow these instructions to fit the electrical supply cable:

- Slacken off the two locking nuts (item 4) by a few turns to loosen the locking mechanism.
- Move the locking mechanism (item 3) to the right as far as possible so that it clears the right hand lever (item 2).
- Push back both levers (item 2) to release the protective cover.
- Remove the protective cover and fit your electrical supply cable.
- Pull both levers back towards you to lock your electrical supply cable connector in place.
- Push the locking mechanism as far as possible to the left so that it prevents the right hand lever from actuating.
- Tighten the locking nuts (item 4) to firmly hold the locking mechanism in place.
- Connect the other end of the electrical supply cable to the electrical supply through a suitable isolator.

If further information is required about connecting the electrical supply, contact Edwards for advice.

Figure 7 - The Harting Han® K 4/4 cable-mounted connector

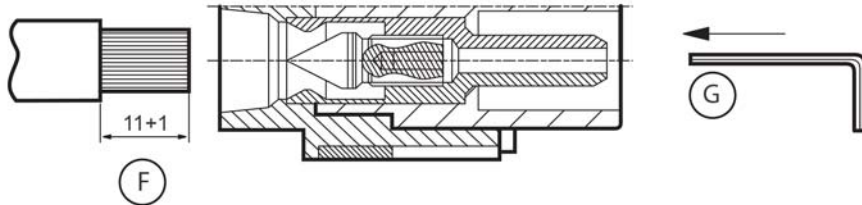
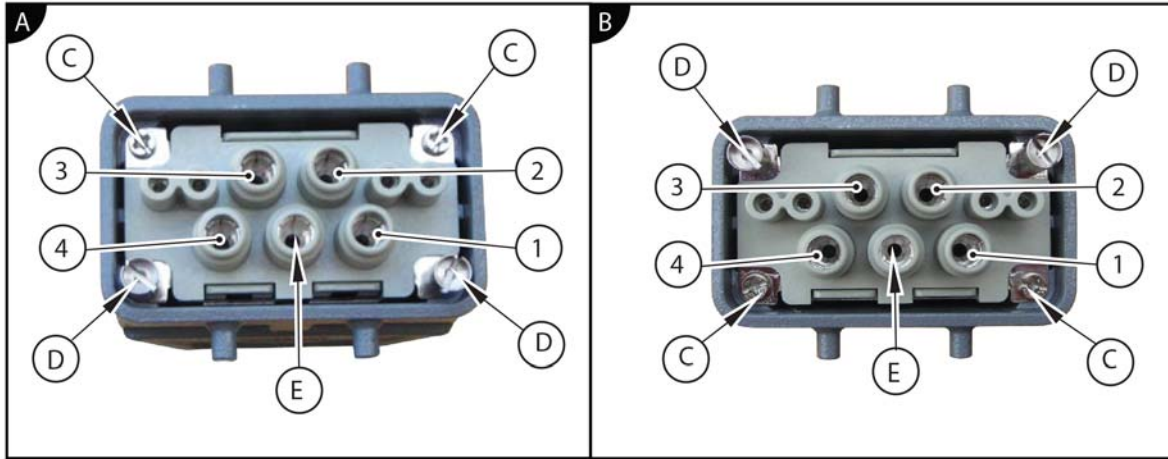

- A. Low volt pin configuration
 - B. High volt pin configuration
 - C. Mounting screw
 - D. Coding pin
 - E. Protective earth
 - F. Insert stranded wire
 - G. 2.5 mm hex (Allen) key
- 1. Pin 1 - Phase 1
 - 2. Pin 2 - Phase 2
 - 3. Pin 3 - Phase 3
 - 4. Pin 4 - Not connected

Torque settings for connector pins

Cable size (mm ²)	Max torque setting (Nm)
6	2
10	3
16	4

Figure 8 - The Harting Han® 100A axial screw module cable-mounted connector

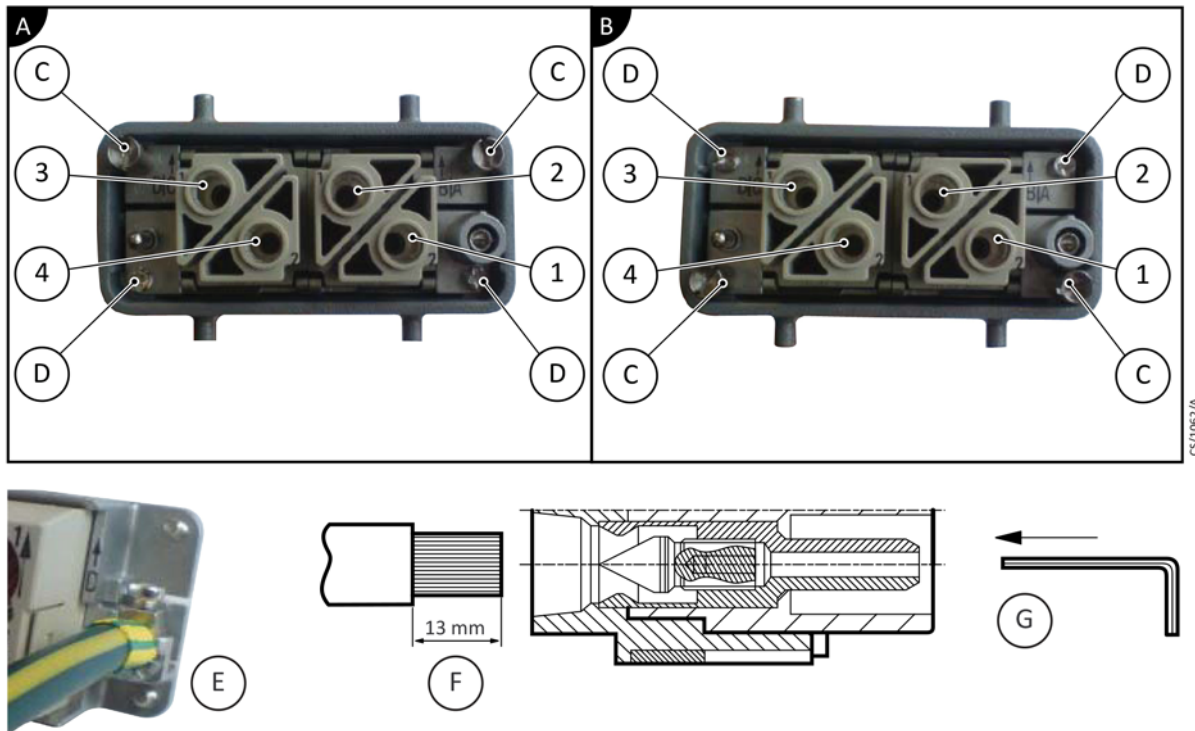

- A. Low volt pin configuration
 - B. High volt pin configuration
 - C. Coding pin
 - D. Mounting screw
 - E. View from cable side: connect Protective Earth into earth terminal
 - F. Insert stranded wire
 - G. 4 mm hex (Allen) key
- 1. Pin A2 - Phase 2
 - 2. Pin A1 - Phase 1
 - 3. Pin D1 - Not connected
 - 4. Pin D2 - Phase 3

Torque settings for connector pins

Cable size (mm ²)	Max torque setting (Nm)
10	6
16	6
25	7
35	8

3.6.2 Customer Connection Kit, Combination Low Volts GX5750

Tools and equipment:

- No 1 Pozidrive screwdriver
- 5 mm Hexagonal Allen key bit
- Torque driver set to 10 Nm

Figure 9 - Customer connection kit - combination low volts GXS750

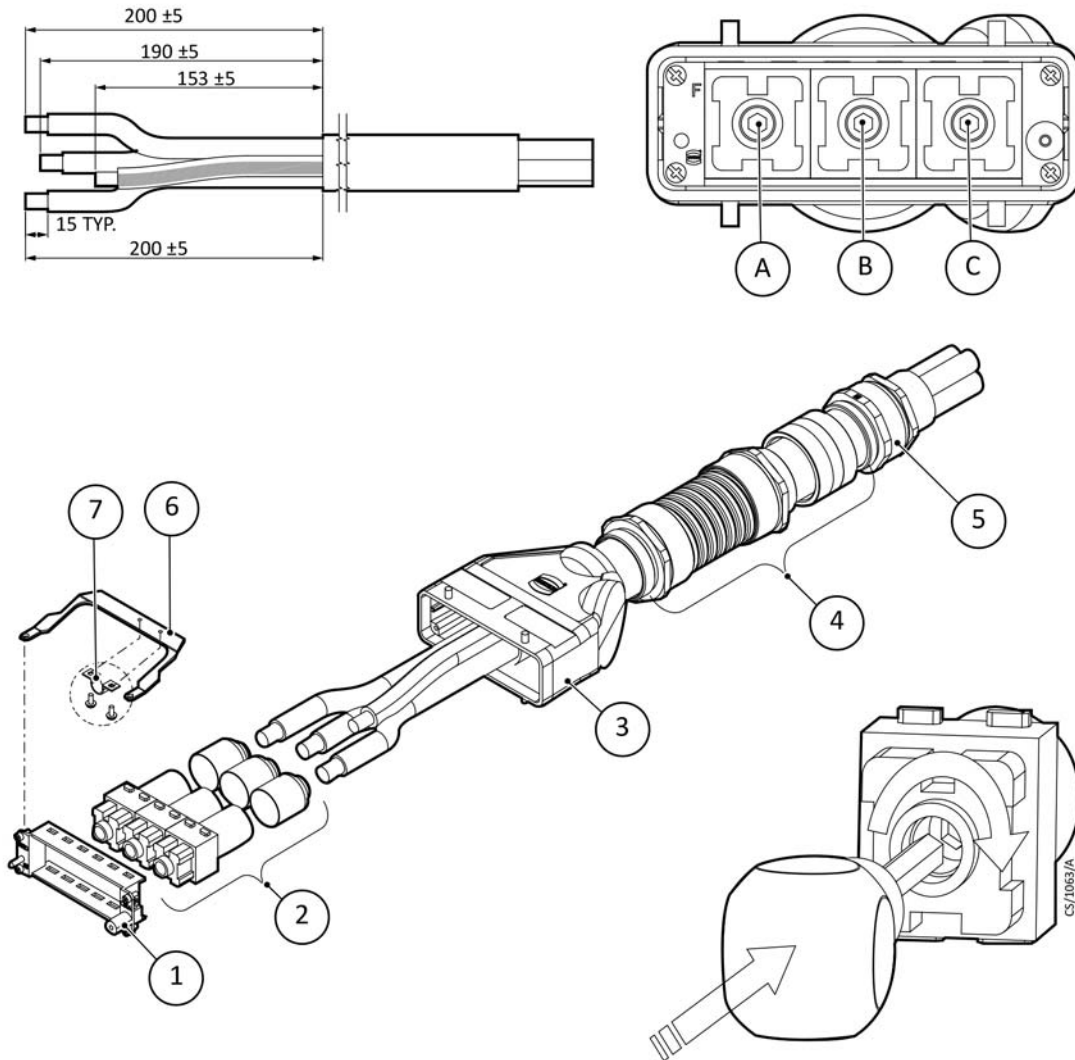

- A. Phase 3
- B. Phase 2
- C. Phase 1
- 1. 24 Frame hood 6 module A-F
- 2. 200A female insert 4 - 70 mm²
- 3. 24 Hood M50
- 4. Conduit sleeve kit 50 mm LV GXS
- 5. Cable gland M50 x 1.5
- 6. Earth terminal 24B LV connection kit GXS
- 7. Clamp for 10 mm cable diameter ground terminal

Figure 10 - Electrical connector locking mechanism for GXS160, GXS250 & GXS450 systems

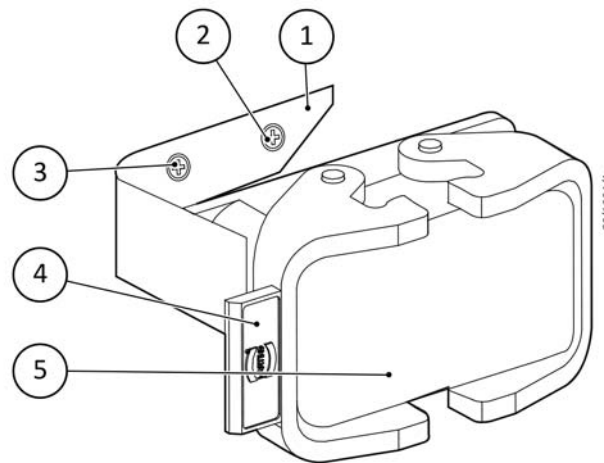

1. Electrical connector locking mechanism
2. Pivot screw
3. Locking screw
4. Lever (2 off)
5. Protective cover

Figure 11 - Electrical connector locking mechanism for GXS750 systems

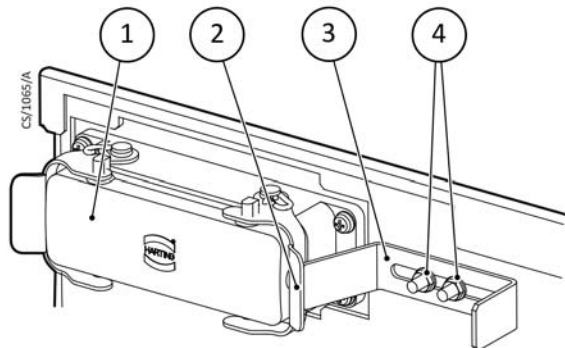

1. Protective cover
2. Lever (2 off)
3. Electrical connector locking mechanism
4. Locking nuts

3.7 Connect an additional RF earth (ground) (optional)

If the dry pumping system will be operated in an area subject to high Radio Frequency (RF) emissions, in accordance with good RF installation practice, Edwards recommend:

- Use a star washer to connect the end of the Earth (ground) cable (Figure 2, item 6) connected to the dry pumping system inlet to one of the bolts that are used to secure the inlet flange.
- Connect an additional Earth (ground) cable to the RF Earth (ground) stud (Figure 3, item 19). A suitable low-impedance cable must be used (for example, use braided cable).

3.8 Connect to your emergency stop circuit

Note: *If not connecting to own control equipment, the external EMS link plug supplied to the EMS connection on the rear of the dry pumping system (Figure 3, item 22) must be fitted. Failure to do so will result in not being able to operate the dry pumping system.*

If required, customer's own control equipment can be connected to the dry pumping system to shut it down in an emergency using the EMS connection (Figure 3, item 22). The emergency stop control must be compliant with IEC 60947-5-1. (This should be a red self latching mushroom push button on a yellow background).

3.9 Connect and set up cooling water



WARNING

Do not turn on the cooling water supply until after completion of the electrical installation of the dry pumping system or condensation may form inside the enclosure and there may be a risk of electric shock.

CAUTION

Remove both the outer dust caps and inner plastic plugs from the water inlet and outlet fittings before connecting the cooling water hoses.

CAUTION

Do not apply excessive torque to the water fittings when connecting the water supply to the dry pumping system as this may cause damage to the manifold. Use a suitable spanner to prevent the bulkhead fittings on the dry pumping system from turning whilst tightening up the connectors.

CAUTION

Fit the inlet strainer (supplied) into the supply side of the cooling water system to prevent damage to the cooling system within the dry pumping system.

Notes: 1. *For optimum water cooling, ensure that the cooling water supply meets the specification given in Section 2.6. Ensure water supplies are connected in parallel. Refer to Figure 3, items 17 and 13.*

2. *For minimum water consumption, regulate the cooling water flow to the dry pumping system.*

The dry pumping system is supplied with blue plastic dust caps fitted over the outside of the water inlet and outlet fittings and with red plastic plugs fitted inside these water fittings. Ensure that both sets of plastic plugs are removed before connecting the cooling water hoses, refer to Figure 12. Retain the plastic plugs for future use.

Figure 12 - Remove the plastic plugs from the water fittings

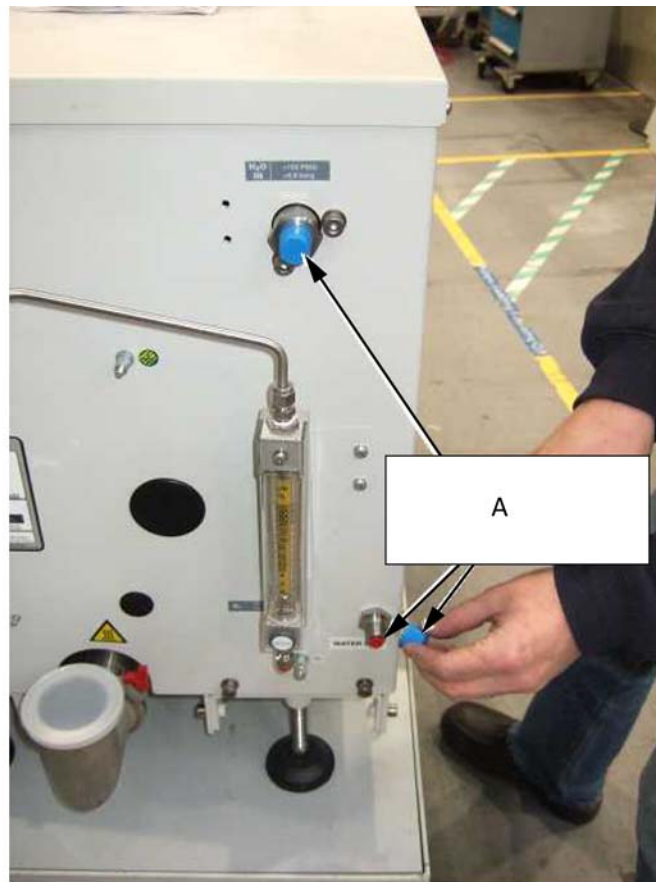

A. Remove outer (blue) caps and inner (red) plastic plugs

Fit the inlet strainer and then use the following procedure to connect the cooling water supply and ensure that the dry pumping system is receiving the correct water flow rate. Before starting, ensure that the electrical power supply to the dry pumping system is switched off:

1. Use BSP pipe fittings (not supplied) to fit to the cooling water supply and return hoses.
2. Connect the water return hose to the cooling water outlet (Figure 3, item 17). Fit a water flow meter into the water supply line close to the pump and then connect the water supply hose to the cooling water inlet (Figure 3, item 13). Take care not to turn the bulkhead fittings on the pump when tightening up the connectors.
3. Turn on the cooling water supply.
4. Switch on the electrical power to the dry pumping system. All the water valves in the pump cooling system will automatically open for a period of around 10 seconds.
5. Adjust the water flow rate so that it meets the requirements given in Table 12. Note that the water valves will all close again after 10 seconds and the flow rate displayed by the water flow meter will decrease - this is normal. If necessary, cycle the power to the pump to re-open the valves for a further 10 seconds to continue setting the water flow rate.
6. Once the water flow rate has been set the water flow meter may be removed.
7. Inspect the water hoses, pipelines and connections and check that there are no leaks.

Turn off the water supply while completing the remainder of the installation procedures.

3.10 Accessories



WARNING

When fitting accessories inside the GXS enclosure, ensure that the pump is switched off and lock and tag out the electrical supply before removing the enclosure panels.



WARNING

The surfaces of the dry pump, booster and spools are very hot when the GXS dry pumping system is running. Allow these surfaces to cool to safe temperatures before installing accessories inside the GXS enclosure. Be sure to route and secure accessory cables as shown in their individual installation manuals to prevent cables from resting on hot surfaces.

CAUTION

The power to the dry pumping system must be switched off when the MCM MicroTIM or active accessory module is installed or removed. If it is not, these modules may be damaged. Refer to the appropriate accessory manual for more information.

Refer to the individual accessories manuals for information about installation.

Refer to [Appendix A2.14](#) for instructions on how to set up the MCM MicroTIM using the PDT.

3.11 Commission the dry pumping system



WARNING

During some application cycles it is possible that the dry pumping system may exceed OSHA 1910.95 Occupational Noise Exposure Limits, the EU noise directive 2003/10/EC or other regional noise limits dependent upon the process, duty cycle, installation or environment in which the dry pumping system is being operated. A sound pressure survey must be conducted after installation and, if necessary, controls implemented to ensure that the relevant limits are not exceeded during operation and that adequate precautions are taken to prevent personnel from exposure to high noise levels during operation.

1. Switch on the external electrical supply and check that the power LEDs ([Figure 1](#), item 7 and [Figure 3](#), item 4) go on. If the LEDs do not go on, contact Edwards.
2. Switch on the cooling water and purge gas supplies.
3. Ensure that the exhaust extraction system is not blocked (for example, that valves in the exhaust extraction system are open).
4. Ensure that all openings to atmospheric pressure in the foreline vacuum system are closed.
5. Press and hold the local control button ([Figure 1](#), item 5) and check that the green local control LED ([Figure 1](#), item 6) comes on and then remains continuously illuminated.
6. Press START button ([Figure 1](#), item 3).
7. If the dry pumping system starts and continues to operate, continue at [Step 8](#). If a warning or alarm condition is indicated:
 - Shut down the dry pumping system: refer to [Section 4.4](#).
 - Contact Edwards.

8. Look at the pressure gauge in the inlet pipeline:
 - If the pressure is increasing, immediately shut down the dry pumping system and contact Edwards.
 - If the pressure is decreasing continue at [Step 9](#).
9. Visually check the purge gas rotameter on the rear of the pump to ensure purge gas is being delivered to the pump. Continue to check the rotameter on a regular basis as the dry pumping system is used.
10. After the dry pumping system is commissioned:
 - To continue to operate the dry pumping system, refer to [Section 4.1](#).
 - Otherwise, shut down the dry pumping system, refer to [Section 4.4](#).

3.12 Install additional safety equipment



WARNING

If the control system needs to know the total flow rate of purge gas to the dry pumping system for safety reasons, install suitable measurement equipment in the purge gas supply pipeline.



WARNING

If the gas purges are used to dilute dangerous gases to a safe level, ensure that the dry pumping system shuts down if the purge gas supply to the dry pumping system fails.

If the total flow rate of purge gas to the dry pumping system is required to be known for safety reasons, suitable measurement equipment should be fitted in the purge gas supply pipeline. If fitting a rotameter, ensure that it is suitable for use with the purge gas and that it is correctly calibrated. The rotameter supplied with the pump is not intended to perform a safety function, it is not calibrated and must be used for indication only.

Ensure that the installation is configured so that it remains safe if there is a failure of the purge gas supply to the dry pumping system.

If an alarm condition is detected the dry pumping system will shut down automatically. Ensure that the installation remains safe if the dry pumping system shuts down automatically.

3.13 Purge gas set up

There are two types of gas module used on GXS dry pumping systems, refer to [Section 2.4](#). The gas module configuration may be adjusted to suit process demands. Contact Edwards service personnel for instruction on how to access the gas valves menu (by the PDT) and for process-specific recommendations.

For dry pumping systems using the medium duty gas module, there is an adjustable needle valve fitted to the purge pipe which enables the adjustment of the level of gas ballast to suit the application.

Use the following procedure to adjust the gas ballast:

1. Remove the left hand side panel of the dry pumping system.
2. Identify the adjustable needle valve on the purge pipe (contact Edwards for guidance).
3. Adjust the needle valve until the required flow is met. Note that the rotameter on the rear of the pump measures total purge gas flow to the dry pumping system, including shaft seal and exhaust purge as well as gas ballast. The total purge flow is indicated by the position of the centre of the ball in the rotameter. Refer to [Section 2.4](#) for purge gas flows.
4. Refit the side panel.

For GXS450 and GXS750 dry pumping systems with the medium duty gas module there is an additional electronically-controlled gas ballast available for harsh applications. By default, these dry pumping systems are supplied with this additional gas ballast switched off but it can be enabled using the PDT.

Use the following procedure to enable the additional gas ballast:

1. Press the SETUP button on the PDT to enter the SETUP menu.
2. Scroll using the UP/DOWN keys and select the FIT ACCESSORY menu.
3. An access code is needed to enter the FIT ACCESSORY menu - enter 538 when prompted.
4. From the FIT ACCESSORY menu, scroll down to GAS BALLAST and then select ENTER.
5. Scroll down to 'Fitted' and press ENTER to select.
6. The additional gas ballast is now enabled.

3.14 High flow purge and solvent flush set up

WARNING



By default the DP clean high flow purge and solvent flush assembly draws atmospheric air into the GXS dry pumping system. If air is not compatible with the user's process then nitrogen or another inert gas may be used. It is the responsibility of the user to assess whether the DP clean purge gas is compatible with the process.

WARNING



Edwards only recommends use of water and diluted Loctite[®] 7840 or Loctite[®] Natural Blue[®] when performing a solvent flush procedure. It is the responsibility of the user to assess whether Loctite[®] 7840/Natural Blue[®] is compatible with the application - for more information refer to the Loctite[®] MSDS and technical data sheet. In particular the manufacturer states that Loctite[®] 7840 and Loctite[®] Natural Blue[®] are not recommended for use in pure oxygen and/or oxygen rich systems and should not be selected as a sealant for chlorine or other strong oxidizing materials.

For queries about solvent compatibility, contact Edwards applications specialists.

WARNING



Hot steam and liquid will exit the pump during the solvent flush procedure. Ensure that the exhaust is piped away safely and that any solvents are disposed of in accordance with local and national safety and environmental requirements.

CAUTION

If an inert gas is used in place of atmospheric air for the DP clean purge gas, ensure it is regulated to atmospheric pressure otherwise the DP clean process may not work properly and may cause damage to the pump.

The high flow purge and solvent flush procedures are performed by a single assembly which is supplied as an option fitted in the factory. The actuating valve is operated pneumatically. Ensure the pneumatic gas supply meets the specification given in [Section 2.7](#).

Use a 3/8 inch compression fitting (not supplied) to connect the pneumatic supply to the dry pumping system. For pump and booster combinations, the pneumatic inlet connection is on the rear pump panel, refer to [Figure 3](#) item 10. For pump-only systems, refer to [Figure 13](#), item 4.

The pneumatic regulator is pre-set to 50 ± 5 psig in the factory and does not need to be adjusted. The pneumatic regulator is shown in [Figure 13](#), item 5 for pump-only systems. For pump and booster combination systems, the regulator is contained within the pump enclosure.

To use an inert gas in place of atmospheric air as the DP clean purge gas, first remove the air filter and in its place connect up the inert gas supply. For pump and booster combinations, the air filter is on the rear pump panel, refer to [Figure 3](#), item 12. For pump-only systems, refer to [Figure 13](#), item 1. Refer to [Section 2.7](#) for information about fittings and typical purge gas flows.

A solvent suction pipe is provided with the pump. When only performing a high flow purge procedure the solvent suction pipe will not be needed. When performing a solvent flush, fit the solvent suction pipe only when ready to perform the DP clean procedure. For pump and booster combinations, the solvent flush fluid connection is on the rear pump panel, refer to [Figure 3](#) item 11. For pump-only systems, refer to [Figure 13](#), item 2.

A PDT is required to operate the DP clean high flow purge and solvent flush.

Figure 13 - DP clean assembly for pump only systems

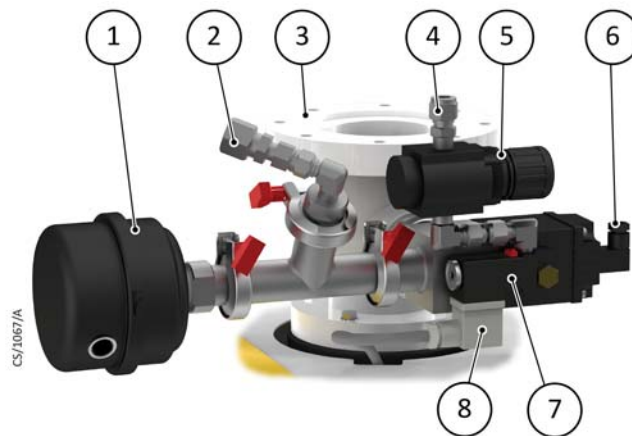

1. Air filter
2. DP clean solvent flush fluid connection
3. Inlet spool
4. Pneumatic valve inlet connection
5. Pneumatic regulator
6. Optional connection to pneumatic valve sensor
7. Pneumatic valve
8. Pneumatic valve electrical connection

3.15 Connecting the GXS dry pumping system for serial communications

3.15.1 Serial port connection

GXS dry pumping systems have two 5-way XLR sockets that can be used to connect the pump for serial communications. The user can connect by the PDT connector on the front of the pump, [Figure 1](#) item 11 and by the system interface on the rear of the pump, [Figure 3](#) item 5.

An adaptor cable, Edwards part number D373-70-754, is available as an accessory. The cable is 2 m long with a 5-way XLR plug on one end and a 9-way D connector socket on the other, allowing connection from the GXS dry pumping system to a standard COM port on a computer. Should the user prefer to make their own adaptor cable, refer to [Table 9](#) for the pin-out of the XLR connectors.

Note: Some personal computers no longer come equipped with a standard 9 way D connector COM port. In this case a USB to RS232 adaptor can be obtained.

For information about using SIM protocol with a serial port, refer to [Appendix A2.13](#).

3.15.2 Ethernet connection

Connect the Ethernet cable to the pump by the Ethernet connection on the rear of the pump, refer to [Figure 3](#) item 3. Refer to [Appendix A2.12](#) for information on how to set up and use the Ethernet port.

4 Operation



WARNING

Do not operate the dry pumping system with the lifting eyebolts still fitted or with any enclosure panels removed or damaged and do not touch any parts of the pump(s) when the dry pumping system is on. Surfaces of the pump(s) are very hot and can cause injury to people.



WARNING

Do not operate the dry pumping system with any enclosures removed or damaged as there may be a risk of an electric shock.

4.1 Start up



WARNING

Ensure that it is safe to start the dry pumping system. Failure to do so (and, for example, maintenance is being performed on components downstream of the dry pumping system), could cause injury to people.



WARNING

After the power is applied, all mains circuits will be energised.

CAUTION

The dry pumping system is designed to ride through transient power interruptions and to automatically restart once the power is restored.

CAUTION

Do not operate the pump if the pipeline is restricted or blocked as the pump will not operate correctly and may be damaged.

1. Switch on the cooling water and purge gas supply.
2. Switch on the electrical supply.
3. Check that the exhaust extraction system is not restricted and that any valves in the exhaust extraction system are open.

The pump can be started using either the MCM MicroTIM, the PDT, or the front panel control or by commands sent using the serial interfaces. Refer to [Section 1.4](#) for information about taking control of the dry pumping system.

4.1.1 MCM MicroTIM operation

If the dry pumping system is to be operated by the user's own control equipment by the MCM MicroTIM, ensure that no other devices have control of the dry pumping system. If another device does have control it must first be released before the pump can be started by the MCM MicroTIM.

- Use the control equipment to set the pump start/stop signal to the interface connector and check that the running LEDs are illuminated.
- The MCM MicroTIM takes control. The message 'MTIM IN CONTROL' will be displayed on the PDT if connected. The green Tool Control LED (Figure 3, item 9) on the rear panel will illuminate.

4.1.2 PDT operation

If the dry pumping system is to be operated using the PDT:

- Connect the PDT to the required PDT connection, front (Figure 1, item 11) or rear (Figure 3, item 5).
- Control must be taken with the PDT - press **Control** button. The message 'PDT1 IN CONTROL' will be displayed if the front connection is used and the message 'PDT2 IN CONTROL' will be displayed if the rear connection is used.
- Press **START**  button (refer to Appendix A2 for more information).
- Press **ENTER**.
- The dry pumping system will start and the Running LED on the pump and the Pump On LED on the PDT will flash whilst the pump is coming on and warming up. These LEDs will stop flashing and remain illuminated continuously once the pump is on-process.

4.1.3 Front panel control operation

To operate the dry pumping system using the front panel controls (refer to Figure 1):

- Press and hold the local control button (Figure 1, item 5). The green local control LED (Figure 1, item 6) will illuminate continuously when control is taken. The message 'Keys in Control' will be displayed on the PDT if connected.
- Press and hold the start button (Figure 1, item 3) until the pump starts. The running LED (Figure 1, item 2) and Green Mode LED (Figure 1, item 10) will both flash whilst the pump is coming on and warming up. Once the pump has warmed up and is ready for process, the running LED will remain illuminated continuously and the Green Mode LED will go off.

4.1.4 Start, warm-up and on-process sequences

GXS dry pumping systems are shipped with a number of pre-programmed sequences. Many of the parameters are configurable. Parameters can be configured using a PDT, refer to Appendix A2. The PDT is available as an accessory, refer to Section 7.3.

Table 18 - Start, warm-up and on-process sequences

Sequence	Description
Start pump	Shaft Seal Purge (SSP) valve opened. Pump runs.
Warm-up	Pump runs at 110 Hz until it reaches working temperature and then goes on-process [default auto on-process].
On-process	Inlet isolation valve opened (if fitted). Pump speed from standby (Green Mode) to full speed may be ramped by configurable increments instead of going straight to full speed. Pump will not go on-process if there are active warnings. Pump may be configured to ignore warnings and go straight onto process. Gas ballast is opened (if fitted, medium duty pumps only).

4.2 Status indicators

The GX5 dry pumping system has a number of LEDs that indicate pump status. The status LEDs are found on the front panel controls, refer to [Figure 1](#) and also on the rear panel, refer to [Figure 3](#).

Table 19 - Status indicator LEDs

Indicator Name	LED colour	Location	Meaning
Power	Green	Front panel (Figure 1 , item 7) and Rear panel (Figure 3 , item 4)	Illuminates continuously when the system has power.
Front Panel Control	Green	Front panel (Figure 1 , item 6)	Illuminates continuously to indicate the front panel is 'in control'.
Tool Control	Green	Rear panel (Figure 3 , item 9)	Illuminates continuously to indicate the MCM MicroTIM is 'in control'.
Pump Running	Green	Front panel (Figure 1 , item 2) and Rear panel (Figure 3 , item 7)	Illuminates continuously when the pump is running on-process. Flashes to indicate the pump is warming up, shutting down or in Green Mode/Standby mode. Refer to Section 4.2.1 .
Green Mode/ Standby	Green	Front panel (Figure 1 , item 10)	Illuminates continuously when pump is in Green Mode/Standby mode. Flashes to indicate the pump is warming up, refer to Section 4.2.1 .
Warning	Yellow	Front panel (Figure 1 , item 8) and Rear panel (Figure 3 , item 6)	Illuminates continuously to indicate a pump warning. Flashes to indicate an internal communication problem, refer to Appendix A3.5.1 .
Alarm	Red	Front panel (Figure 1 , item 9) and Rear panel (Figure 3 , item 7)	Illuminates continuously to indicate a pump alarm. Flashes to indicate an internal communication problem, refer to Appendix A3.5.1 .
Ethernet LAN	Green	Rear panel (Figure 3 , item 1)	Flashes to indicate that there is network traffic and Ethernet packets are being received.
Ethernet Link	Yellow	Rear panel (Figure 3 , item 2)	Illuminates continuously to indicate that an Ethernet protocol is active.

4.2.1 Determining pump status

It is not possible to fully determine pump status by referring to only one status LED. By looking at both the running LED and Green Mode/Standby LED together the user can work out pump status. Refer to [Table 20](#).

Table 20 - Pump status

Pump running LED	Green Mode/Standby LED	Pump status
Off	Off	Pump stopped
Flashing	Flashing	Pump is warming up
Flashing	Illuminated continuously	Pump is in Green Mode/Standby mode
Illuminated continuously	Off	Pump is on-process
Flashing	Off	Pump is shutting down

4.3 Green Mode/Standby mode

Green Mode is used to reduce the power and purge gas consumption of the pump when off process. All GXS dry pumping systems can support up to 9 different Green Mode configurations but, by default, only one Green Mode is enabled. To enable alternative Green Mode configurations please contact your local Edwards service representative.

To enable GREEN MODE/Standby mode when the pump is running and warmed up, press and hold the start button ([Figure 1](#), item 3) for 5 seconds. The pump GREEN MODE LED ([Figure 1](#), item 10) will illuminate continuously. The pump Running LED ([Figure 1](#), item 2) will flash.

To disable GREEN MODE/Standby mode, and therefore enable on-process mode, press and hold the start button ([Figure 1](#), item 3) for 5 seconds. If the pump has warmed up, the pump GREEN MODE LED ([Figure 1](#), item 10) will go out and the pump Running LED ([Figure 1](#), item 2) will illuminate continuously. If the pump has not warmed up, both the GREEN MODE LED and the pump running LED will flash until the pump is fully warm. The GREEN MODE LED will then go out and the running LED will illuminate continuously to indicate that the pump is now on-process.

Table 21 - Green Mode/Standby sequence

Sequence	Description
GREEN MODE/Standby	Inlet isolation valve closed (if fitted). Pump runs at standby (GREEN MODE) speed. Gas ballast valve closed (medium duty pumps only). If pump temperature drops below working temperature then it will start to warm up again. Pump ready line will be off if pump is not warmed up.

The GXS dry pumping system can also be set into GREEN MODE/Standby mode using the following methods:

- PDT, by the commands menu, refer to [Appendix A2.4.4](#).
- MCM MicroTIM, refer to the MicroTIM manual D373-60-880.
- By commands sent over the serial interface using the SIM protocol, refer to the SIM Manual P411-00-200, or using the E54 protocol.

4.4 Manual shut down



WARNING

If the dry pumping system is shut down and not isolated from the electrical supply, do not disconnect the Pump Display Terminal or release control from the Pump Display Terminal or front panel. This may result in the dry pumping system being started by another Module.



WARNING

Do not remove the inlet connections until the pump has been allowed to stop rotating and the power has been isolated. The pump can take up to three minutes to completely stop.

CAUTION

If the pump is stopped without the gas purge cycle on processes that have condensable or solid by-products then the pump may not restart.

CAUTION

For applications pumping liquids or condensable gases: if the pump is switched off straight after process then liquids may remain trapped in the pump. These liquids can corrode the pump mechanism whilst the dry pumping system is switched off for extended periods and may prevent the pump from starting again. For these applications Edwards recommend carrying out a Smart Stop with Stop Time set to the maximum 3600 seconds. Once the pump has stopped, seal the inlet and exhaust to prevent migration of liquid/condensable back into the pump mechanism.

The GXS dry pumping system has two manual shut down modes: Fast and Auto.

In Fast shut down mode, no gas purges are introduced and the pump stops quickly. This method of shut down is not recommended.

In Auto shut down mode, a purge gas cycle is introduced and the pump shuts down gradually over a time period. This is the recommended shut down mode and is the default mode on the dry pumping system.

Smart Stop is an additional sequence that allows the user to define the time period for the gradual shut down and to configure a setpoint temperature. If Smart Stop is enabled, the pump will perform a Smart Stop when the user selects Auto shut down.

Refer to [Table 22](#) for stop sequences.

Table 22 - Stop sequences

Sequence	Description
Stop with inlet purge	Inlet purge gas valve opened (medium duty pumps only). Inlet isolation valve closed (if fitted). Pump runs for 15 minutes before stopping. All gas purge valves closed before pump stops.
Smart Stop	Inlet purge gas valve opened (medium duty pumps only). Inlet isolation valve closed (if fitted). Pump speed is ramped down over configurable shut down time. All purge gas valves closed before pump stops. Pump stops after configurable shut down time or after a configurable time period after the pump temperature is below a configurable setpoint.

The pump can be shut down using either the MCM MicroTIM, the PDT or the front panel controls. Note that only the item in control can stop the pump (refer to [Section 1.4](#)).

Note: The EMS button will always stop the pump. It does not matter which item has control. Refer to [Section 4.7](#).

If the pump is not going to be required for some time, switch off the electrical supply and the cooling water supply. Seal the pump inlet and exhaust to prevent any moisture in the atmosphere from corroding the pumping mechanism.

4.4.1 MicroTIM operation

Use the control equipment to reset the pump start/stop signal to the interface connector. The Running LEDs will then go off and the pump running status output signal will open. An Auto shut down cycle is always performed when the pump is stopped using the MCM MicroTIM.

4.4.2 PDT operation

Press the stop  button on the PDT (refer to [Appendix A2](#) for more information). Choose whether to select Auto or Fast shut down mode.

4.4.3 Front panel control operation

Press and hold the stop button ([Figure 1](#), item 4) for 5 seconds to stop the pump in Auto shut down mode (recommended). Repeat within 10 seconds to stop the pump in Fast shut down mode. The running LED ([Figure 1](#), item 2) flashes whilst the pump is slowing down and will then turn off when the pump has shut down.

4.5 Automatic shut down

Normally, if an alarm condition exists, the control system will shut down the dry pumping system. When the dry pumping system shuts down, all the purge gas valves close and the pump stops. For dry pumping systems containing a dry pump and booster combination, some alarms will cause only the booster to stop, and not the full dry pumping system.

Table 23 - Alarm actions

Alarm description	Alarm stops dry pump	Alarm stops booster pump
EMS or system configuration fault	Yes	Yes
Exhaust pressure [*]	Yes	Yes
Booster stator temperature [†]	No	Yes
Dry pump stator temperature	Yes	Yes
Booster status [†]	No	Yes
Dry pump status	Yes	Yes

^{*} Not applicable to systems with light duty gas module.

[†] Not applicable to systems which do not contain a booster.

4.6 Unplanned shut down and alarms

The dry pumping system is fitted with a number of pump protection sensors that will give warnings and alarms, refer to Table 24.

Table 24 - Pump protection sensors

Sensor	Warning condition triggered	Alarm condition triggered
Exhaust pressure transducer*	0.3 barg (4.4 psig)	0.4 barg (5.8 psig)
DP TEMP temperature		
GXS160 and GXS160/1750	150 °C	160 °C
GXS250 and GXS250/2600	150 °C	165 °C
All GXS450 dry pumping systems	170 °C	180 °C
All GXS750 dry pumping systems	180 °C	190 °C
MB Stator temperature	120 °C	130 °C

* Not available on dry pumping systems with the light duty gas module.

Refer to Section 4.5 for information about alarms and automatic shut down conditions.

If the dry pumping system has an unplanned shut down, ensure that the cause of the shut down is identified and rectified before restarting. If in doubt, contact Edwards.

Note: The high temperature alarms on Edwards dry pumping systems are dry pumping system protection trips and should be considered as an abnormal running condition. If a dry pumping system has tripped due to any high temperature alarm it should be investigated and the reason for the alarm established. Once the fault has been remedied the dry pumping system should be left for a minimum of 30 minutes before attempting to restart.

4.7 Emergency stop

Note: The emergency stop switch is not an electrical isolator.

To shut down the dry pumping system in an emergency, press the emergency stop switch (Figure 1, item 1). Alternatively, the emergency stop controls can be operated in the user's own control system if the emergency stop circuit has been connected to the dry pumping system as described in Section 3.8.

When emergency stop is selected:

- The dry pump and the booster pump are switched off.
- The solenoid valve(s) in the gas module close, to switch off the supply of purge gas to the pump.
- The solenoid valve(s) in the temperature control manifold(s) de-energise with loss of temperature control.
- The PDT will display 'ALARM 1.01/STOP ACTIVATED' (if connected) or it may display 'ALARM 186.01/ DP INV 0040 0000 / EMS'.
- The running LED will go off.
- The alarm LED illuminates.

4.8 Restart the pump after an emergency stop or automatic shut down

Note: *If the dry pumping system has automatically shut down because of high pump power, check that the pump is free to rotate before restarting the dry pumping system: contact Edwards.*

If the emergency stop switch on the front panel has been used to shut down the dry pumping system, the emergency stop switch must be reset before the dry pumping system can be restarted. Turn the emergency stop switch to reset it, then restart the dry pumping system as described in [Section 4.1](#).

If the dry pumping system has been automatically shut down because of an alarm condition, the alarm condition must be rectified before the dry pumping system can be restarted. If the alarm was caused by high pump temperatures, refer to [Section 4.6](#). Restart the dry pumping system as described in [Section 4.1](#).

4.9 Dry pump clean

The high flow purge and solvent flush kit is available as a factory-fit option to clean the pump mechanism on applications where large quantities of dust and sticky deposits are encountered. The cleaning process is run while the pump is in Green Mode/Standby mode and is carried out without the need to remove the pump enclosure. A PDT is required to initiate the DP clean process. Refer to [Table 25](#) for details.

Table 25 - DP clean sequence

Sequence	Description
Dry pump clean	<ul style="list-style-type: none"> ● Only operates when the pump is running in Green Mode/Standby mode. ● Purge gas or solvent fluid is admitted into the pump for a configurable time period (default 20 minutes). ● Pump speed during dry pump clean is configurable (default 80 Hz). ● Gas purges may be configured to be on during the clean cycle and/or for a period after the DP clean valve has closed (default off). ● Pump is not able to go on-process until cycle has completed. ● If dry pump clean is stopped by the user then the purge cycle is completed. ● DP clean may be configured to start automatically when the pump goes off process.

The DP clean high flow purge and solvent flush procedures can be run as often as required.

4.9.1 High flow purge

Use the following procedure to prepare for the high flow purge:

1. Set up the GXS dry pumping system ready for the high flow purge procedure as described in [Section 3.14](#).
2. Put the pump into Green Mode/Standby mode (refer to [Section 4.3](#)).
3. Using the PDT, press the **Setup** button to enter the setup menu and then select the **Command** menu. An access code is needed to enter the **Command** menu - enter 202 when prompted.
4. Scroll down to the **DP clean** menu and then press **ENTER** to select.
5. Select 'DP clean on' to start the high flow purge procedure.

The DP clean sequence will run automatically without requiring any operator intervention. Once the DP clean time has elapsed, the dry pumping system will return back to Green Mode/Standby mode settings. The pump can then be put back on-process.

To stop the high flow purge process whilst it is running, enter the **DP clean** menu again using the PDT and select 'DP Clean off'.

The DP clean procedure can be configured to suit the user's application, refer to [Appendix A2.9](#).

4.9.2 Solvent flush



WARNING

Use of suitable protective gloves and eye protection is recommended when carrying out the solvent flush procedure. Personal protective equipment should be checked and used as specified by its supplier. Refer to the Loctite[®] 7840 or Loctite[®] Natural Blue[®] MSDS for more information.



WARNING

Take care when handling solvents and water. Any overflows or spills should be cleaned up to avoid risk of slips.



WARNING

Hot steam and liquid will exit the pump during the solvent flush procedure. Ensure that the exhaust is piped away safely and that any solvents are disposed of in accordance with local and national safety and environmental requirements.

Use the following procedure to perform the solvent flush procedure:

1. Set up the GXS dry pumping system ready for the solvent flush procedure as described in [Section 3.14](#) and take note of the safety warnings regarding process compatibility.
2. Fit the solvent suction pipe supplied. For pump and booster combination systems, the solvent flush fluid connection is on the rear panel, refer to [Figure 3](#), item 11. For pump-only systems, refer to [Figure 13](#), item 2.
3. Make up 5 litres of solvent solution using 1 litre of Loctite[®] 7840 or Loctite[®] Natural Blue[®] with 4 litres of water. Keep this ready in a suitable container.
4. Measure out another 2.5 litres of water into a separate container.
5. Put the pump into Green Mode/Standby mode (refer to [Section 4.3](#)).
6. Put the free end of the solvent suction pipe right down to the bottom of the container holding the 5 litres of solvent solution.
7. Using the PDT, press the **Setup** button to enter the setup menu and then select the **Command** menu. An access code is needed to enter the **Command** menu - enter 202 when prompted.
8. Scroll down to the **DP Clean** menu and then press **ENTER** to select.
9. Select 'DP Clean On' to start the solvent flush procedure. The solvent solution will then gradually be drawn into the pump.
10. Depending on pump size it typically takes around 4-7 minutes to draw through the 5 litres of solvent solution (larger pumps draw the liquid through more quickly than smaller pumps). Once the full 5 litres of solvent solution have been drawn through, put the free end of the solvent suction pipe right down to the bottom of the container holding the 2.5 litres of water. The water will flush through any solvent solution remaining in the pump mechanism.
11. The pump typically takes another 2 - 4 minutes to draw through the water. Once all the water has been drawn into the pump, the DP clean process continues with a purge cycle, drawing air or purge gas into the pump to dry out the mechanism for the rest of the clean time.

- Notes:**
1. *If monitoring the state of the solvent that exits the pump to determine whether the pump is clean take special care because solvent solution initially exits the pump as steam and then as hot liquid with typical temperature of 75 °C.*
 2. *The exhausted liquid will never run clear. Exhausted liquid from a 'clean' pump has a similar viscosity to water (not thick and viscous) and is a light rust colour when seen exiting the exhaust.*
 3. *Depending on the application, the solvent flush process may need to be repeated, contact Edwards for advice.*
 4. *If the pump takes an abnormally long time to draw in fluids, there may be a problem with the high flow purge and solvent flush kit. A blocked orifice or leaks in the solvent suction pipe or pneumatic gas line are the most likely causes. Investigate the problem and rectify before continuing to use the solvent flush procedure. If in doubt, contact Edwards.*

Once the DP clean time has elapsed, the dry pumping system will return back to Green Mode/Standby mode settings. The pump can then be put back on-process.

To stop the solvent flush process whilst it is running, enter the DP Clean menu again using the PDT and select 'DP Clean off'. The pneumatic valve will shut, stopping the flow of solvent into the pump. If DP Clean has been configured to run an inlet purge cycle after the clean cycle, sending a 'DP Clean off' command will initiate the purge cycle. To stop the purge cycle as well, the PDT must be used to select 'DP Clean off' for a second time.

The DP clean procedure can be configured to suit the user's application, refer to [Appendix A2.9](#).

4.10 Pump speed control and PID

For some applications it is important to be able to adjust the speed of the pump whilst it is on-process, either to a set speed or to control the speed continuously to maintain a process pressure. The GXS dry pumping system has capability to run both the dry pump and booster at various speeds whilst on-process and it is possible to configure these speeds by a number of different methods. Refer to [Appendix A2.10](#) for more information about how to set up speed control options.

The GXS dry pumping system has a built-in Proportional-Integral-Derivative (PID) controller. When the PID function is enabled and the pump is on-process, the PID controller continually adjusts the speed of the pump so that a user-determined pressure is maintained at the chosen pressure sensor.

For more information about enabling and setting up the PID controller, refer to [Appendix A2.11](#).

5 Maintenance



WARNING

Only personnel specially trained to perform electrical maintenance should attempt troubleshooting inside electrical enclosures. These enclosures contain hazardous voltages and are not operator areas.



WARNING

Leak test the dry pumping system after maintenance and seal any leaks found to prevent leakage of dangerous substances out of and leakage of air into the dry pumping system.

5.1 Safety and maintenance frequency



WARNING

Obey the safety instructions given below and take the appropriate precautions. Failure to do so can cause injury to people and damage to equipment.



WARNING

Electrical, purge gas and water supplies are all potentially hazardous energy sources. Before carrying out any maintenance the supply of these sources should be locked and tagged out.



WARNING

Personal protective equipment should be checked and used as specified by its supplier. Hazardous chemicals that have been pumped are located within the pumps and piping. Use of suitable protective gloves and clothing along with a respirator is recommended if contact with substances is anticipated. Particular caution should be exercised when working with fluorinated materials which may have been exposed to temperatures greater than 260 °C. Refer to Edwards Safety Data Sheets for detailed information.

- Ensure that the maintenance technician is familiar with the safety procedures which relate to the products pumped.
- Allow the pumps to cool to a safe temperature before fitting lifting eye bolts or starting maintenance work.
- Vent and purge the dry pumping system before starting any maintenance work.
- Isolate the dry pumping system and other components in the process system from the electrical supply so that they cannot be operated accidentally. Note that the emergency stop switch on the dry pumping system is not an electrical isolator.
- Wait for at least four minutes after switching off the electrical supply before touching any electrical component on the dry pumping system.
- Route and secure cables, hoses and pipelines during maintenance to avoid possible risk of trips or entrapment.
- The enclosure panels should only be removed when the dry pumping system has been switched off and allowed to cool sufficiently (as an indication the dry pumping system should be left for one hour with cooling water still connected with flow characteristics as defined in [Section 2](#)).

- Wear the appropriate safety clothing when coming into contact with contaminated components. Dismantle and clean contaminated components inside a fume cupboard.
- Re-check the pump rotation direction if the electrical supply has been disconnected.
- O-ring replacement intervals vary depending on the application.
- Dispose of components, grease and oil safely.
- Take care to protect sealing faces from damage.
- Do not touch or inhale the thermal breakdown products of fluorinated materials which may be present if the dry pumping system has been overheated to 260 °C and above. These breakdown products are very dangerous. Fluorinated materials in the dry pumping system include oils, greases and seals. The dry pumping system may have overheated if it was misused, if it malfunctioned or if it was in a fire. Edwards Safety Data Sheets for fluorinated materials used in the pump are available on request.

The dry pumping system requires little operator maintenance between overhauls. Pump protection sensors fitted to the dry pumping system do not require routine maintenance. The maintenance operations that can be carried out are described in the following sections. The frequency of maintenance operations depends on the process. Adjust the frequency of maintenance operations according to user experience.

When maintaining the dry pumping system, use replacement parts, seals and fittings supplied by Edwards, refer to [Section 7](#). Ensure that the purge gas and cooling water supplies are connected in parallel and that they meet the specifications given in [Section 2](#). Contact Edwards for more information.

Note: If the pump is controlled by the MCM MicroTIM then all the configuration options for accessories and set sequences are stored in the MCM MicroTIM and not in the pump. This means that if a replacement pump is swapped in it will be unnecessary to configure these options again if using the same MCM MicroTIM.

5.2 Relocate the dry pumping system for maintenance

WARNING



The substances that accumulate in the exhaust pipe, elbow and check valve can be dangerous. Do not allow these substances to come into contact with skin or eyes. Do not inhale vapours from these substances. Fit blanking caps to the inlet and outlet flanges when moving the exhaust pipe, elbow or check valve around the workplace.

The majority of synthetic oils/grease can cause inflammation of the skin (dermatitis). Safety precautions must be taken to prevent prolonged skin contact with these substances. Use of suitable protective gloves and clothing along with a respirator is recommended if contact with the substance is anticipated. System process gases and residue can be highly toxic. Take all necessary precautions when handling components that have, or could have, come into contact with them, including O-rings, lubricants and all exhaust accessories.



WARNING

Suitable lifting equipment must be used to move the dry pumping system. It is too heavy to lift by hand.



WARNING

Remove bulky accessories such as inlet filters, silencers and knock out pots before moving the dry pumping system because they can make the dry pumping system unstable. Do not exceed the topple angle of 10 ° when moving the pump.

CAUTION

Drain the cooling water from the dry pumping system if transporting or storing it in conditions where the cooling water could freeze. Failure to do so could result in the cooling water freezing in the dry pumping system and damage occurring to the pump(s) and/or the cooling water pipelines.

To remove the dry pumping system from its operating location and move it to another location to carry out maintenance, use the following procedure:

1. Purge the dry pumping system and shut down as described in [Section 4](#) and allow the dry pumping system to cool down.
2. Isolate the power and then disconnect the mating half from the electrical supply connector, then isolate the water and the gas purge supply.
3. Disconnect the purge gas supply, taking care as any trapped gas under pressure is released. Disconnect the cooling water supply followed by the cooling water return.
4. Disconnect the inlet and outlet from the vacuum and exhaust systems, remove bulky accessories such as filters, silencers and knock out pots and then fit blanking caps.
5. If necessary disconnect any other accessories from the dry pumping system.
6. For dry pumping systems with castors, adjust the levelling feet so that the dry pumping system rests on the castors.
7. Move the dry pumping system to the location where maintenance will be carried out.

After maintenance is complete, re-install the dry pumping system as described in [Section 3](#).

5.3 Draining the cooling water



WARNING

Use of suitable protective gloves and eye protection is recommended when carrying out this procedure. Personal protective equipment should be checked and used as specified by its supplier.

1. Relocate the dry pumping system for maintenance as stated in [Section 5.2](#).
2. Connect a regulated clean dry air supply (5 barg or 73 psig) to the cooling water supply connection ([Figure 3](#), item 14). Do not turn on the air supply yet.
3. Connect a drain hose to the cooling water return connection ([Figure 3](#), item 17). Position the open end of the drain hose in a suitable collection container.
4. Turn on the clean dry air supply.
5. Monitor the drain hose outlet until no further cooling water is purged.
6. Fit the external EMS link plug (supplied) to the EMS connection on the rear of the dry pumping system ([Figure 3](#), item 22). Failure to do so will result in not being able to purge the water system effectively.
7. Connect the dry pumping system to a suitable mains electrical supply. The control system will now open each temperature control valve, purging the cooling water from all flow paths. After two minutes, remove the electrical supply. Wait for 10 seconds and then re-connect the electrical supply and repeat the entire process. Continue repeating until no further cooling water is purged from the dry pumping system.

8. The cooling water drain procedure is now complete. Disconnect the air supply, electrical supply and the drain hoses. Dispose of the drained cooling water appropriately.

5.4 General maintenance

CAUTION

Do not use cleaning materials based on strong alkalis, aggressive or chlorinated solvents. Do not use cleaning materials containing abrasives.

The following maintenance can be carried out on the dry pumping system between overhauls, contact Edwards for details and training:

- Check the oil level, see [Section 5.4.1](#).
- Inspect the connections, pipelines, cables and fittings, see [Section 5.4.2](#).
- Inspect and clean exhaust pipe, elbow and check valve.

5.4.1 Checking the oil levels and refilling



WARNING

Use of suitable protective gloves and eye protection is recommended when carrying out this procedure. Personal protective equipment should be checked and used as specified by its supplier.

CAUTION

Ensure that the oil levels in the dry pump and the mechanical booster pump (where applicable) are correct. If a pump oil level is incorrect, pump performance may be affected and the pump may be damaged.

The dry pump and booster (if fitted) each have two sight glasses. One is located on the end cover, refer to [Figure 14](#), and the other is located on the gearbox, refer to [Figure 15](#). Note that the GXS750 dry pumping system has a gearbox with a sight glass at each end and so [Figure 15](#) applies to both ends. One is accessible from the left hand side of the dry pumping system and the other is accessible from the right hand side.

GXS 450, 450/2600, 450/4200, 750, 750/2600 and 750/4200 dry pumping systems are provided with slots in the side panels to enable the oil levels to be checked without removal of the side panels. To check oil levels on these systems:

1. Switch off the dry pumping system and allow it to stand for at least 5 minutes.
2. Check that the oil level is in line with the MAX indicator. If the oil level is below the maximum it must be topped up.

All other GXS pumps require the dry pumping system side panels to be removed in order to check the oil level. To check oil levels on these systems:

1. Switch off the dry pumping system and allow it to stand for at least 5 minutes.
2. Remove the side panels.
3. Check that the oil level is in line with the MAX indicator. If the oil level is below the maximum it must be topped up.

To top up the oil levels, all GXS pumping systems require side panels to be removed:

1. Refer to [Figures 14](#) and [15](#) to locate the oil fill plugs on the top of the end cover and gearbox.
2. Remove the appropriate oil fill plug and carefully top up with oil, refer to [Section 2.1](#) for specification.
3. Keep adding oil until the oil level is in line with the MAX indicator.
4. Refit the oil fill plug.
5. Refit all dry pumping system side panels.

Figure 14 - Location of oil sight glass and fill plug on end cover

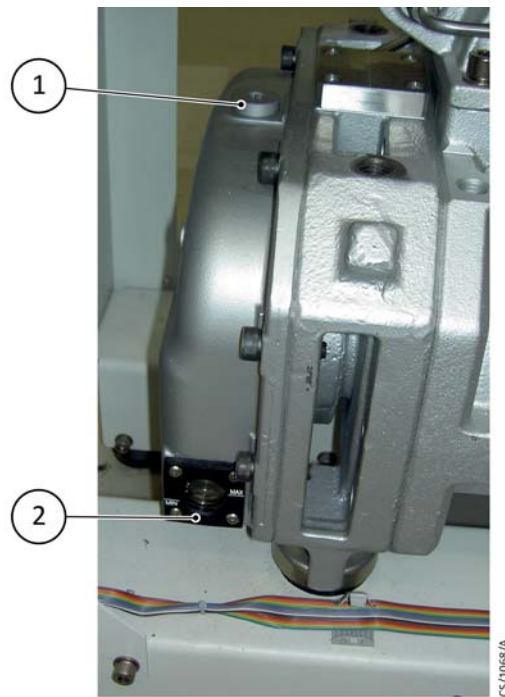

1. Oil filler plug
2. Oil sight glass

Figure 15 - Location of oil sight glass and fill plug on gearbox

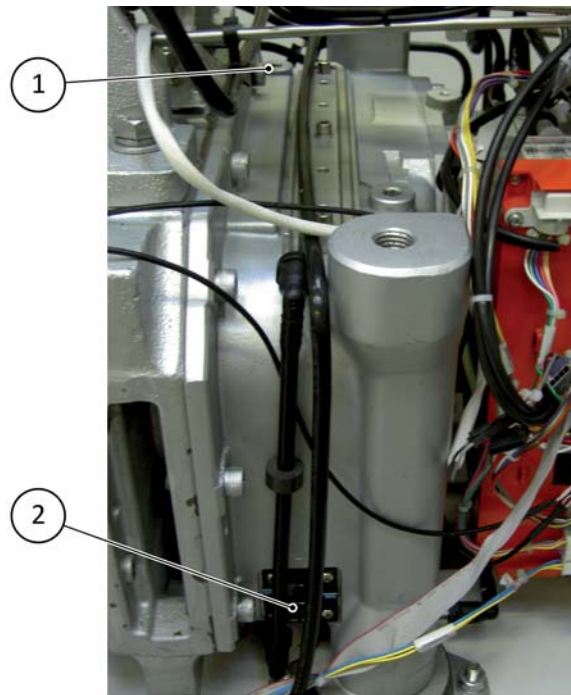

1. Oil filler plug
2. Oil sight glass

5.4.2 Inspect the connections, pipelines, cables and fittings

pending on the application, inspection and cleaning of the exhaust pipe and any elbows or check valves fitted may be needed. Contact Edwards for details and training. If the dry pumping system is not relocated for maintenance, ensure all supplies are locked out and tagged out before starting the following procedure.

1. Remove the enclosure side and top panels.
2. Check that all the connections are secure; tighten any loose connections. Inspect all cables, pipelines, hoses and connections and check that they are not corroded or damaged and do not leak; repair or replace any pipelines, hoses and connections that are corroded or damaged, or which leak.
3. Refit the enclosure side and top panels.

5.5 Overhaul



WARNING

Do not attempt to overhaul the pump without Edwards training and tooling.

Edwards provides a full range of overhaul options worldwide. Edwards can provide training, tooling and spares to enable users to overhaul their pumping systems. Contact Edwards for more information.

6 Transportation, storage and disposal

6.1 Transportation



WARNING

Do not drain the oil from the pump(s) whether dangerous substances have been pumped or not. Blanking plates must be fitted to seal all vacuum inlet and outlet ports (to prevent possible oil leakage). Ensure that the dry pumping system is correctly labelled, if in doubt contact Edwards.

Follow the procedure laid out in [Section 6.2](#) and then read form HS1 and fill out form HS2, which can be found at the back of this manual.

6.2 Storage

Drain the cooling water from the dry pumping system. If transporting or storing it in conditions where the cooling water could freeze, refer to [Section 5.3](#). Failure to observe the instructions could result in the cooling water freezing in the dry pumping system and damage to the pump(s) and/or the cooling water pipelines.

Store the dry pumping system as follows:

1. Follow the procedure set out in [Section 5.2](#).
2. Store the dry pumping system in clean dry conditions until required.
3. When required for use, prepare and install the dry pumping system as described in [Section 3](#) of this manual.

6.3 Disposal



WARNING

Dispose of the dry pumping system and any components safely and in accordance with all local and national safety and environmental requirements.

This equipment may contain a lithium manganese dioxide battery which, under California law, requires notification for the presence of perchlorate: Perchlorate Material - special handling may apply, refer to www.dtsc.ca.gov/hazardouswaste/perchlorate/

Edwards products are supported by a world-wide network of Edwards Service Centres. Each Service Centre offers a wide range of options including disposal. Refer to [Section 7.2](#) for more information.

Pump system materials suitable for recycling include cast SG iron, steel, PTFE, stainless steel, brass, aluminium, zinc alloy, nickel, mild steel, ABS, polyamide.

Take particular care with the following:

- Fluoroelastomers which may have decomposed as the result of being subjected to high temperatures.
- Components which have been contaminated with dangerous process substances.
- Lithium battery.

This page has been intentionally left blank.

7 Service, spares and accessories

7.1 Introduction



WARNING

When returning the dry pumping system to an Edwards Service Centre or other Edwards company, the requirements of [Section 7](#) and of the Return of Edwards Equipment Procedure (refer to forms HS1 and HS2 at the rear of this manual) must be complied with.

Note: The oil must not be drained from the dry pumping system. It must be clearly stated that the pump is full of oil when completing the HS2 form.

Edwards products, spares and accessories are available from Edwards companies and distributors world-wide. These centres employ Service Engineers who have undergone comprehensive Edwards training courses. Order spare parts and accessories from the nearest Edwards company or distributor. When ordering, please state for each part required:

1. Model and Item Number of the equipment.
2. Serial Number (if any).
3. Item Number and description of the part.

7.2 Service

Edwards products are supported by a world-wide network of Edwards Service Centres and distributors. Each Service Centre offers a wide range of options including: equipment decontamination; service exchange; repair; rebuild and testing to factory specifications. Equipment that has been serviced, repaired or rebuilt is returned with a full warranty. The local Service Centre can also provide Edwards engineers to support on-site maintenance, service or repair of the equipment. For more information about service options, contact the nearest Service Centre or other Edwards company.

Edwards can provide training, tooling and spares to enable users to overhaul their dry pumping systems.

Remove pump accessories before returning the dry pumping system for service.

7.3 Ordering accessories

Table 26 - Accessories

Description	Item Number
Exhaust check valve kit NW40 for GXS160 & 250 systems	A50782000
Exhaust check valve kit NW50 for GXS450 & 750 systems	A50790000
Water flow monitoring kit*	A50783000
Nitrogen flow switches:	
Suitable for 0 - 60 slm	A50633000
Suitable for 0 - 204 slm	A50634000
PDT	D37280700
MCM MicroTIM	D37360320
Connector kit for MCM MicroTIM	D37422802
Virtual Display Terminal (VPDT)	D37488500
Accessory modules:	
Active Accessory Module (AAM)†	D37480500
Passive Accessory Module (PAM)†	D37480550
GXS AAM/PAM bracket kit†	Contact Edwards
Adaptor cable 5 way XLR to 9 way D type, 2 m long	D37370754
Profibus module kit	D39753000
Pressure indicator assembly	M58808141
GXS auxiliary gauge cable (0 - 10 V)	D37241017
GXS pressure input cable (4 - 20 mA)	D37241019
Connector kit for 4 - 20 mA cable	D37241023
Inlet isolation valve (with position indicator)	Contact Edwards
Inlet spool	Contact Edwards
Inlet filter	Contact Edwards
Inlet knock-out pot	Contact Edwards
Exhaust knock-out pot	Contact Edwards
Cleanable, drainable silencer	Contact Edwards
Instrument pack (PT100 & ASG + cables)	Contact Edwards

* Only suitable for GXS160 and GXS250 dry pumping systems.

† AAM includes a PAM. Note that the GXS AAM/PAM bracket kit is required to fit AAM/PAM to the pump.

7.4 Spares

Table 27 - Spares

Spare	Item Number
Drynert 25/6 lubricant:	
1 kg (529 ml)	H11312021
5 kg (2646 ml)	H11312025

For information about all other spares, refer to the customer parts manual M588-40-845.

Appendix A1 Installation drawings

A1.1 GXS160

Figure A1 - GXS160 installation drawing (Sheet 1)

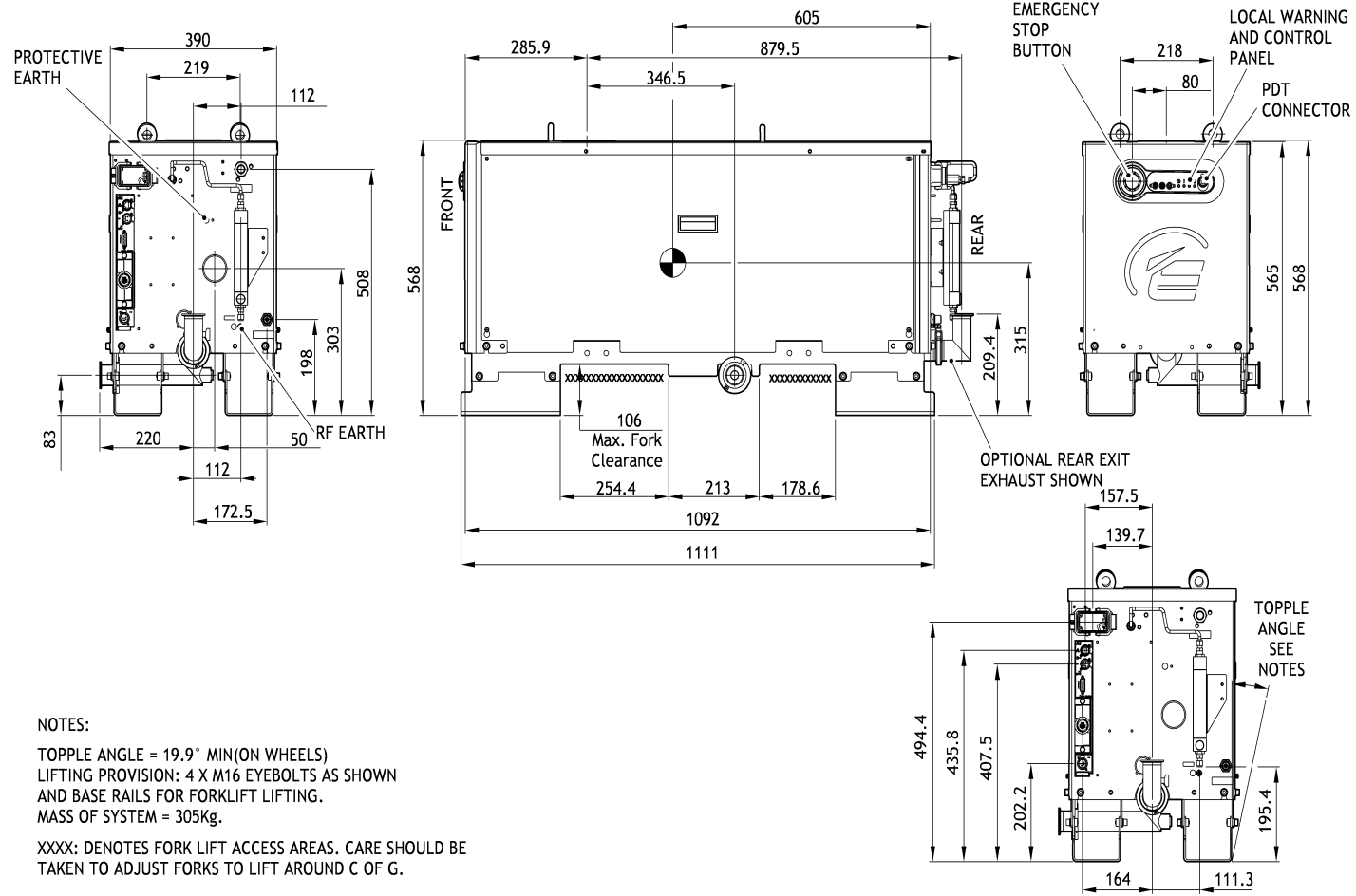

NOTES:

TOPPLE ANGLE = 19.9° MIN(ON WHEELS)
 LIFTING PROVISION: 4 X M16 EYEBOLTS AS SHOWN
 AND BASE RAILS FOR FORKLIFT LIFTING.
 MASS OF SYSTEM = 305Kg.

XXXX: DENOTES FORK LIFT ACCESS AREAS. CARE SHOULD BE
 TAKEN TO ADJUST FORKS TO LIFT AROUND C OF G.

GXS 160 ins 1

dcs/8491/001



Figure A2 - GXS160 installation drawing (Sheet 2)

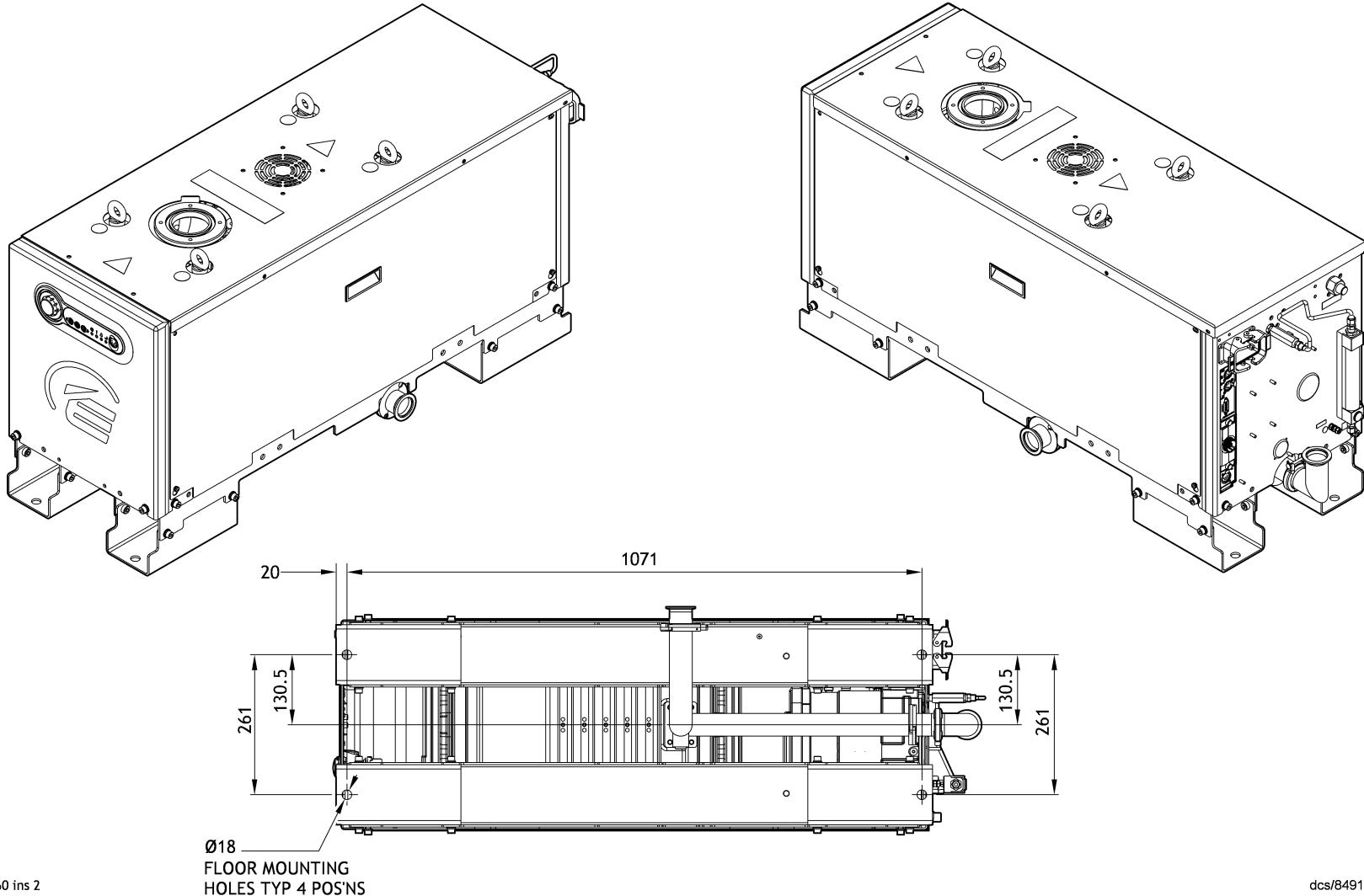

GXS 160 ins 2

dcS/8491/005

Figure A3 - GXS160 installation drawing (Sheet 3)

IMAGES SHOWN WITH OPTIONAL CASTOR ASSEMBLIES

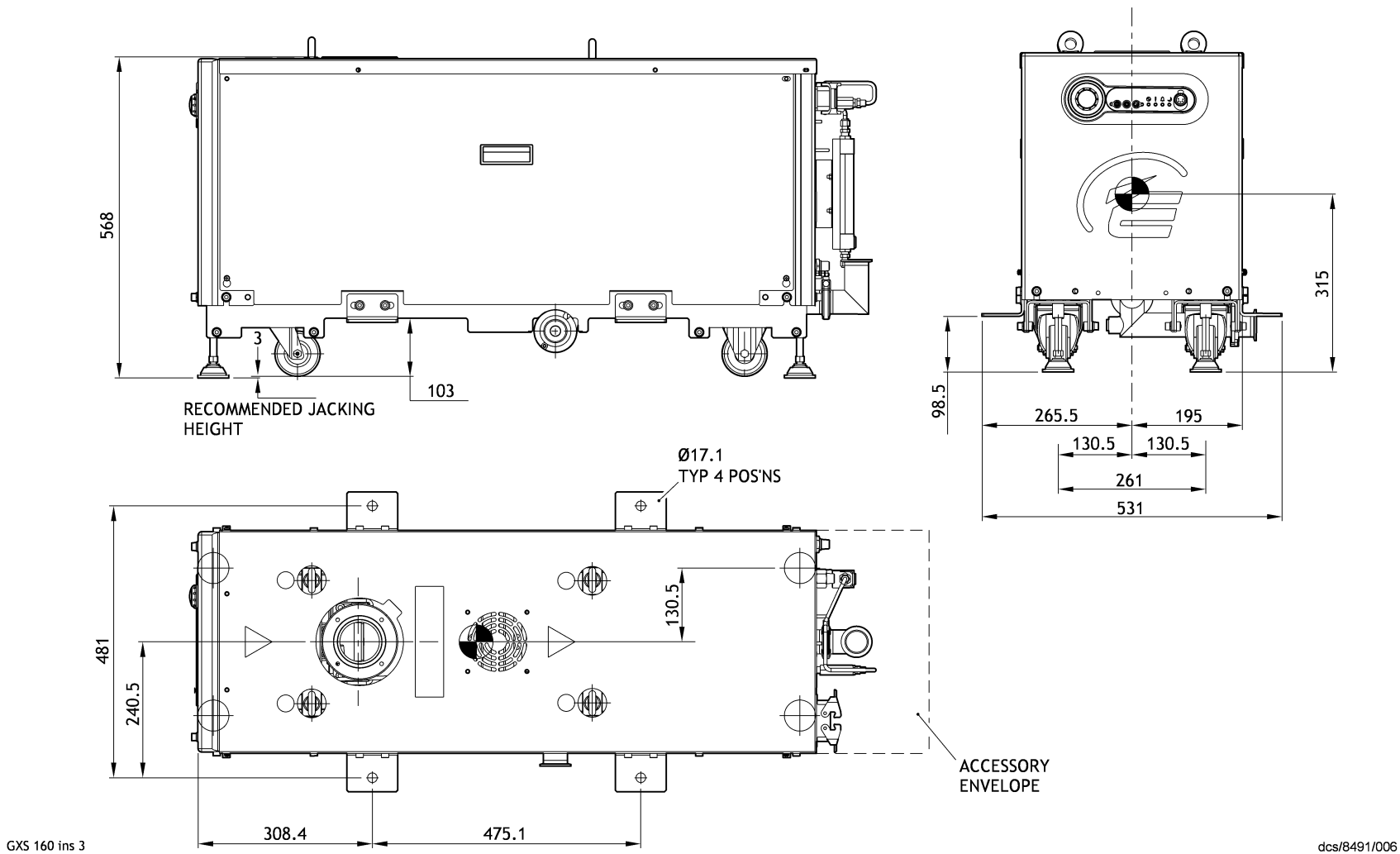
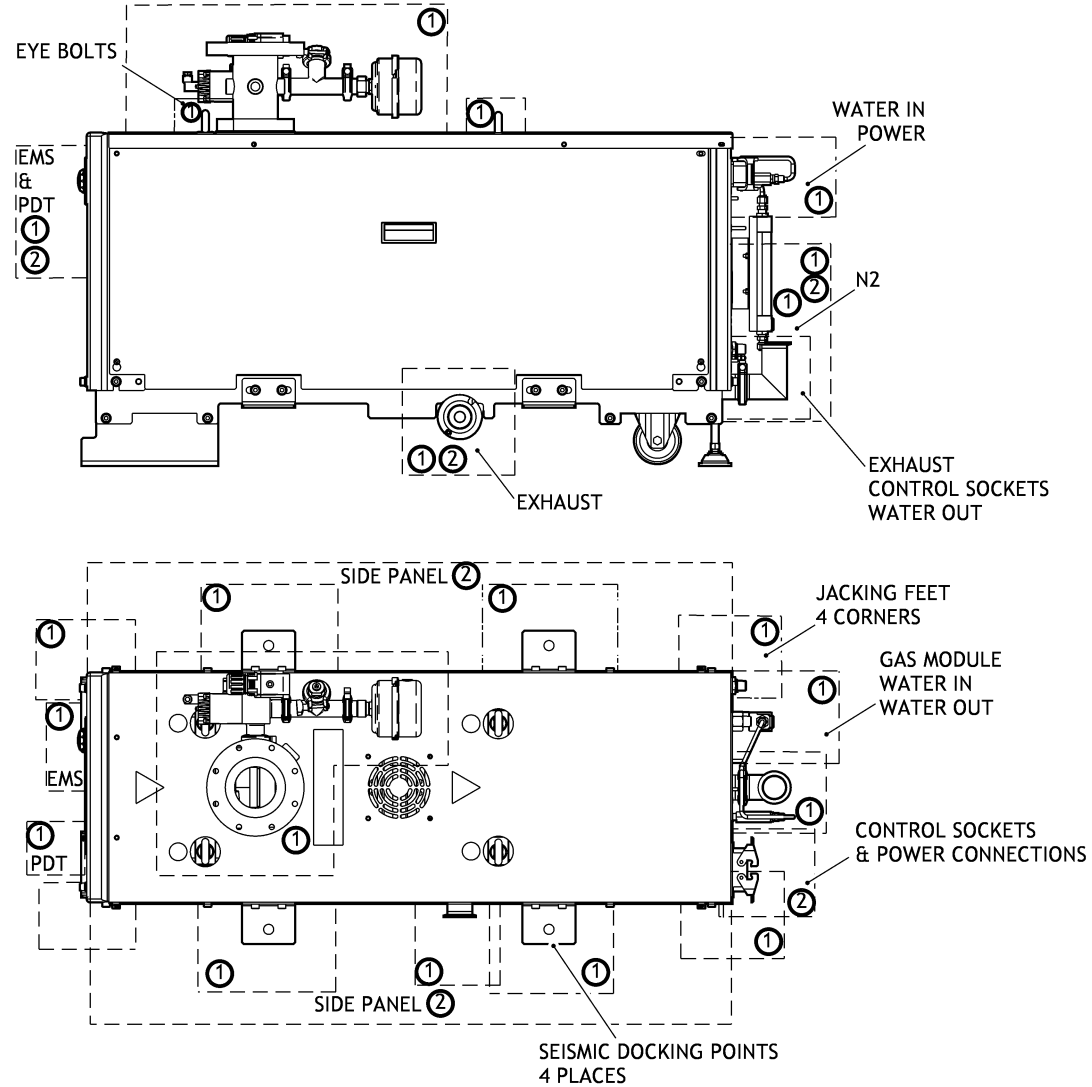

Figure A4 - GXS160 installation drawing (Sheet 4)

VIEWS SHOWN WITH ALL STANDARD ACCESSORIES THAT PROTRUDE OUTSIDE OF THE GENERAL PUMP ENVELOPE AND THESE ARE REPRESENTED IN DASHED LINES.
 CASTOR ASSEMBLY SHOWN AT REAR AND FLOOR MOUNT PLATES SHOWN AT THE FRONT TO DISPLAY BOTH OPTIONS



NOTES:
 ACCESS SHOWN AS GUIDANCE ONLY.

- ① RECOMMENDED ACCESS
- ② RECOMMENDED SERVICE ACCESS

GXS 160 ins 4

dcs/8491/007

A1.2 GXS160/1750

Figure A5 - GXS160/1750 installation drawing (Sheet 1)

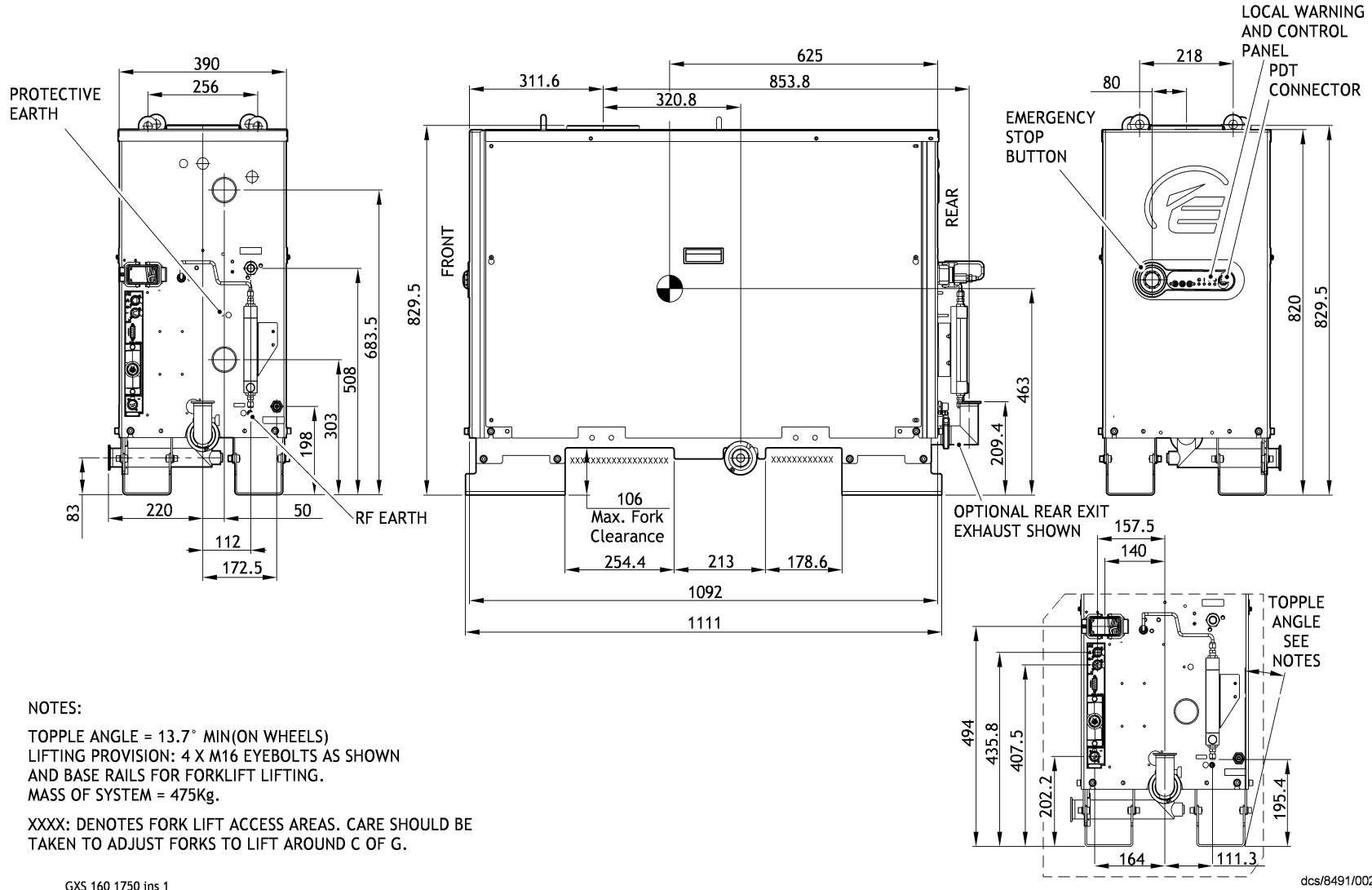

GXS 160 1750 ins 1



Figure A6 - GXS160/1750 installation drawing (Sheet 2)

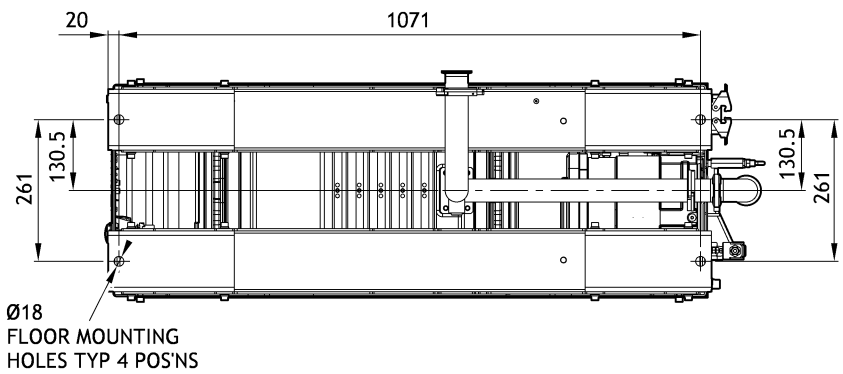
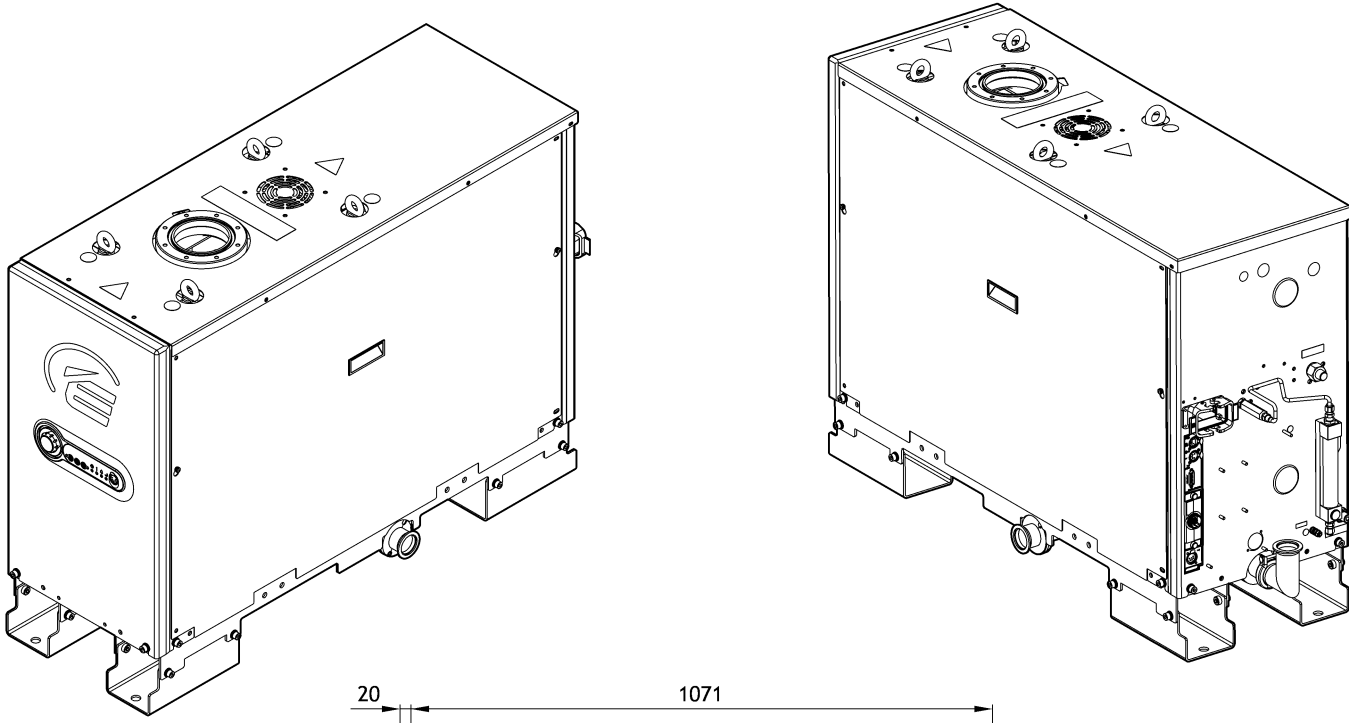

GXS 160 1750 ins 2

dcs/8491/008

Figure A7 - GXS160/1750 installation drawing (Sheet 3)

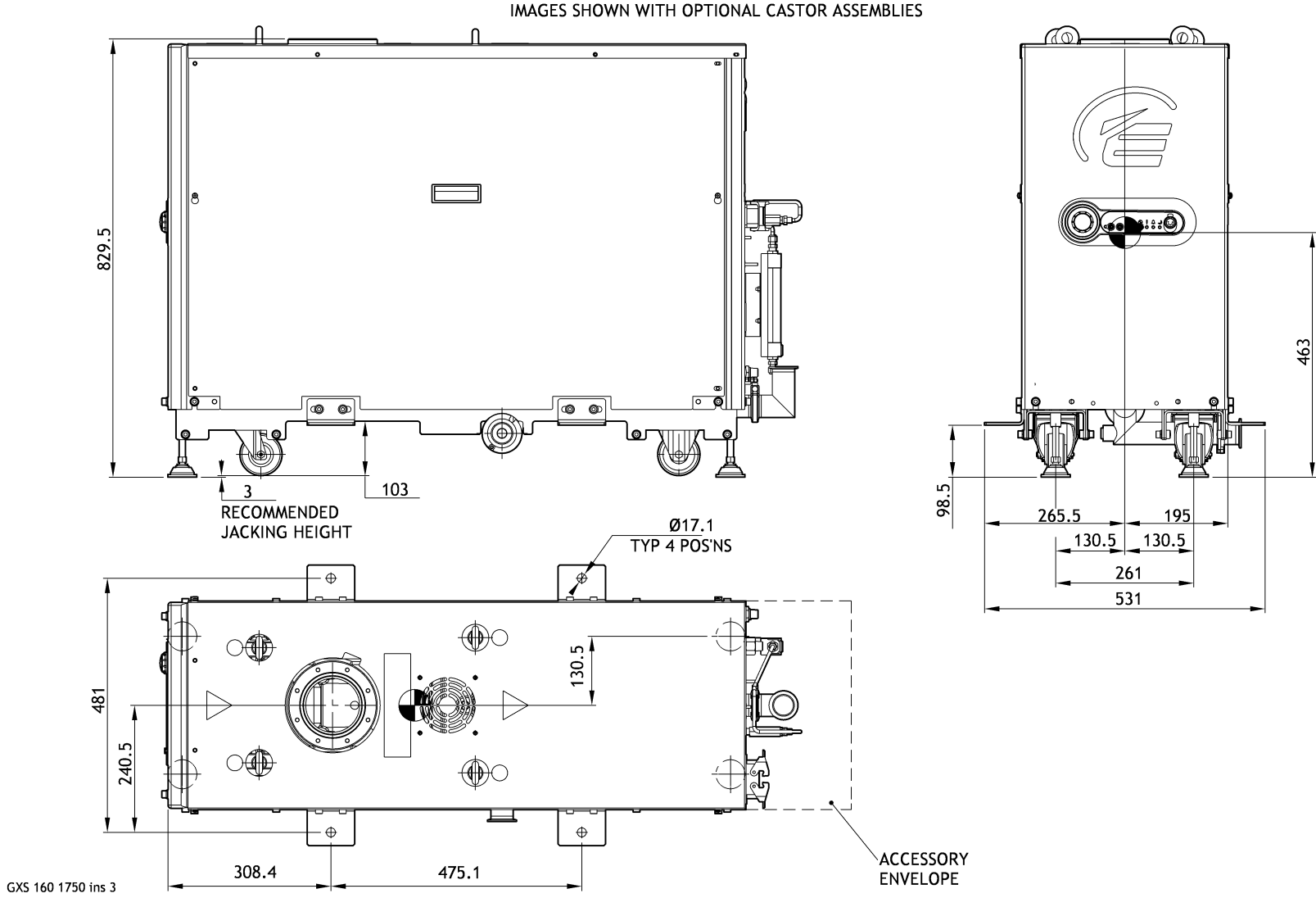
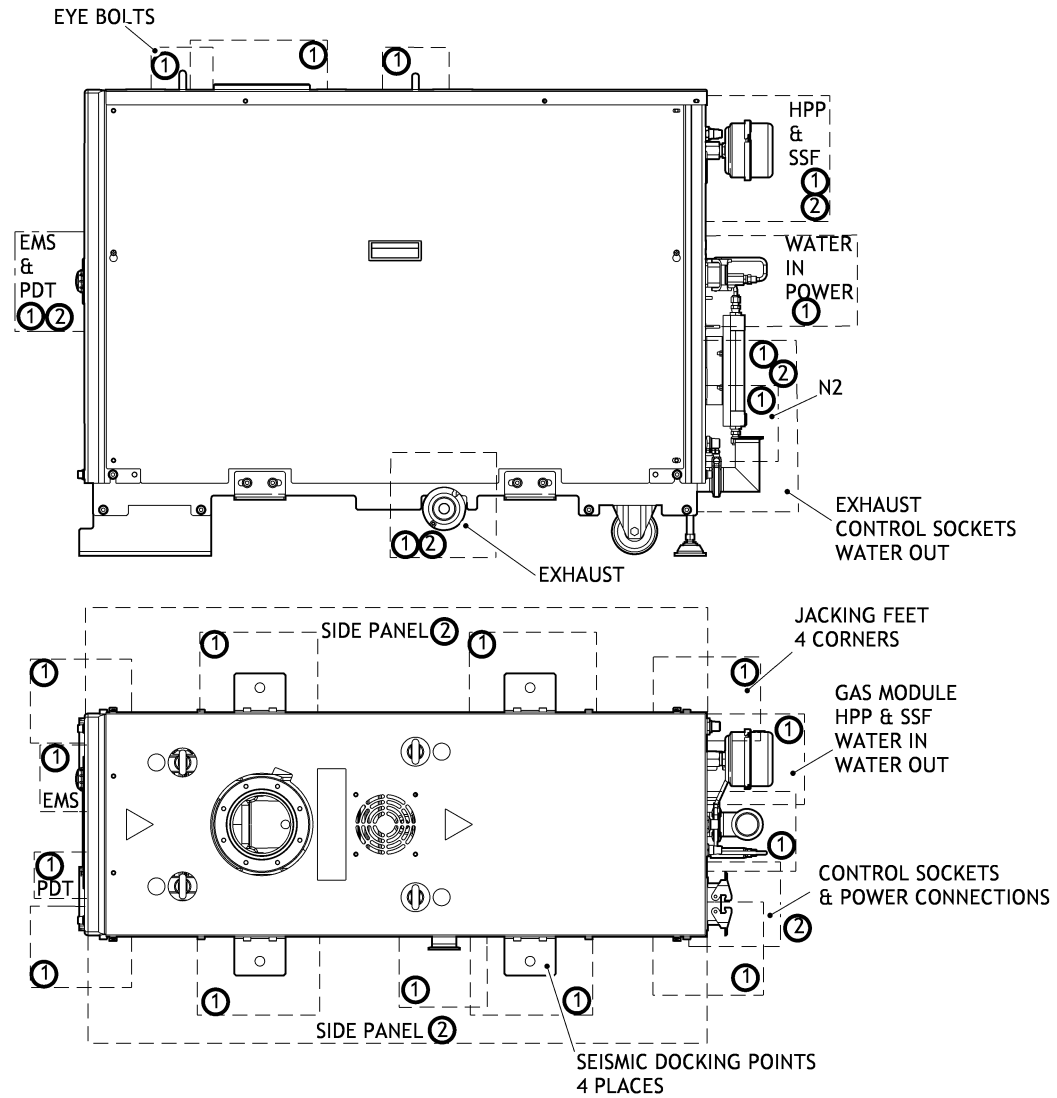

Figure A8 - GXS160/1750 installation drawing (Sheet 4)

VIEWS SHOWN WITH ALL STANDARD ACCESSORIES THAT PROTRUDE OUTSIDE OF THE GENERAL PUMP ENVELOPE AND THESE ARE REPRESENTED IN DASHED LINES.
 CASTOR ASSEMBLY SHOWN AT REAR AND FLOOR MOUNT PLATES SHOWN AT THE FRONT TO DISPLAY BOTH OPTIONS



NOTES:
 ACCESS SHOWN AS GUIDANCE ONLY.

- ① RECOMMENDED ACCESS
- ② RECOMMENDED SERVICE ACCESS

GXS 160 1750 ins 4

dcs/8491/010

A1.3 GXS250

Figure A9 - GXS250 installation drawing (Sheet 1)

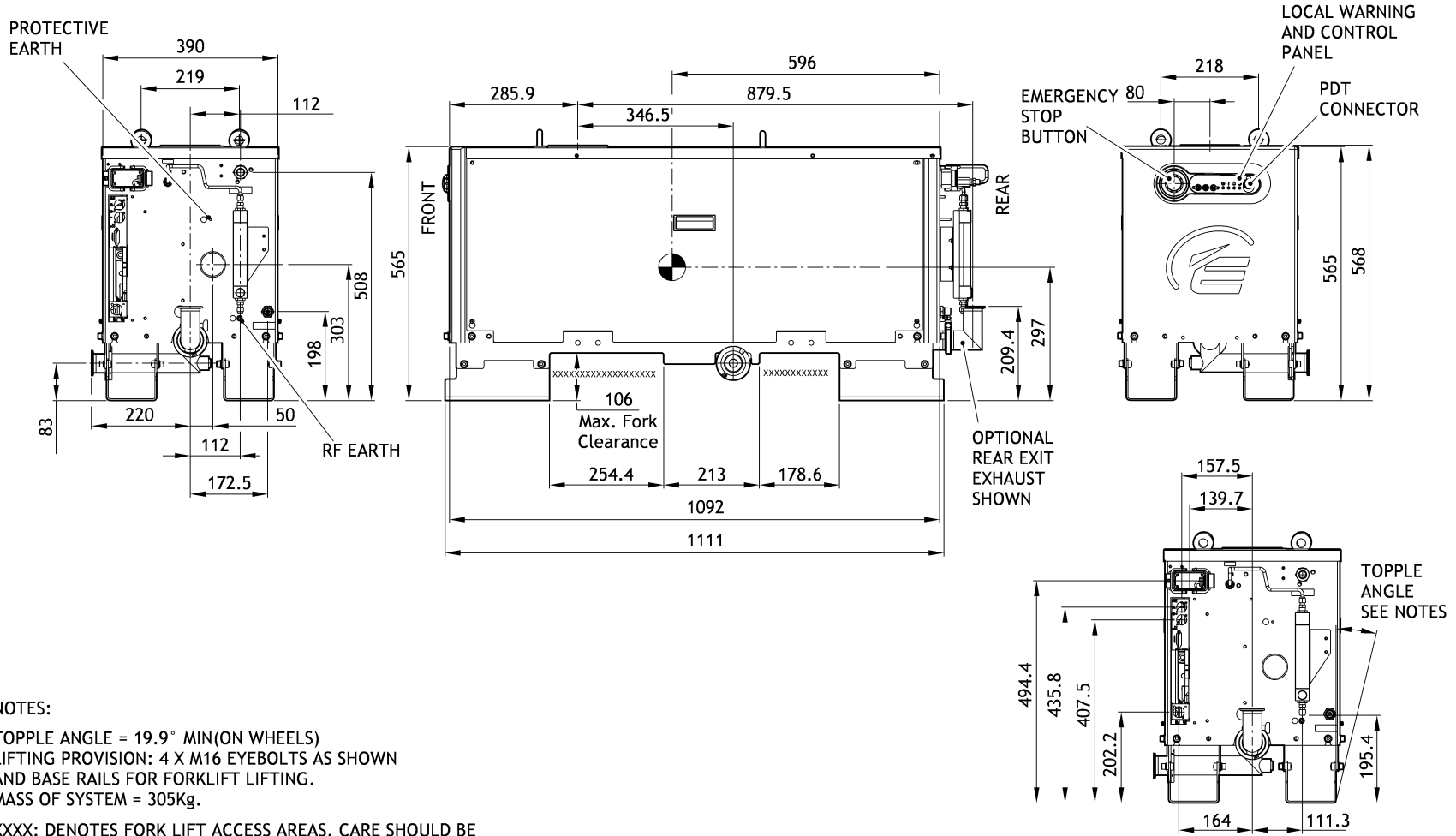

NOTES:

TOPPLE ANGLE = 19.9° MIN(ON WHEELS)
 LIFTING PROVISION: 4 X M16 EYEBOLTS AS SHOWN
 AND BASE RAILS FOR FORKLIFT LIFTING.
 MASS OF SYSTEM = 305Kg.

XXXX: DENOTES FORK LIFT ACCESS AREAS. CARE SHOULD BE
 TAKEN TO ADJUST FORKS TO LIFT AROUND C OF G.

GXS 250 inst 1

dcs/8491/003



Figure A10 - GXS250 installation drawing (Sheet 2)

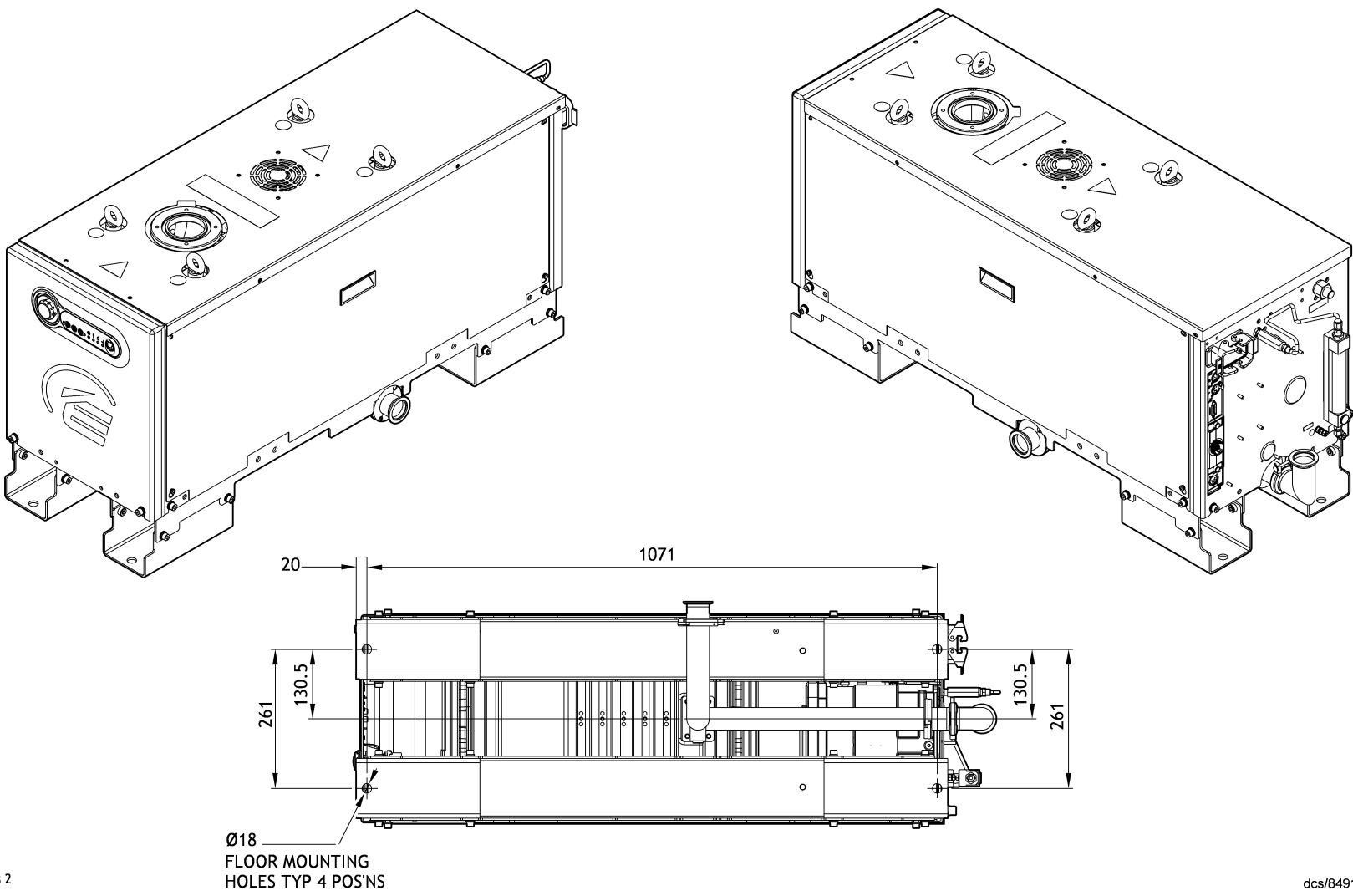

GXS 250 ins 2

dcs/8491/011

Figure A11 - GXS250 installation drawing (Sheet 3)

IMAGES SHOWN WITH OPTIONAL CASTOR ASSEMBLIES

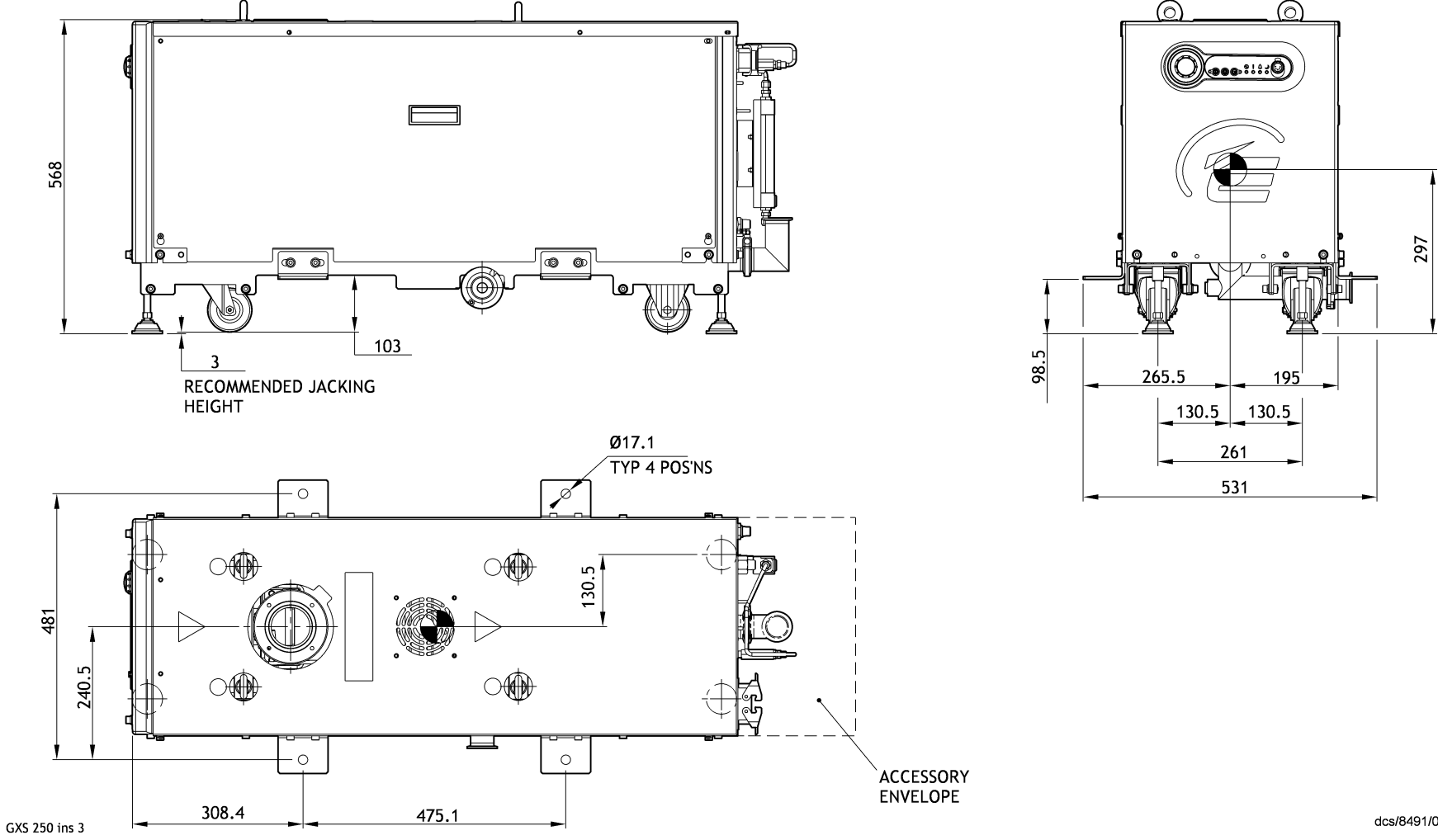
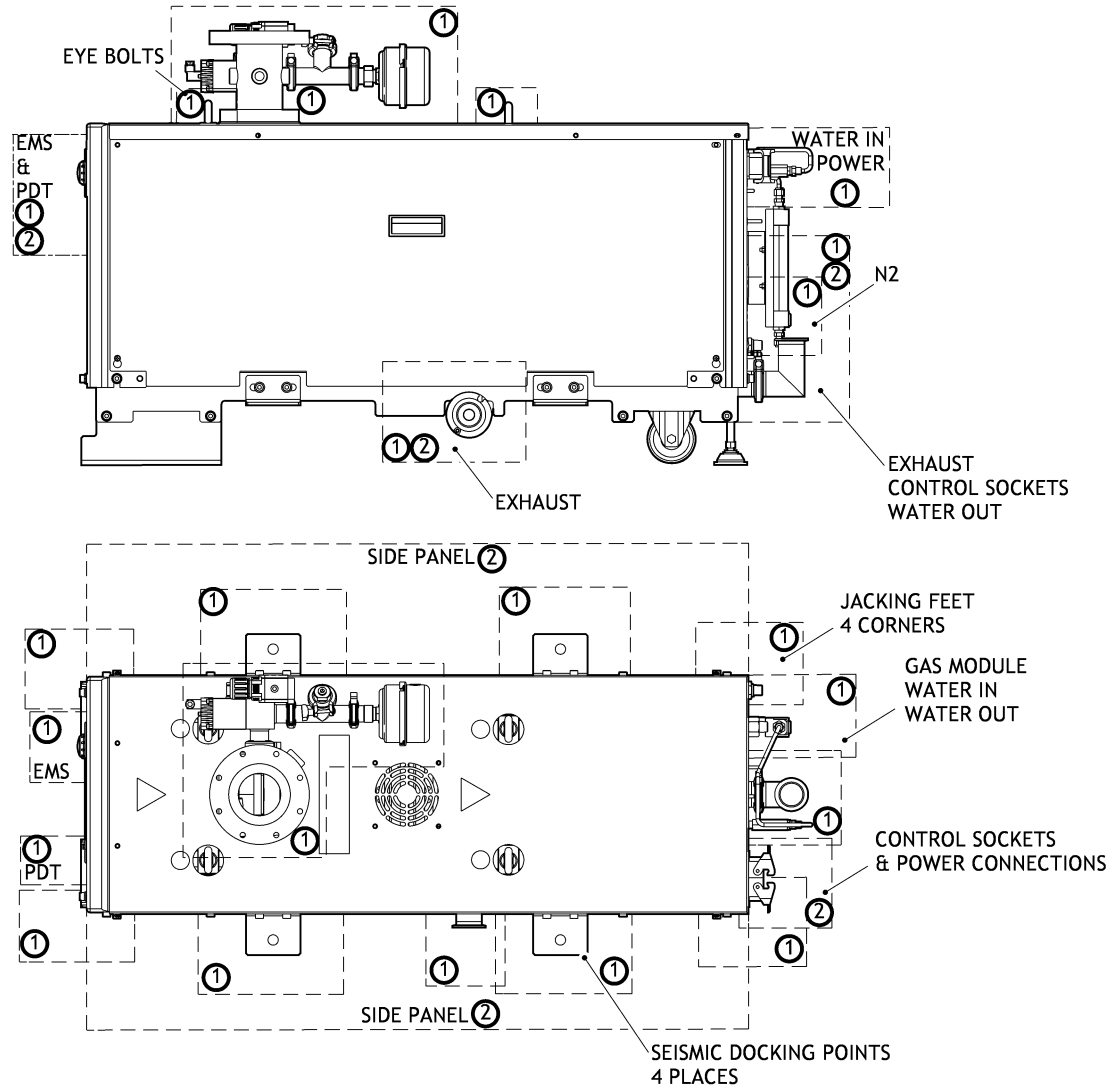

Figure A12 - GXS250 installation drawing (Sheet 4)

VIEWS SHOWN WITH ALL STANDARD ACCESSORIES THAT PROTRUDE OUTSIDE OF THE GENERAL PUMP ENVELOPE AND THESE ARE REPRESENTED IN DASHED LINES.
 CASTOR ASSEMBLY SHOWN AT REAR AND FLOOR MOUNT PLATES SHOWN AT THE FRONT TO DISPLAY BOTH OPTIONS



NOTES:
 ACCESS SHOWN AS GUIDANCE ONLY.

- ① RECOMMENDED ACCESS
- ② RECOMMENDED SERVICE ACCESS

GXS 250 ins 4

dc8/B491/013

A1.4 GXS250/2600

Figure A13 - GXS250/2600 installation drawing (Sheet 1)

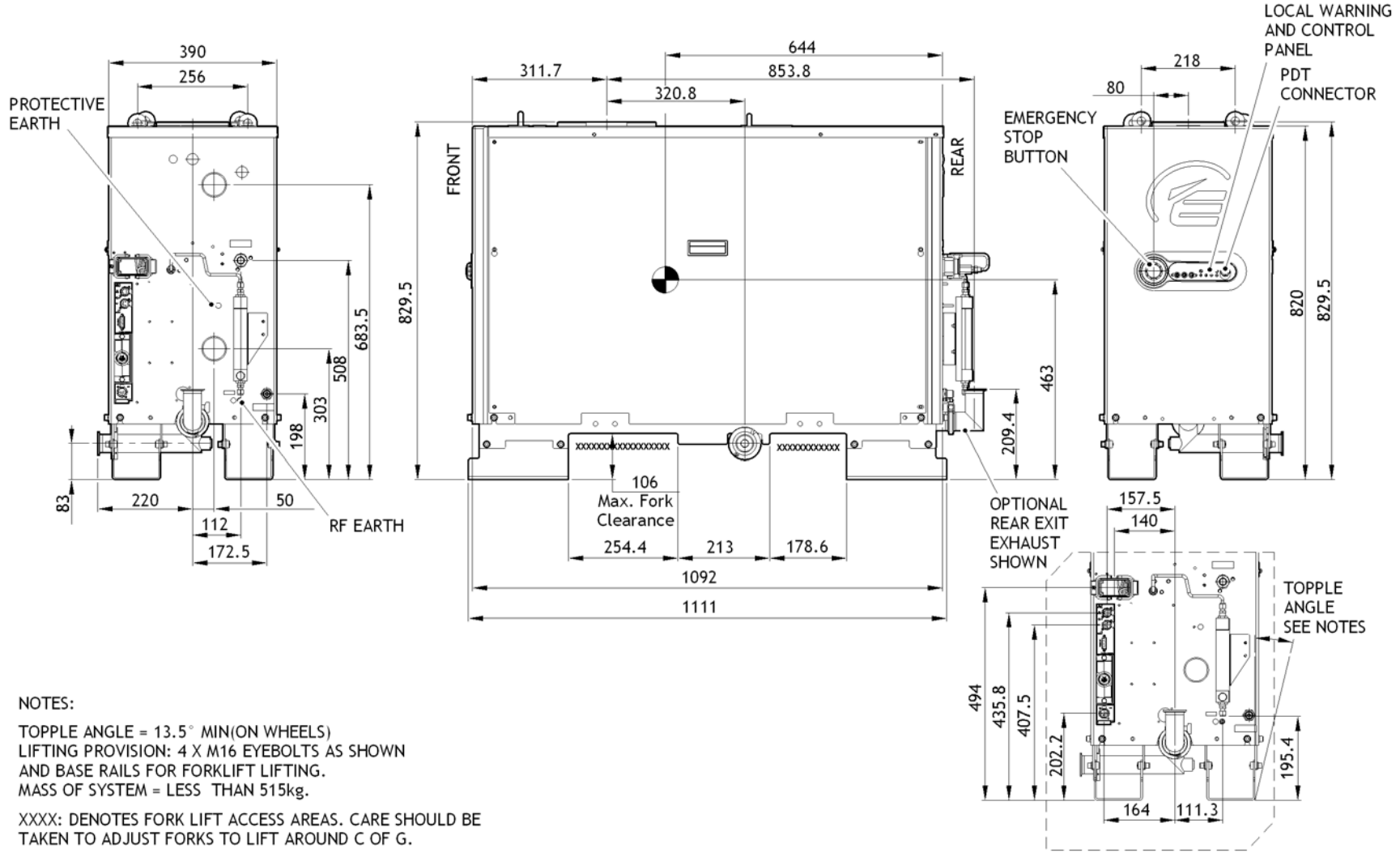

NOTES:

TOPPLE ANGLE = 13.5° MIN(ON WHEELS)
 LIFTING PROVISION: 4 X M16 EYEBOLTS AS SHOWN
 AND BASE RAILS FOR FORKLIFT LIFTING.
 MASS OF SYSTEM = LESS THAN 515kg.

XXXX: DENOTES FORK LIFT ACCESS AREAS. CARE SHOULD BE
 TAKEN TO ADJUST FORKS TO LIFT AROUND C OF G.

GXS 250-2600 ins 1

dcs/8491/004

Figure A14 - GXS250/2600 installation drawing (Sheet 2)

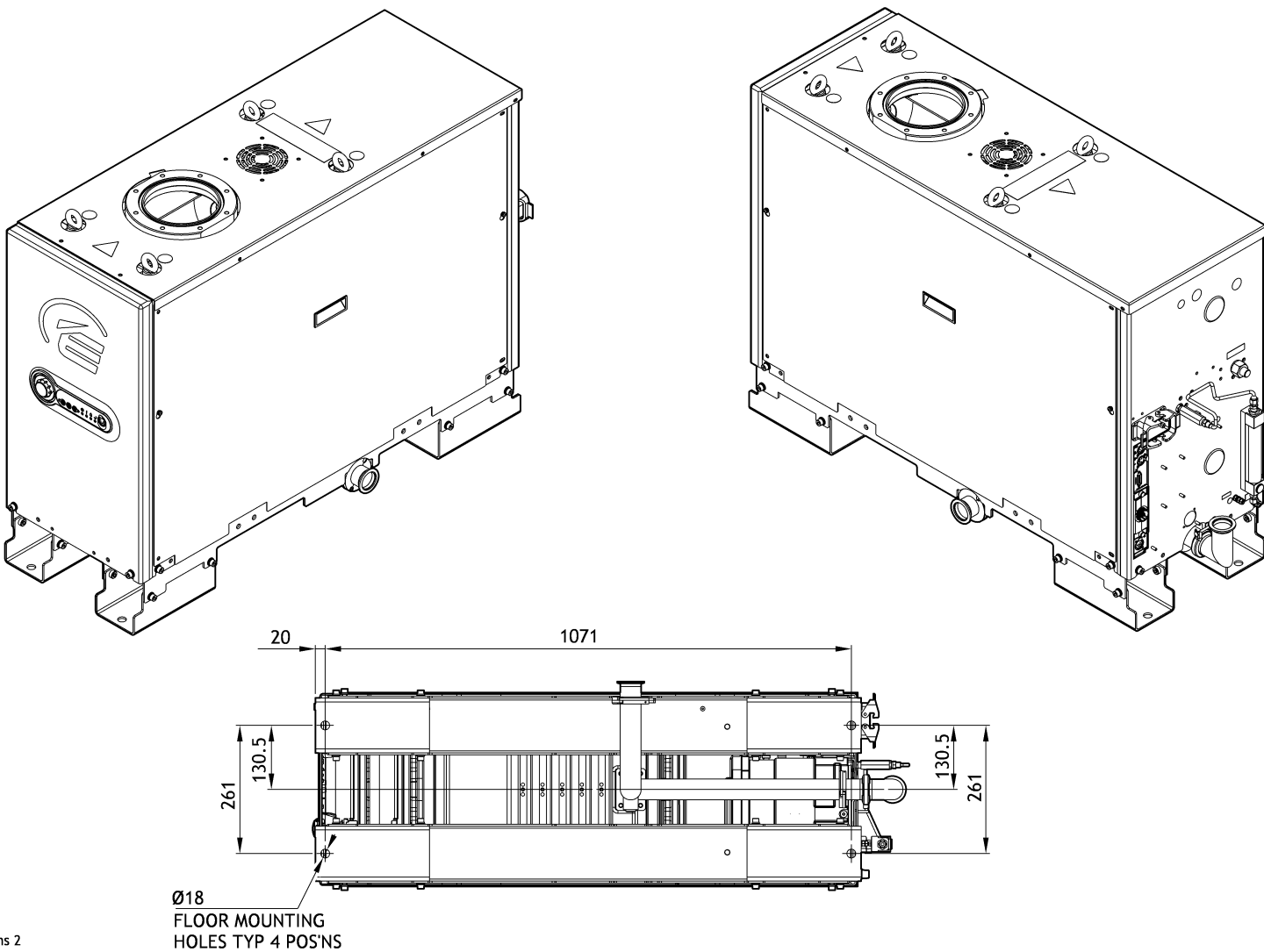

GXS 250-2600 ins 2

dcs/8491/014

Figure A15 - GXS250/2600 installation drawing (Sheet 3)

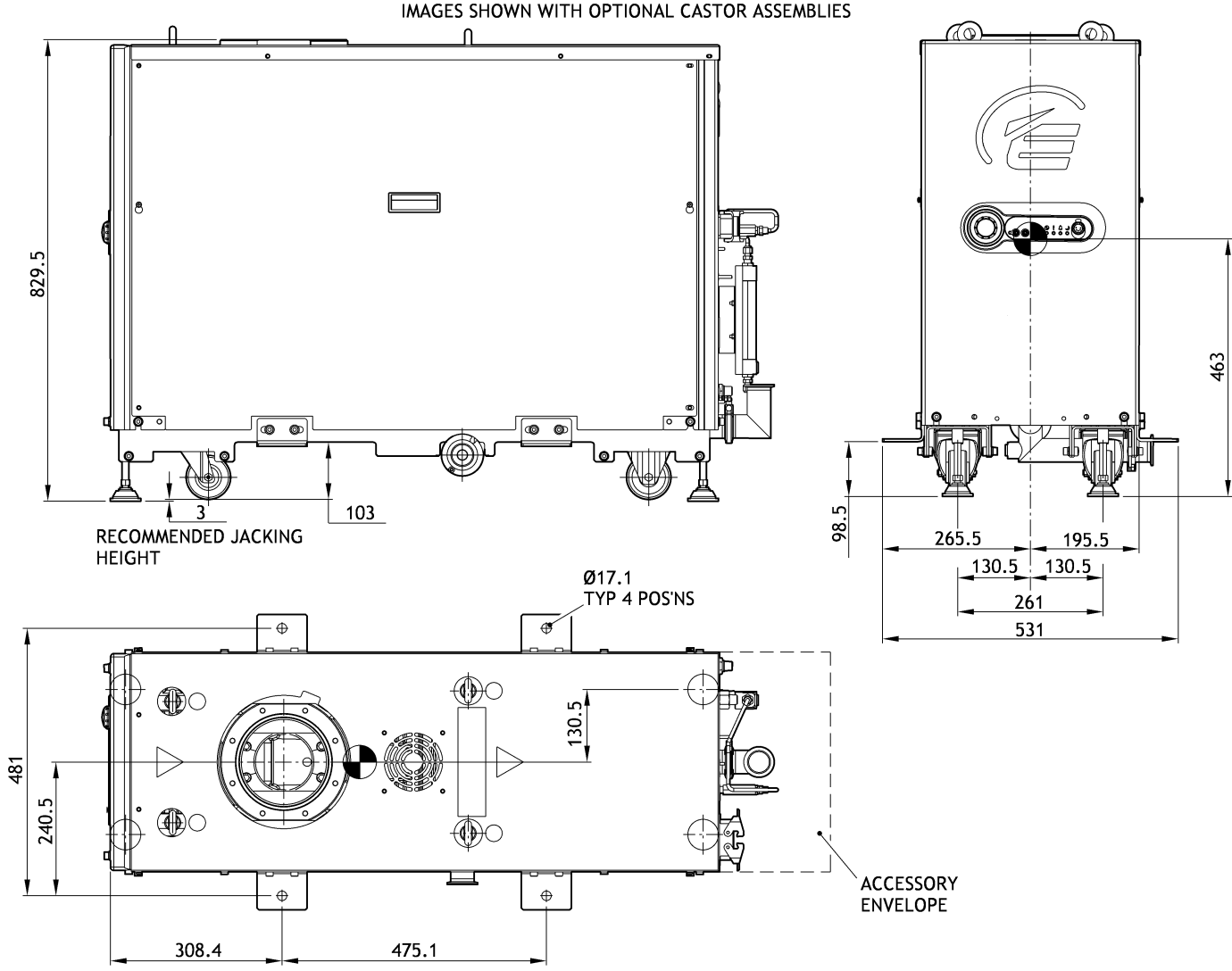

dcs/8491/016

GXS 250-2600 ins 3

Figure A16 - GXS250/2600 installation drawing (Sheet 4)

VIEWS SHOWN WITH ALL STANDARD ACCESSORIES THAT PROTRUDE OUTSIDE OF THE GENERAL PUMP ENVELOPE AND THESE ARE REPRESENTED IN DASHED LINES.
 CASTOR ASSEMBLY SHOWN AT REAR AND FLOOR MOUNT PLATES SHOWN AT THE FRONT TO DISPLAY BOTH OPTIONS.

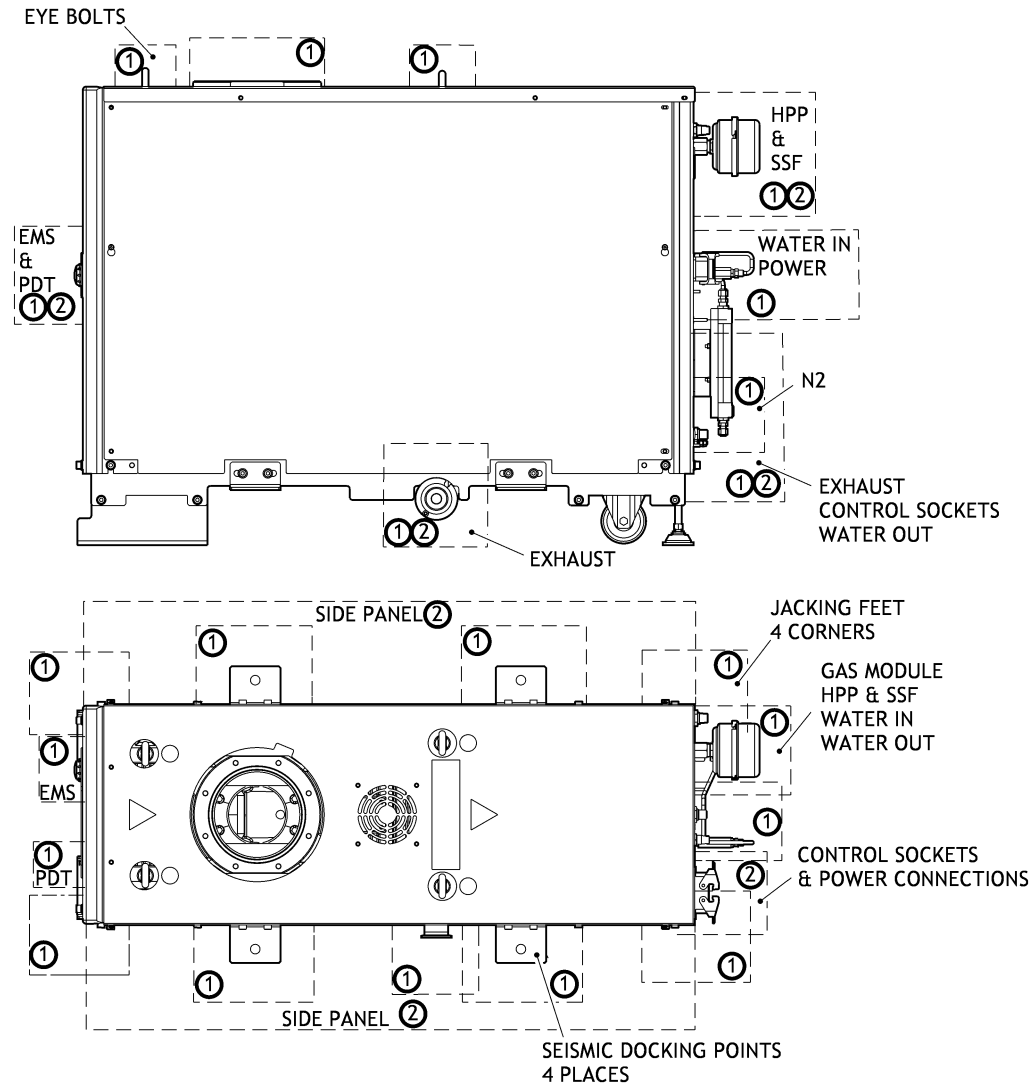

NOTES:
 ACCESS SHOWN AS GUIDANCE ONLY.

- ① RECOMMENDED ACCESS
- ② RECOMMENDED SERVICE ACCESS

GXS 250-2600 ins 4

dc8/8491/015

A1.5 GXS450

Figure A17 - GXS450 installation drawing (Sheet 1)

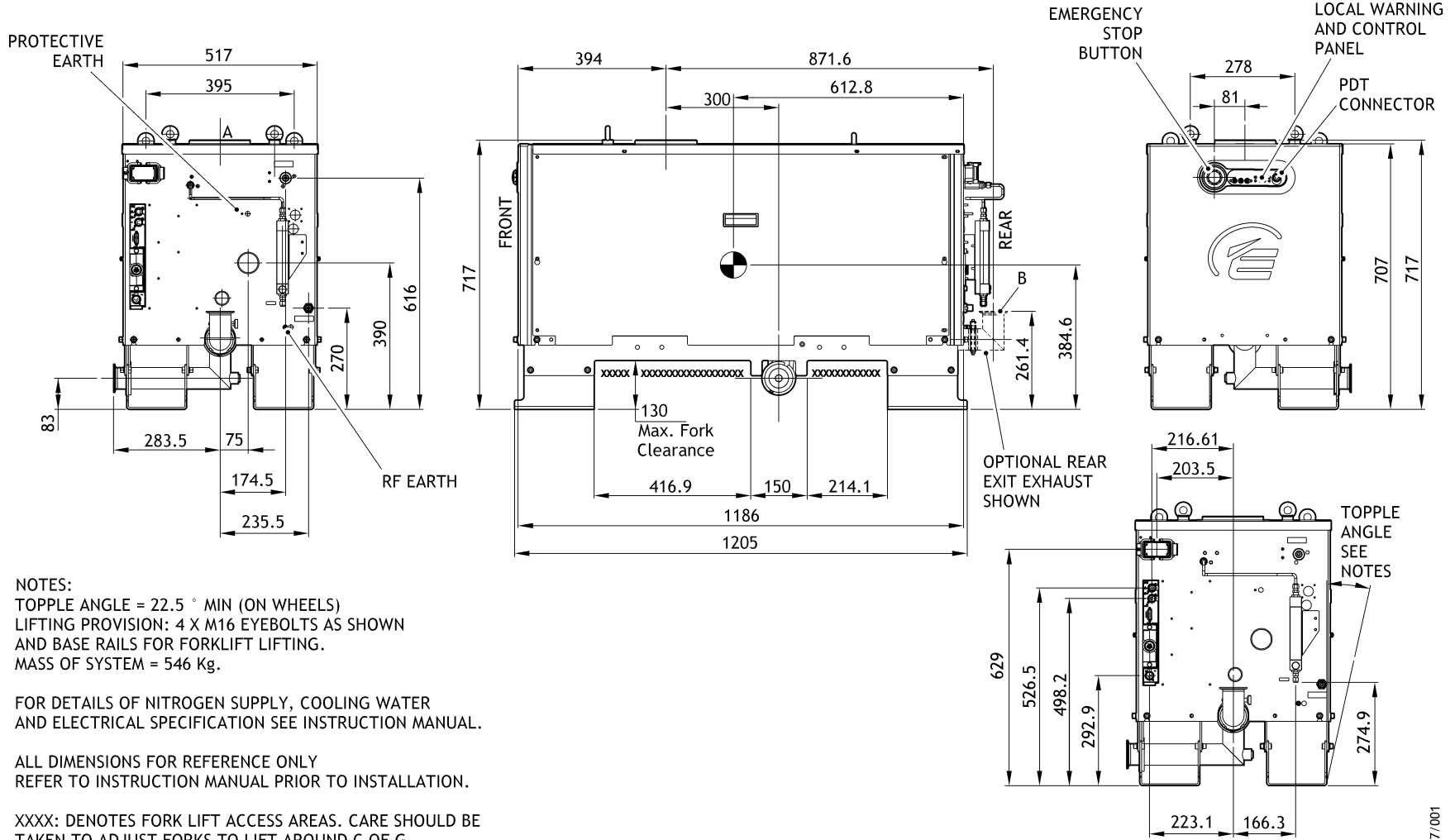

NOTES:
 TOPPLE ANGLE = 22.5 ° MIN (ON WHEELS)
 LIFTING PROVISION: 4 X M16 EYEBOLTS AS SHOWN
 AND BASE RAILS FOR FORKLIFT LIFTING.
 MASS OF SYSTEM = 546 Kg.

FOR DETAILS OF NITROGEN SUPPLY, COOLING WATER
 AND ELECTRICAL SPECIFICATION SEE INSTRUCTION MANUAL.

ALL DIMENSIONS FOR REFERENCE ONLY
 REFER TO INSTRUCTION MANUAL PRIOR TO INSTALLATION.

XXXX: DENOTES FORK LIFT ACCESS AREAS. CARE SHOULD BE
 TAKEN TO ADJUST FORKS TO LIFT AROUND C OF G.

GXS 450 ins 1

dcsl/8897/001

Figure A18 - GXS450 installation drawing (Sheet 2)

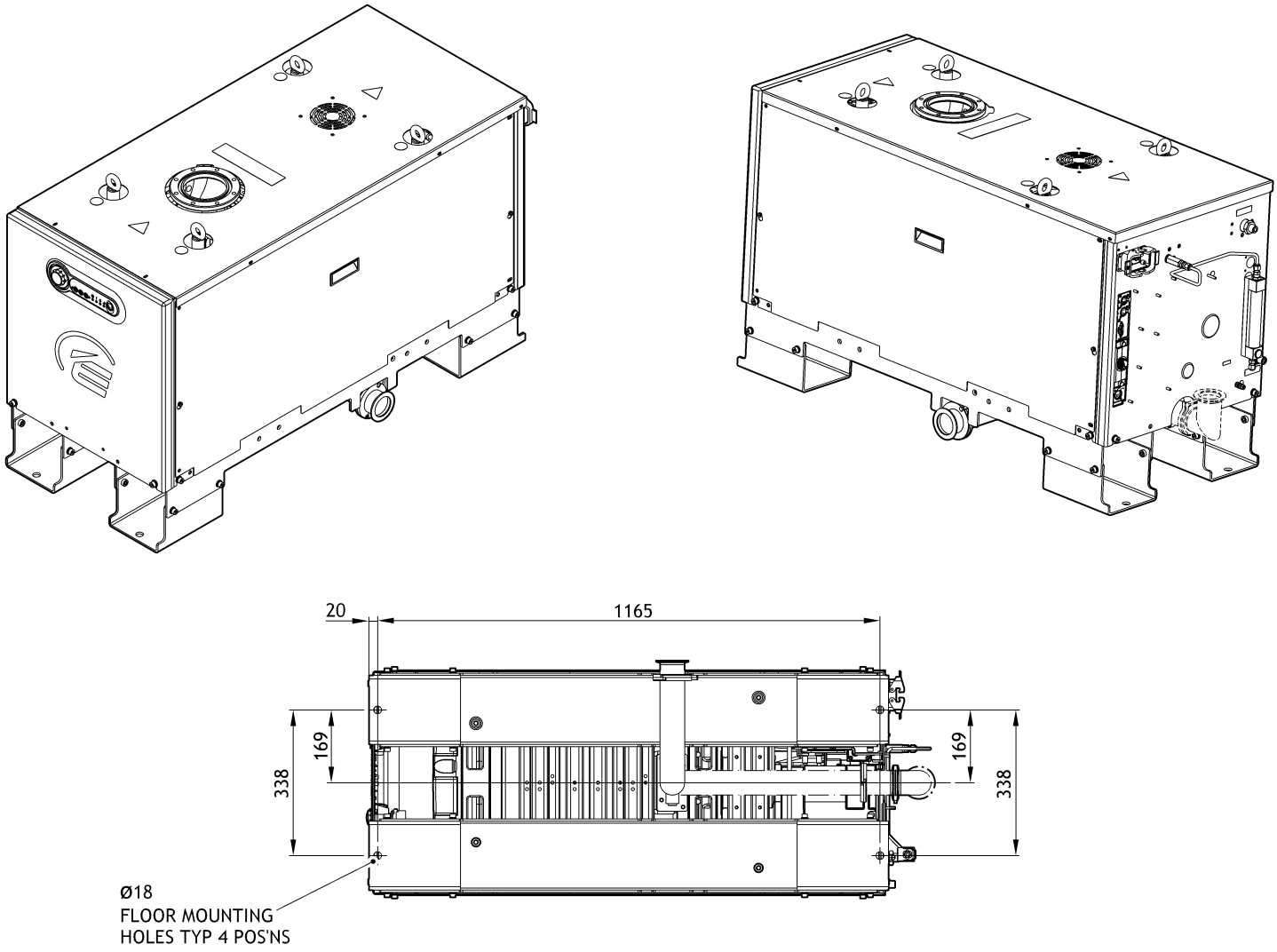

GXS 450 ins 2

dcs/8897/003

Figure A19 - GXS450 installation drawing (Sheet 3)

IMAGES SHOWN WITH OPTIONAL CASTOR AND REAR EXIT EXHAUST ASSEMBLIES

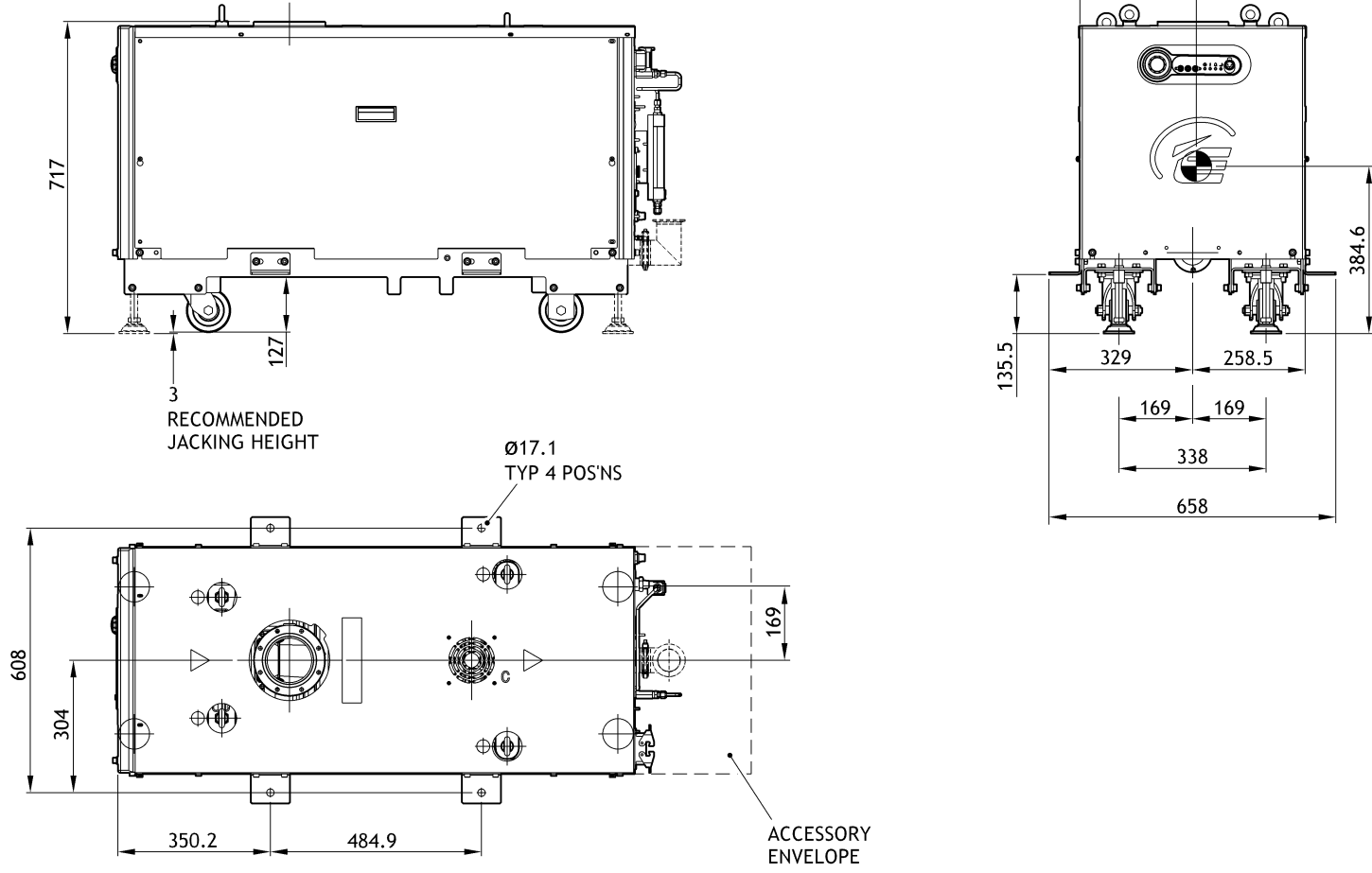

GXS 450 ins 3

Figure A20 - GXS450 installation drawing (Sheet 4)

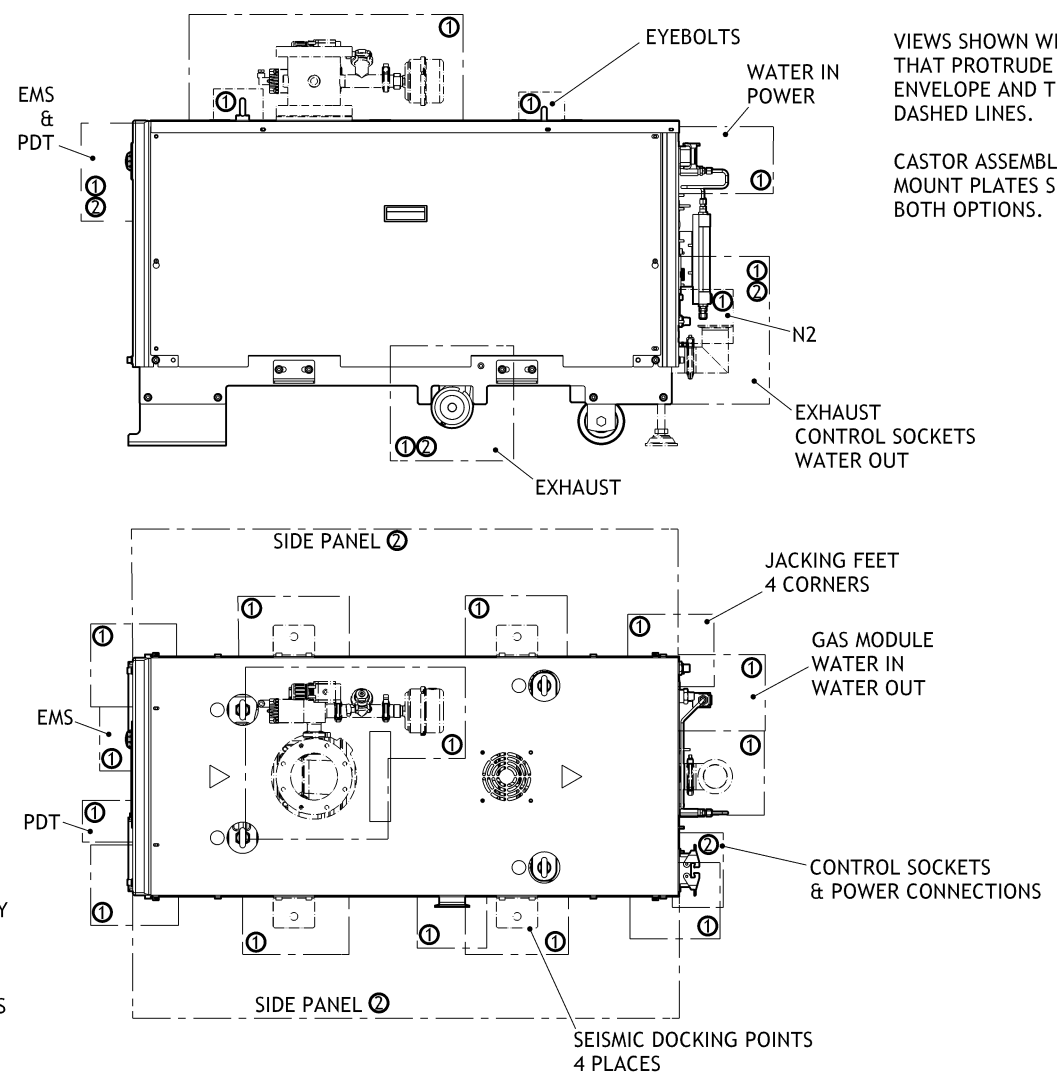

VIEWS SHOWN WITH ALL STANDARD ACCESSORIES THAT PROTRUDE OUTSIDE OF THE GENERAL PUMP ENVELOPE AND THESE ARE REPRESENTED IN DASHED LINES.

CASTOR ASSEMBLY SHOWN AT REAR AND FLOOR MOUNT PLATES SHOWN AT THE FRONT TO DISPLAY BOTH OPTIONS.

- NOTES :
- ACCESS SHOWN AS GUIDANCE ONLY
 - ① RECOMMENDED ACCESS
 - ② RECOMMENDED SERVICE ACCESS

GXS 450 ins 4

dcsl/8897/004



A1.6 GXS450/2600

Figure A21 - GXS450/2600 installation drawing (Sheet 1)

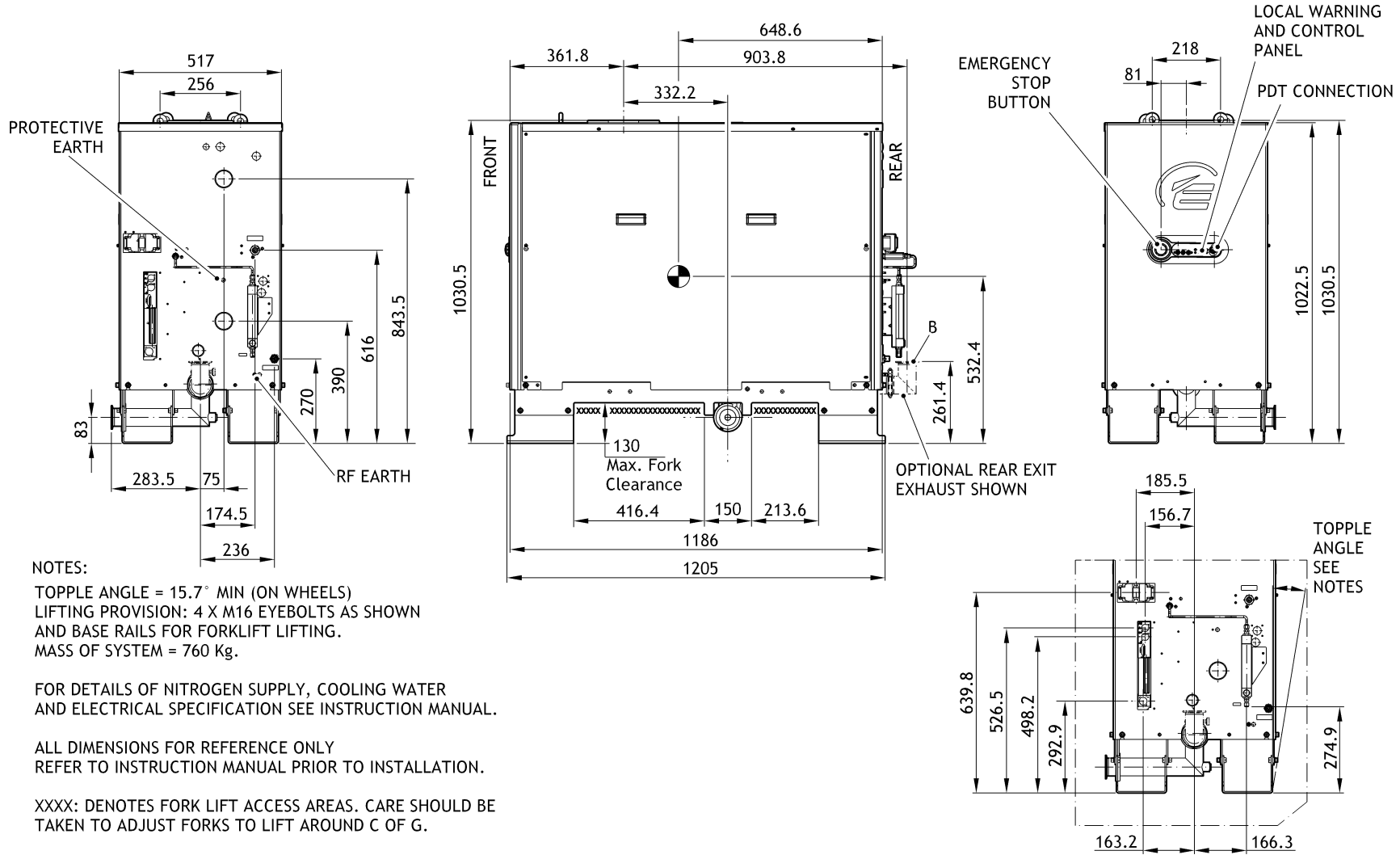
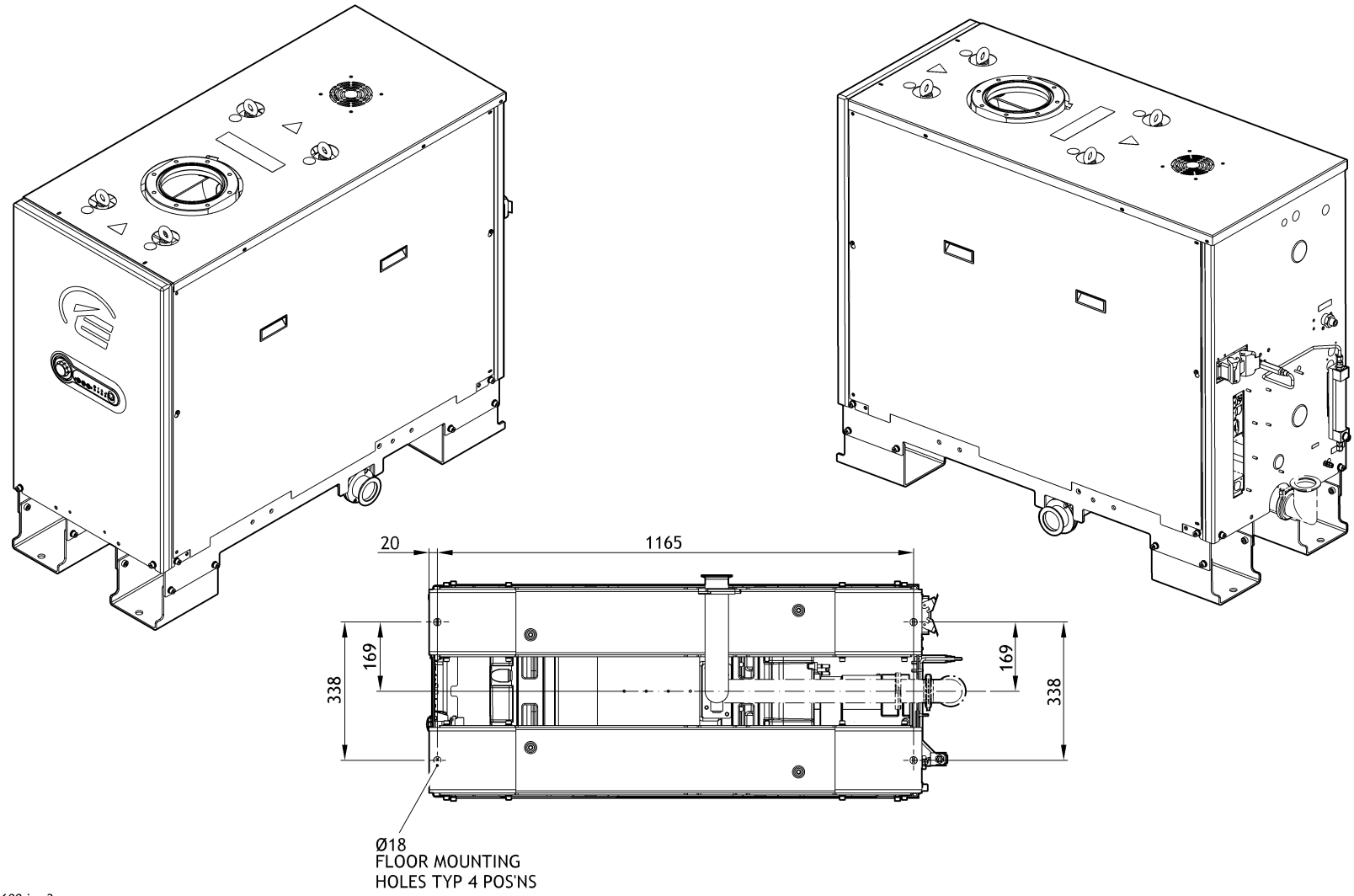



Figure A22 - GXS450/2600 installation drawing (Sheet 2)



GX450-2600 ins 2

dcs/8897/006

Figure A23 - GXS450/2600 installation drawing (Sheet 3)

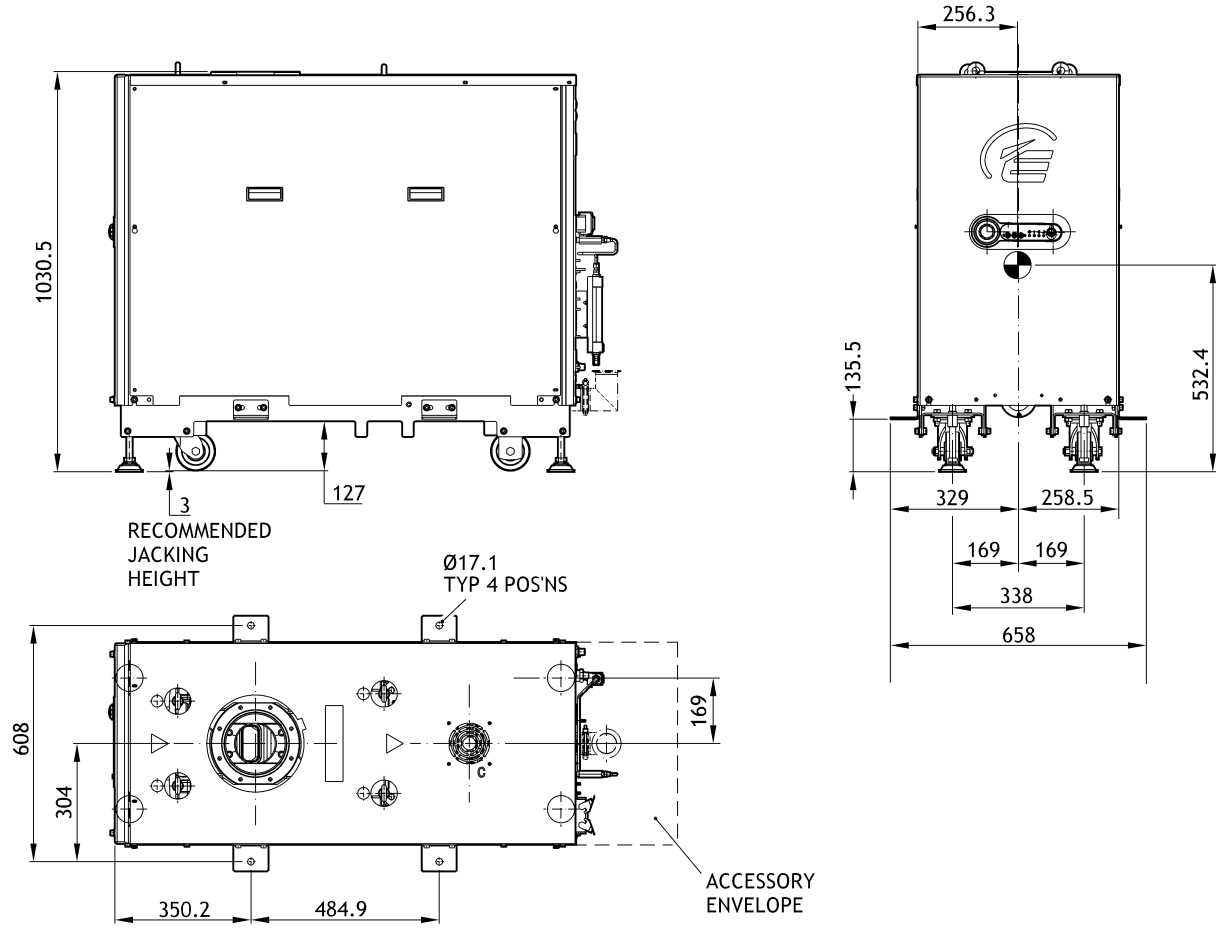
 IMAGES SHOWN WITH OPTIONAL CASTOR AND
 REAR EXIT EXHAUST ASSEMBLIES

dcs/8897/007

GXS450-2600 ins 3

Figure A24 - GXS450/2600 installation drawing (Sheet 4)

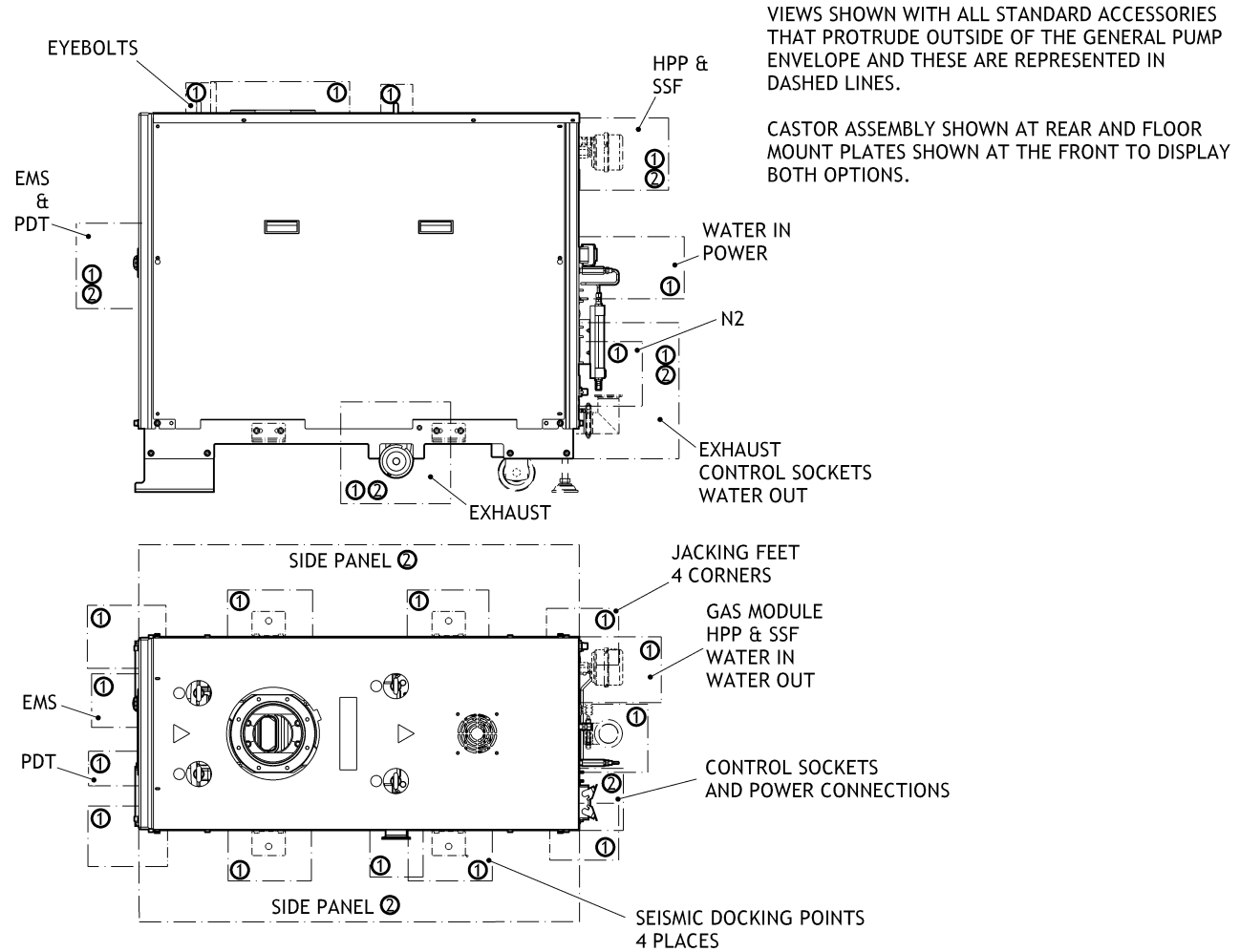

NOTES :
ACCESS SHOWN AS GUIDANCE ONLY

- ① RECOMMENDED ACCESS
- ② RECOMMENDED SERVICE ACCESS

GXS450-2600 ins 4

dcs/8897/008

A1.7 GXS450/4200

Figure A25 - GXS450/4200 installation drawing (Sheet 1)

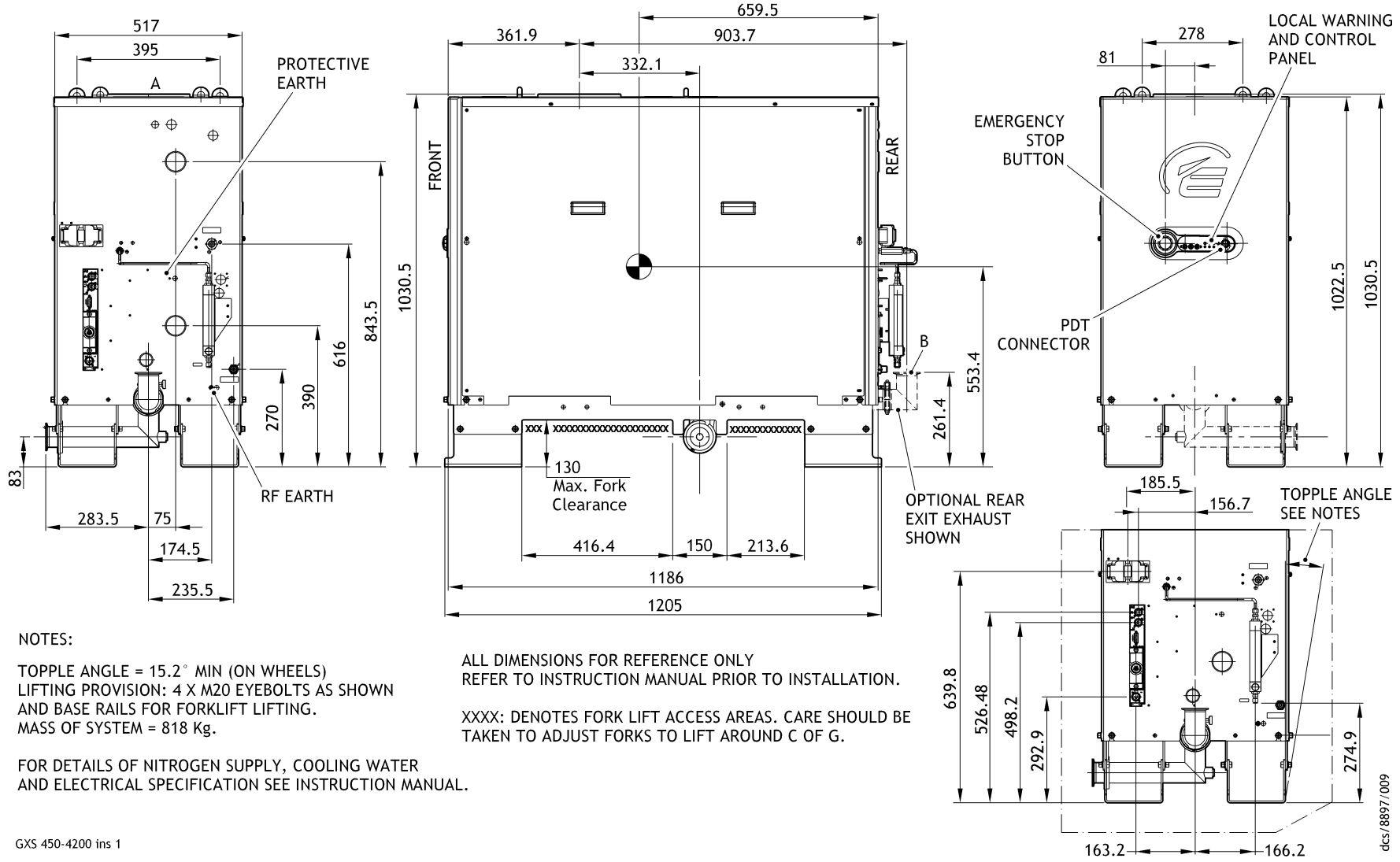

GXS 450-4200 ins 1

Figure A26 - GXS450/4200 installation drawing (Sheet 2)

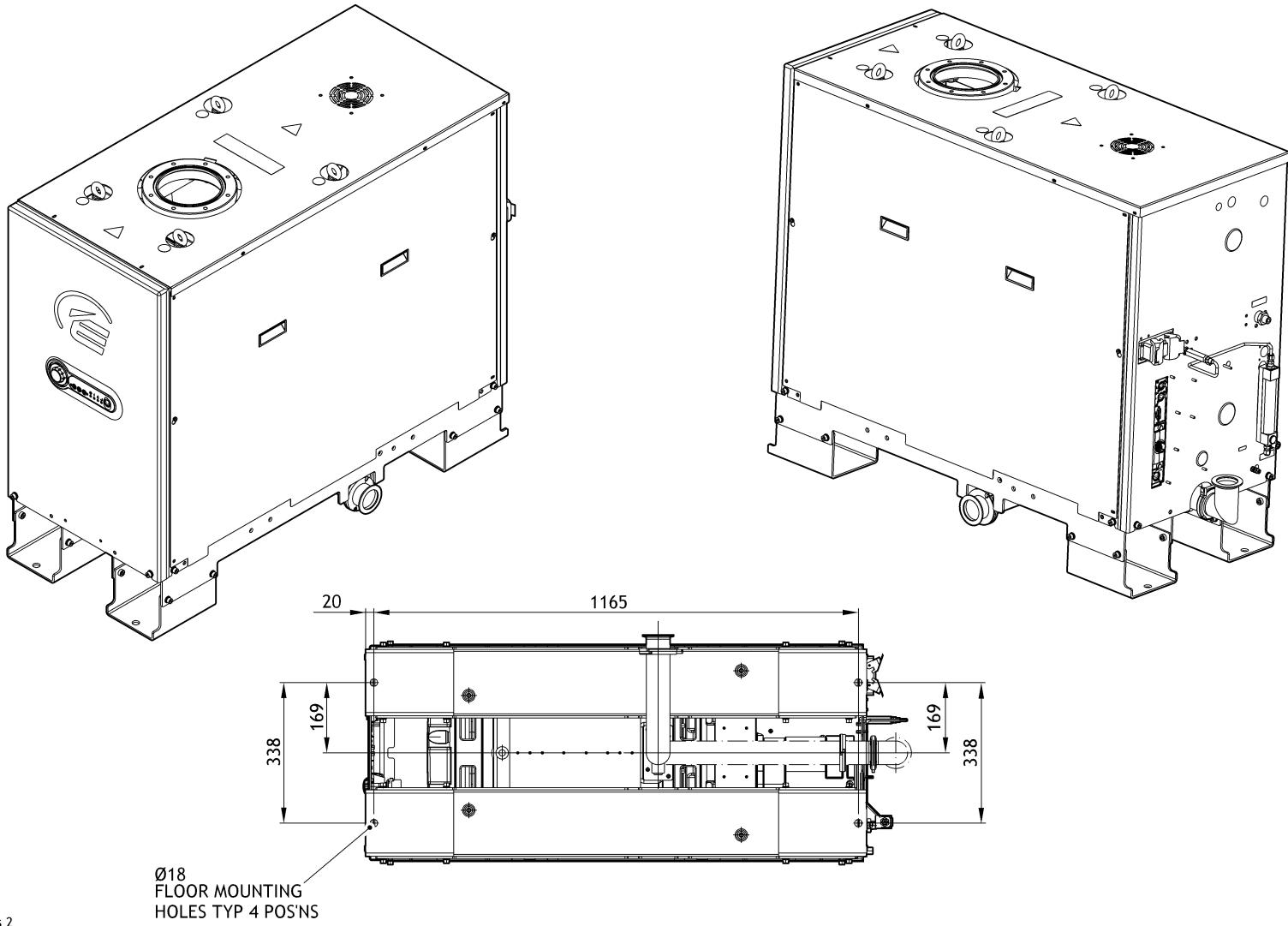

GXS 450-4200 ins 2

Figure A27 - GXS450/4200 installation drawing (Sheet 3)

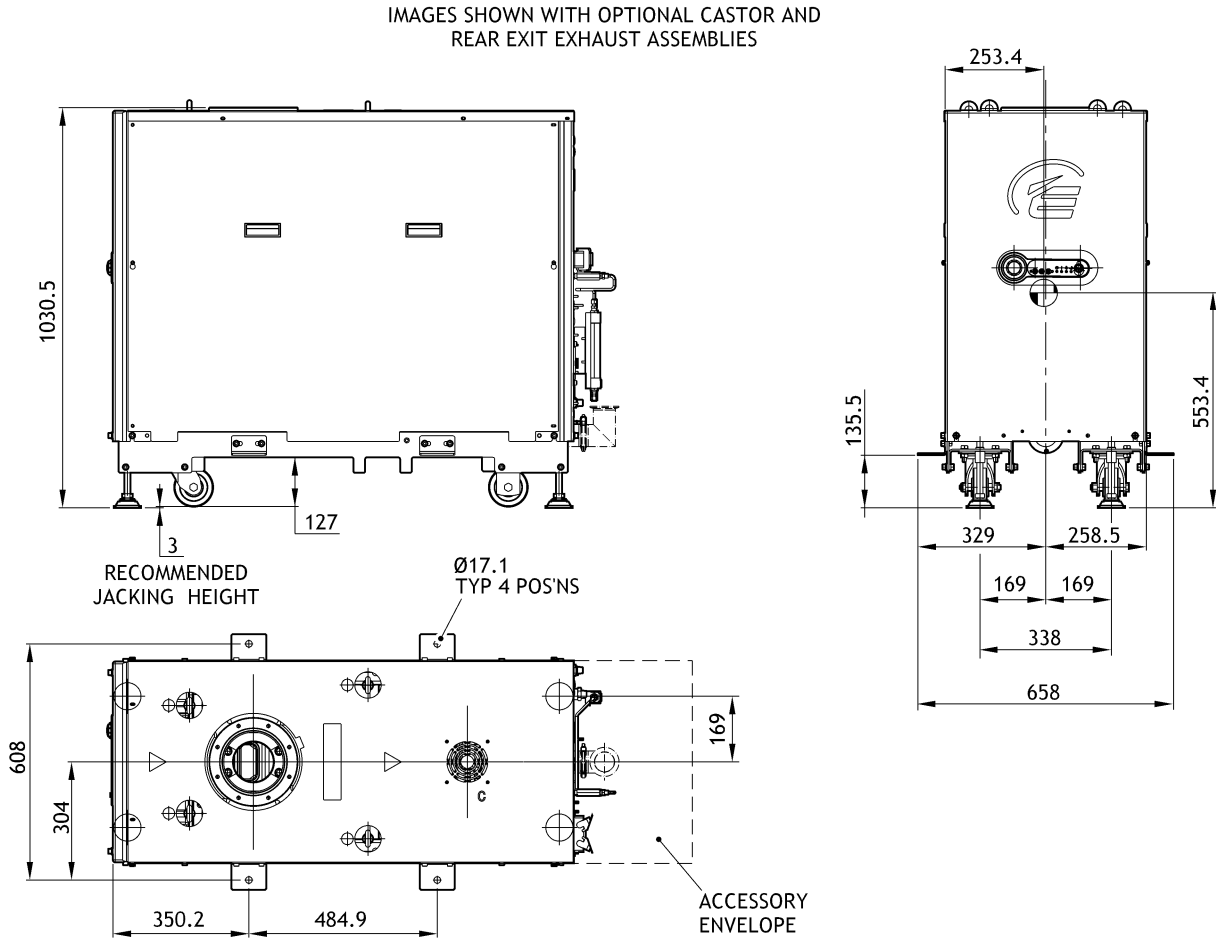

dcs/8897/011

GXS450-4200 ins 3

Figure A28 - GXS450/4200 installation drawing (Sheet 4)

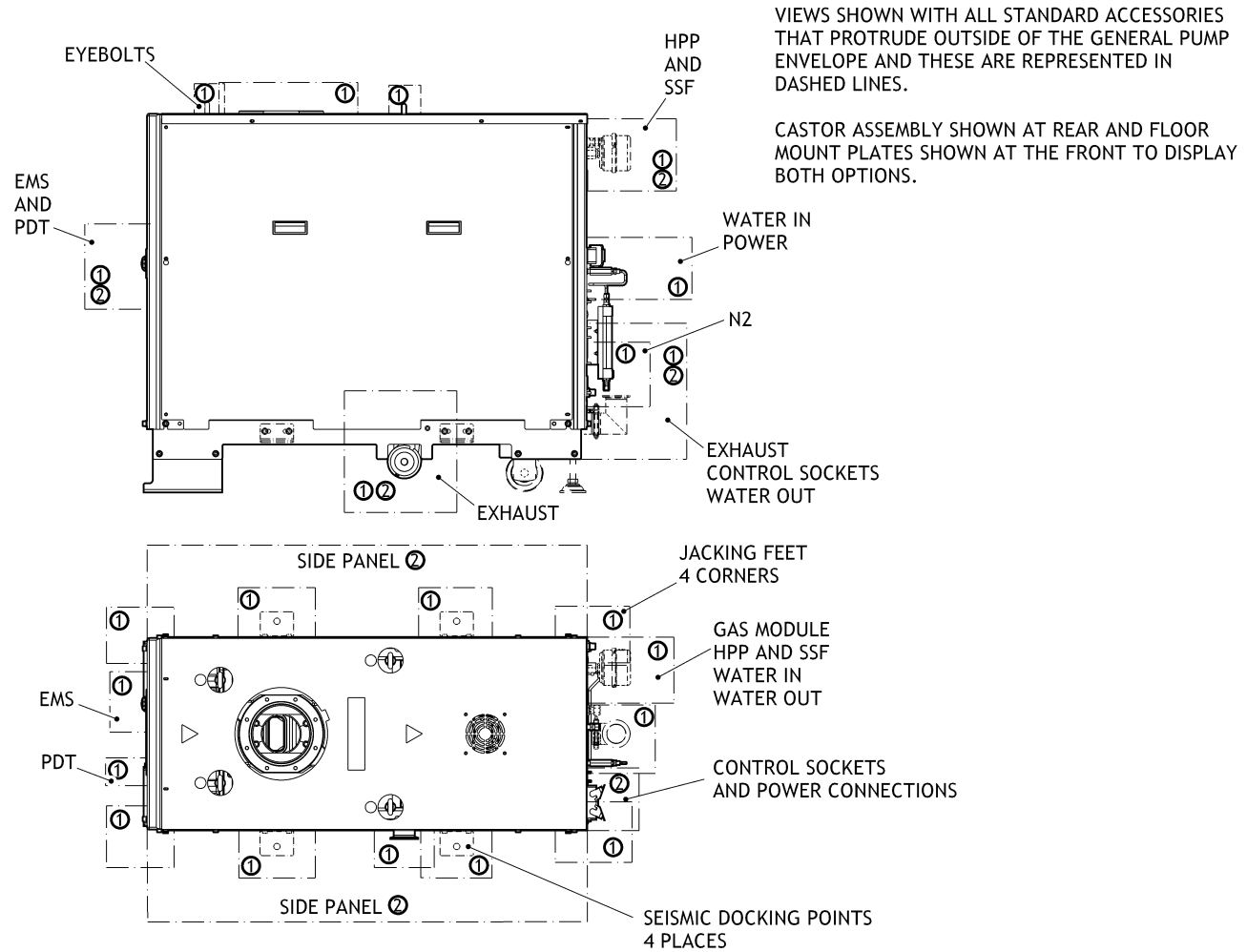

NOTES :
ACCESS SHOWN AS GUIDANCE ONLY

- ① RECOMMENDED ACCESS
- ② RECOMMENDED SERVICE ACCESS

GXS450-4200 ins 4

dcs/8897/012

A1.8 GXS750

Figure A29 - GXS750 installation drawing (Sheet 1)

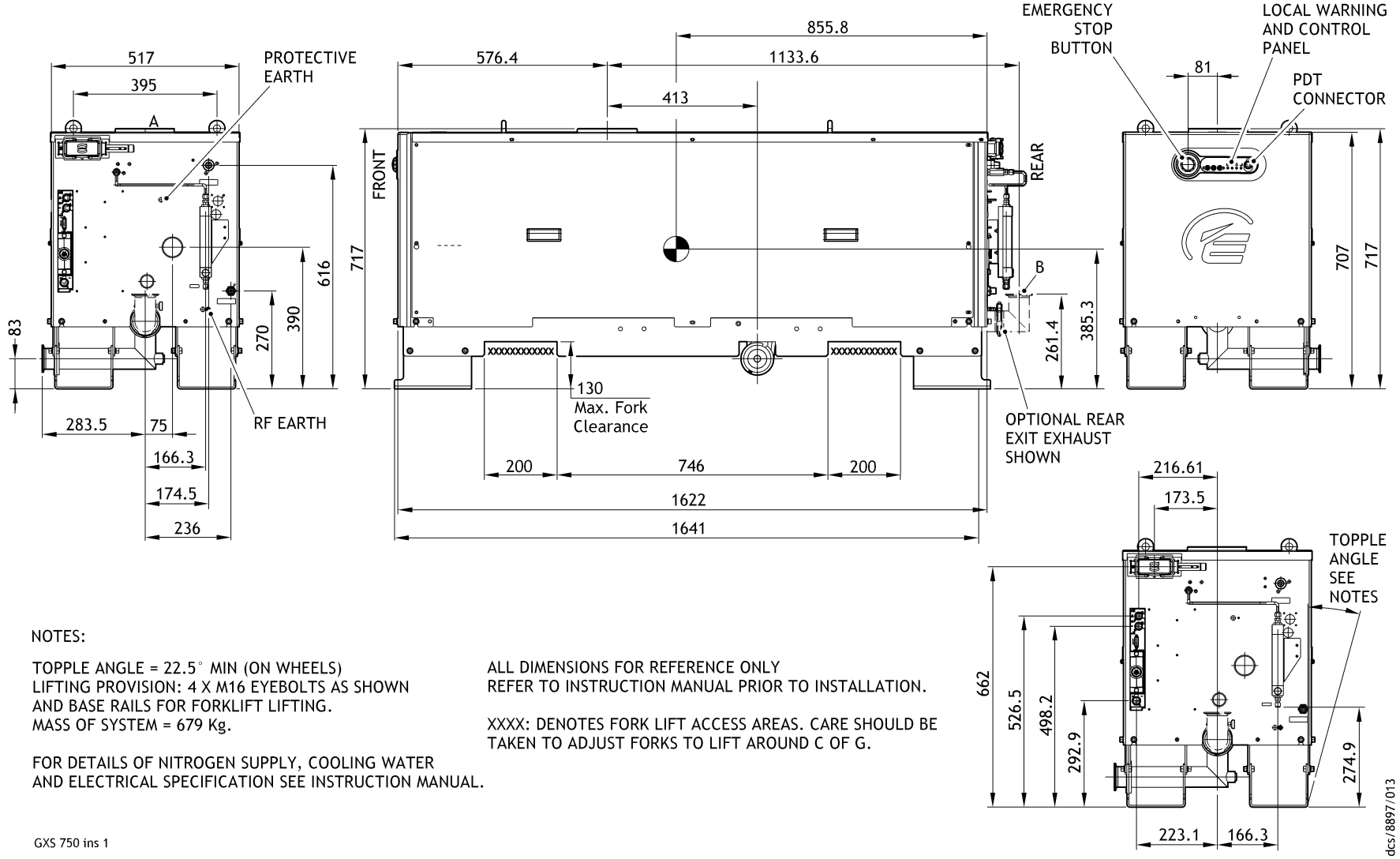

NOTES:

TOPPLE ANGLE = 22.5° MIN (ON WHEELS)
 LIFTING PROVISION: 4 X M16 EYEBOLTS AS SHOWN
 AND BASE RAILS FOR FORKLIFT LIFTING.
 MASS OF SYSTEM = 679 Kg.

FOR DETAILS OF NITROGEN SUPPLY, COOLING WATER
 AND ELECTRICAL SPECIFICATION SEE INSTRUCTION MANUAL.

ALL DIMENSIONS FOR REFERENCE ONLY
 REFER TO INSTRUCTION MANUAL PRIOR TO INSTALLATION.

XXXX: DENOTES FORK LIFT ACCESS AREAS. CARE SHOULD BE
 TAKEN TO ADJUST FORKS TO LIFT AROUND C OF G.

GXS 750 ins 1

dcsl/8897/013

Figure A30 - GXS750 installation drawing (Sheet 2)

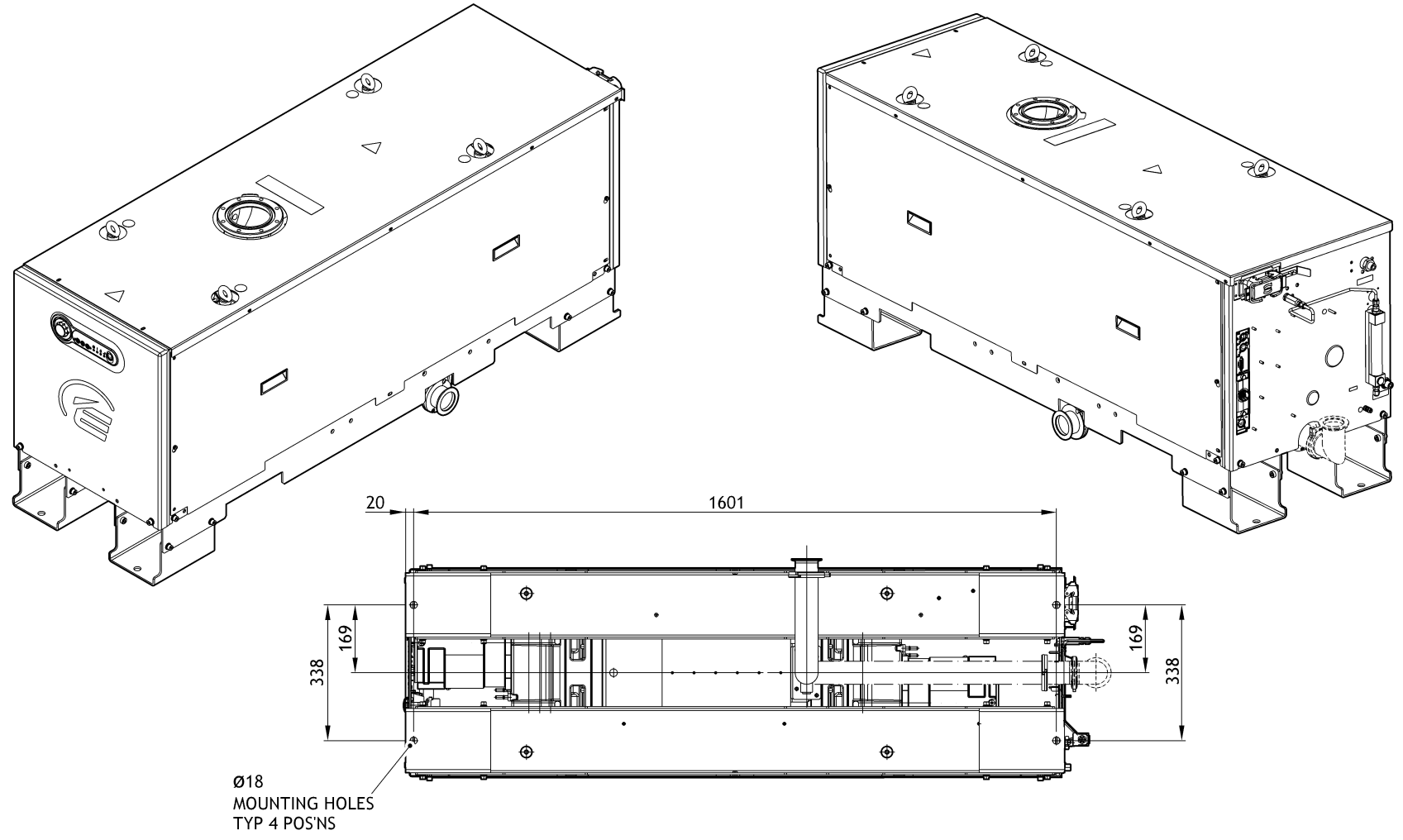

GXS 750 ins 2

Figure A31 - GXS750 installation drawing (Sheet 3)

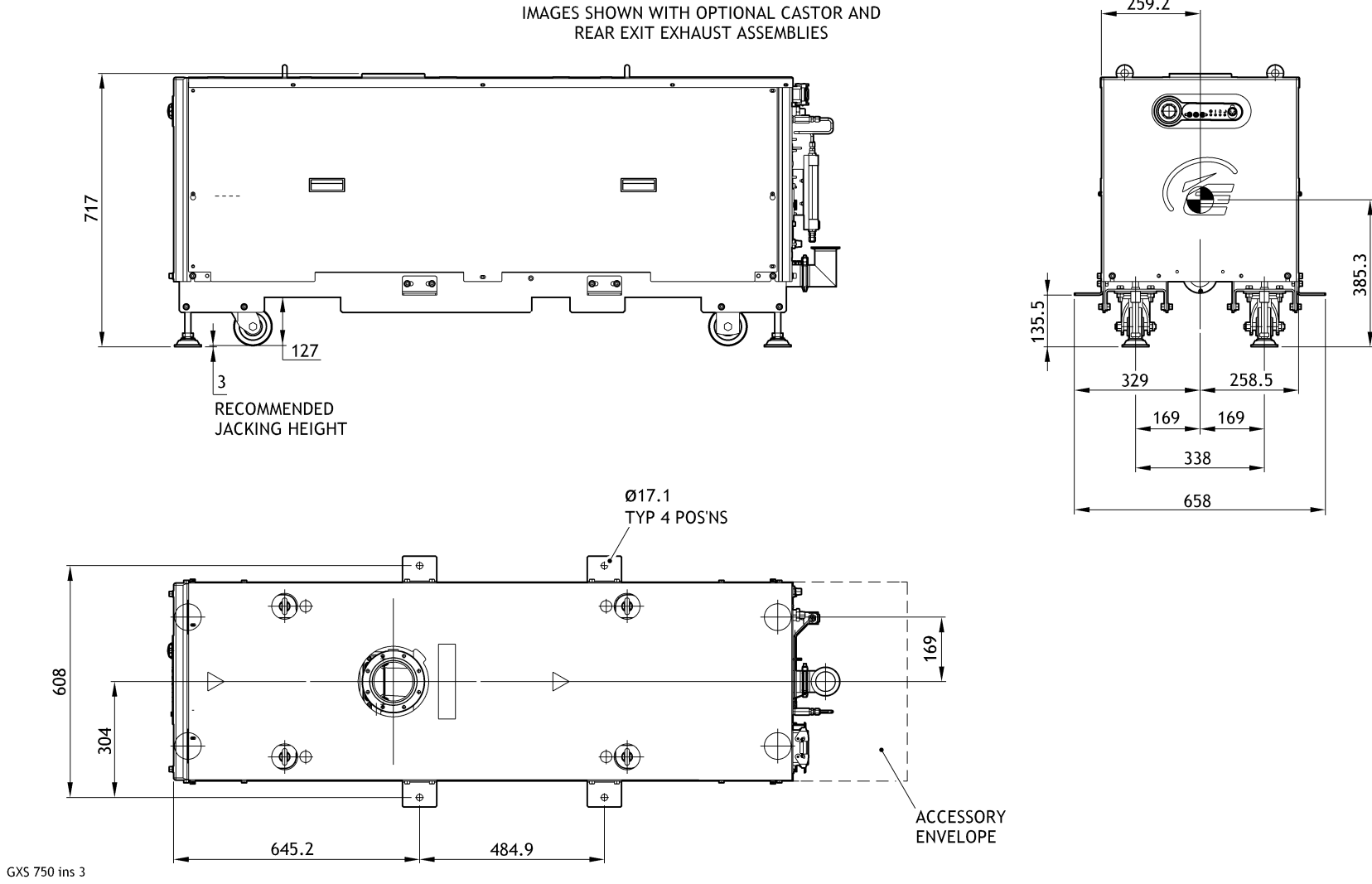

dcs/8897/015

M538-00-880 Issue E



Figure A32 - GXS750 installation drawing (Sheet 4)

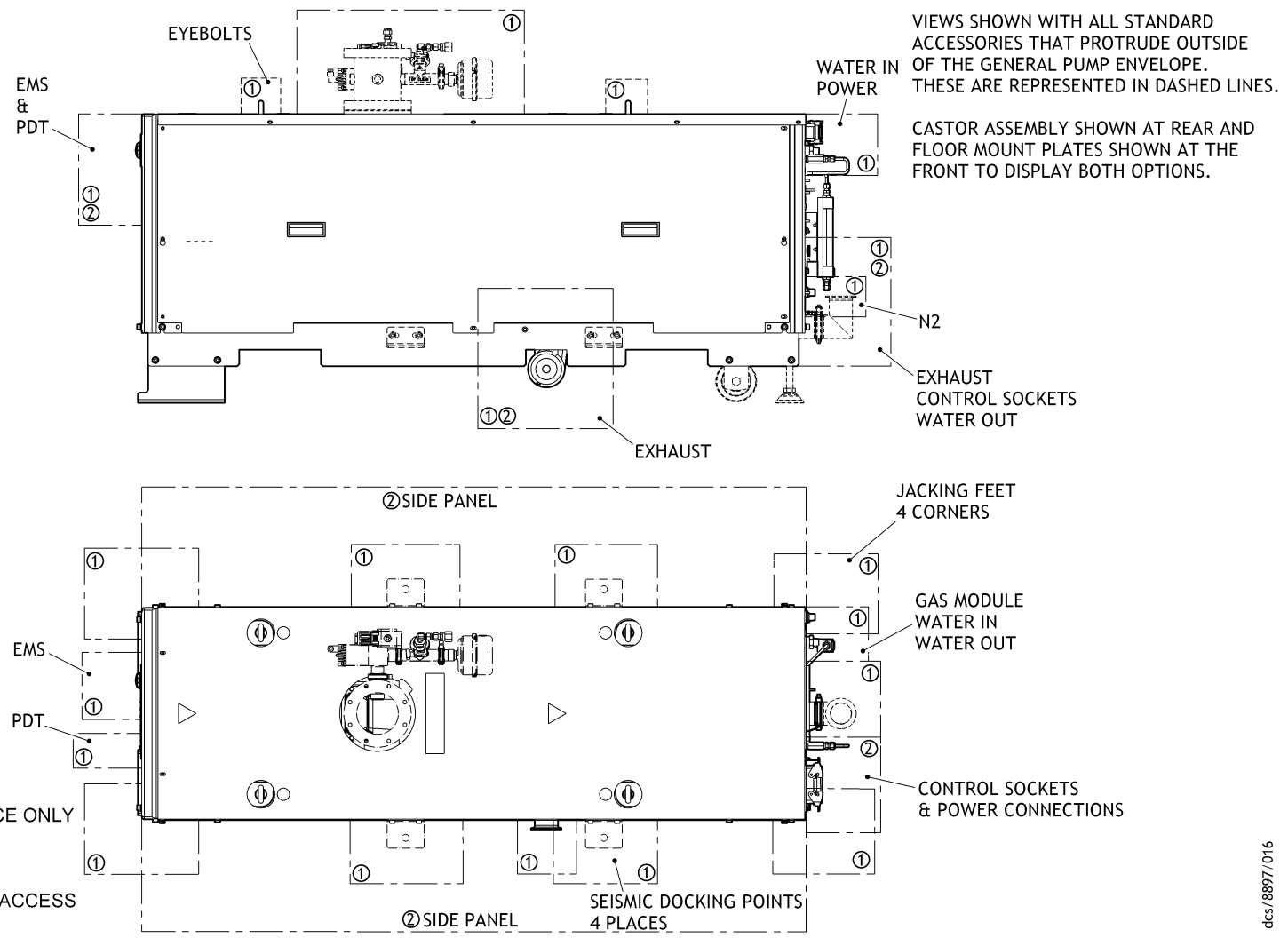

VIEWS SHOWN WITH ALL STANDARD ACCESSORIES THAT PROTRUDE OUTSIDE OF THE GENERAL PUMP ENVELOPE. THESE ARE REPRESENTED IN DASHED LINES.

CASTOR ASSEMBLY SHOWN AT REAR AND FLOOR MOUNT PLATES SHOWN AT THE FRONT TO DISPLAY BOTH OPTIONS.

dcs/8897/016



NOTES :
ACCESS SHOWN AS GUIDANCE ONLY

- ① RECOMMENDED ACCESS
- ② RECOMMENDED SERVICE ACCESS

GXS 750 ins 4

A1.9 GX5750/2600

Figure A33 - GX5750/2600 installation drawing (Sheet 1)

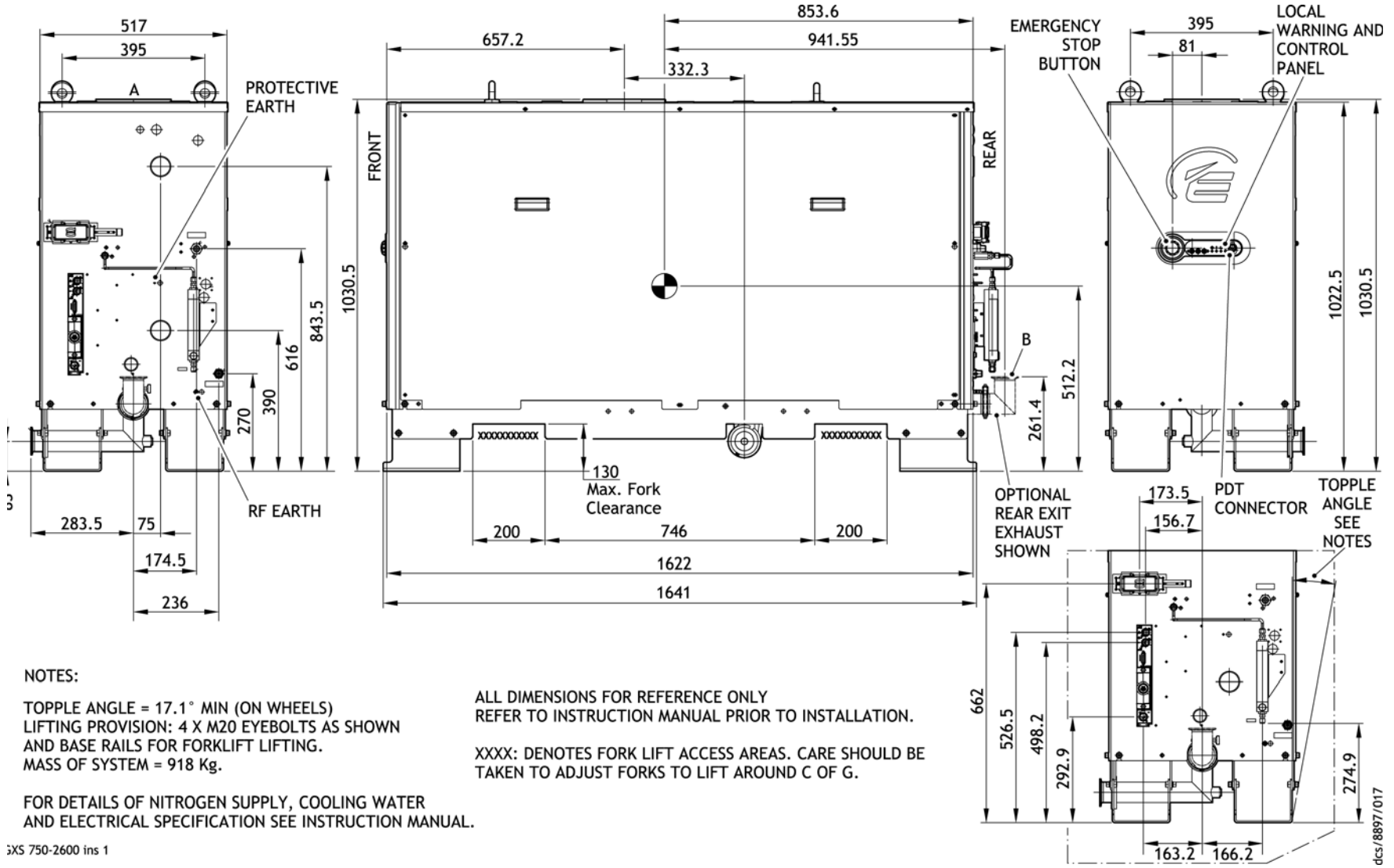

NOTES:

TOPPLE ANGLE = 17.1° MIN (ON WHEELS)
 LIFTING PROVISION: 4 X M20 EYEBOLTS AS SHOWN
 AND BASE RAILS FOR FORKLIFT LIFTING.
 MASS OF SYSTEM = 918 Kg.

FOR DETAILS OF NITROGEN SUPPLY, COOLING WATER
 AND ELECTRICAL SPECIFICATION SEE INSTRUCTION MANUAL.

ALL DIMENSIONS FOR REFERENCE ONLY
 REFER TO INSTRUCTION MANUAL PRIOR TO INSTALLATION.

XXXX: DENOTES FORK LIFT ACCESS AREAS. CARE SHOULD BE
 TAKEN TO ADJUST FORKS TO LIFT AROUND C OF G.

3XS 750-2600 ins 1

dc5/8897/017



dcsl/8897/018

Figure A34 - GXS750/2600 installation drawing (Sheet 2)

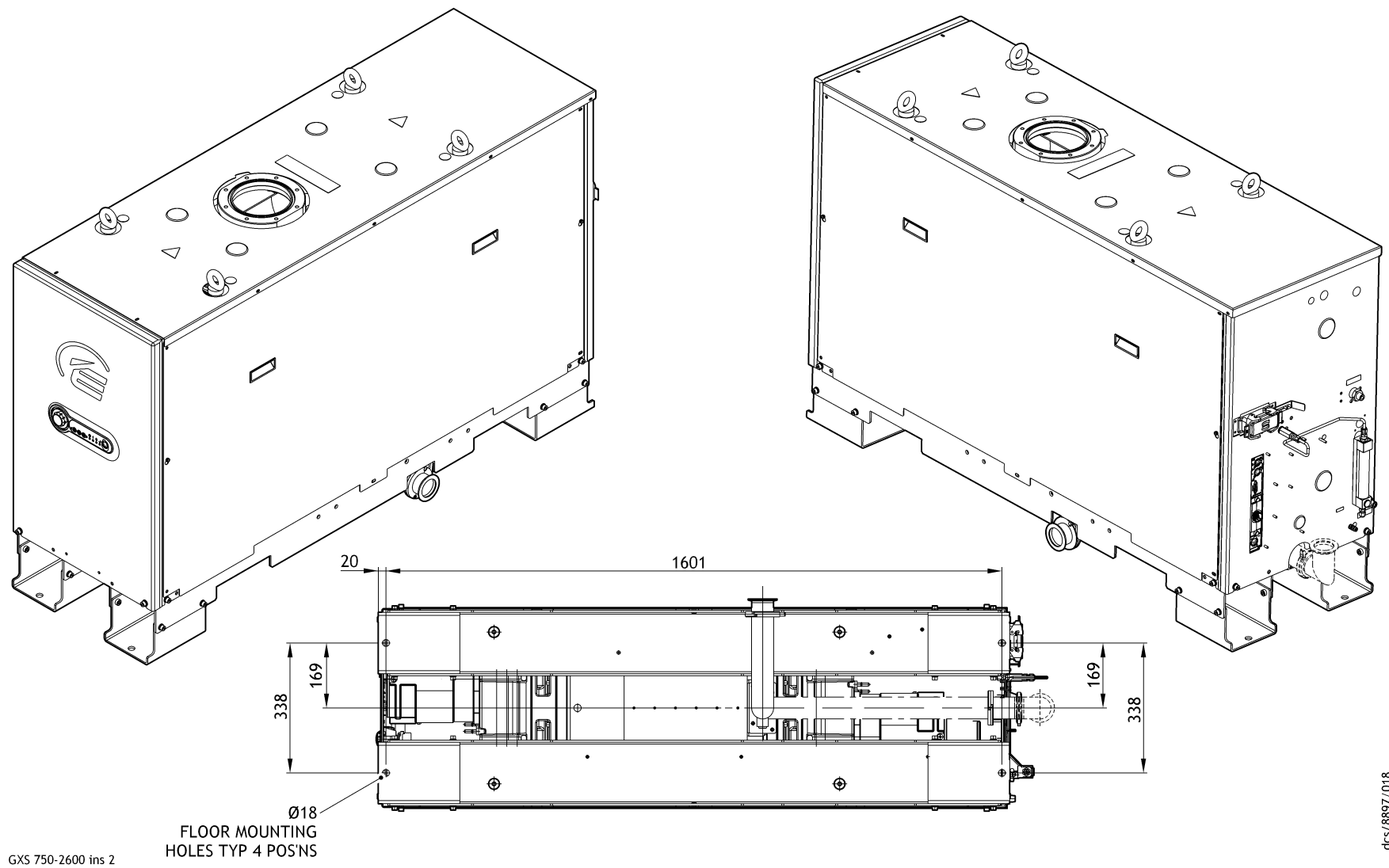

GXS 750-2600 ins 2

FLOOR MOUNTING HOLES TYP 4 POS'NS
 $\varnothing 18$

Figure A35 - GX5750/2600 installation drawing (Sheet 3)

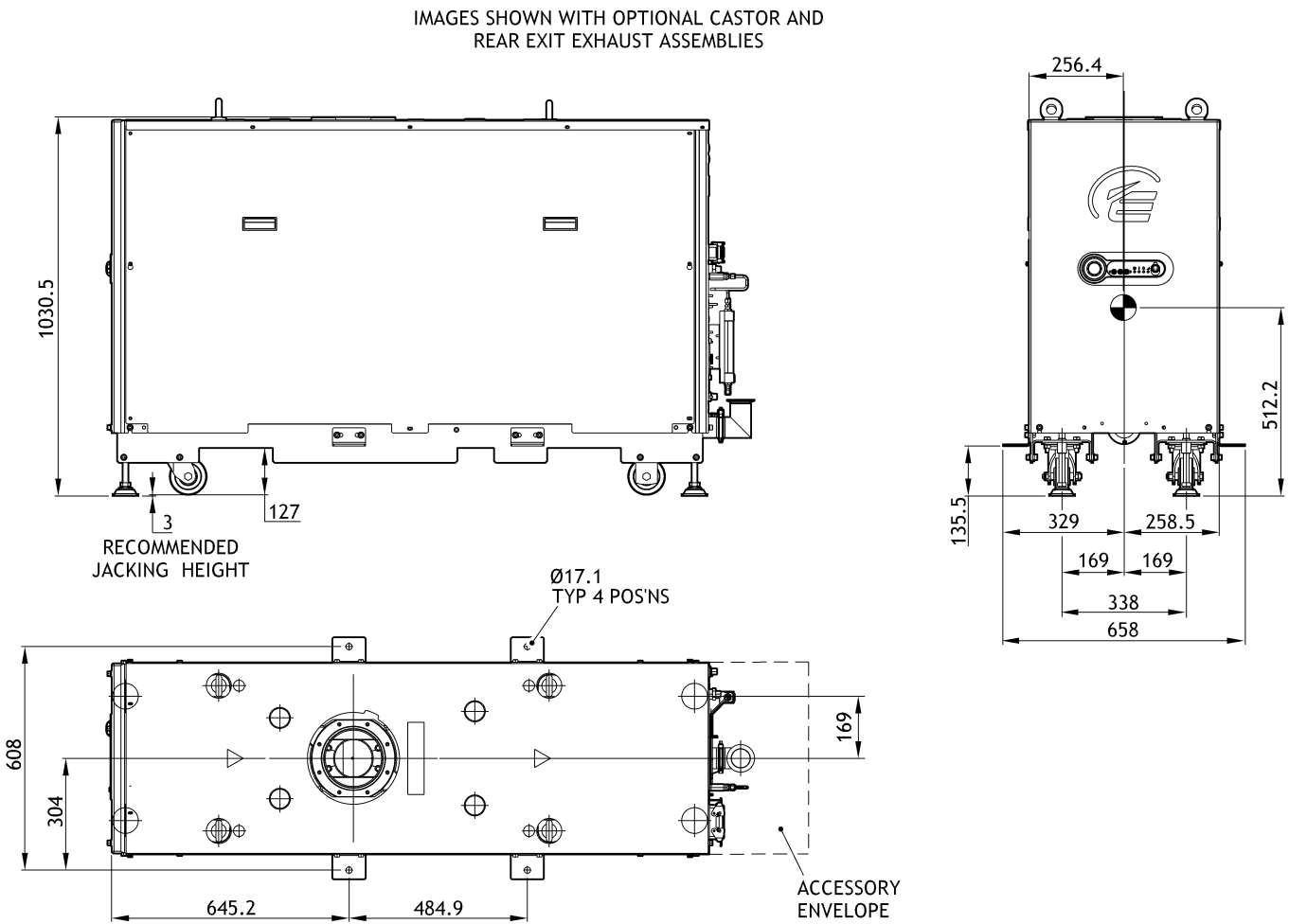

GX5750-2600 ins 3

Figure A36 - GX5750/2600 installation drawing (Sheet 4)

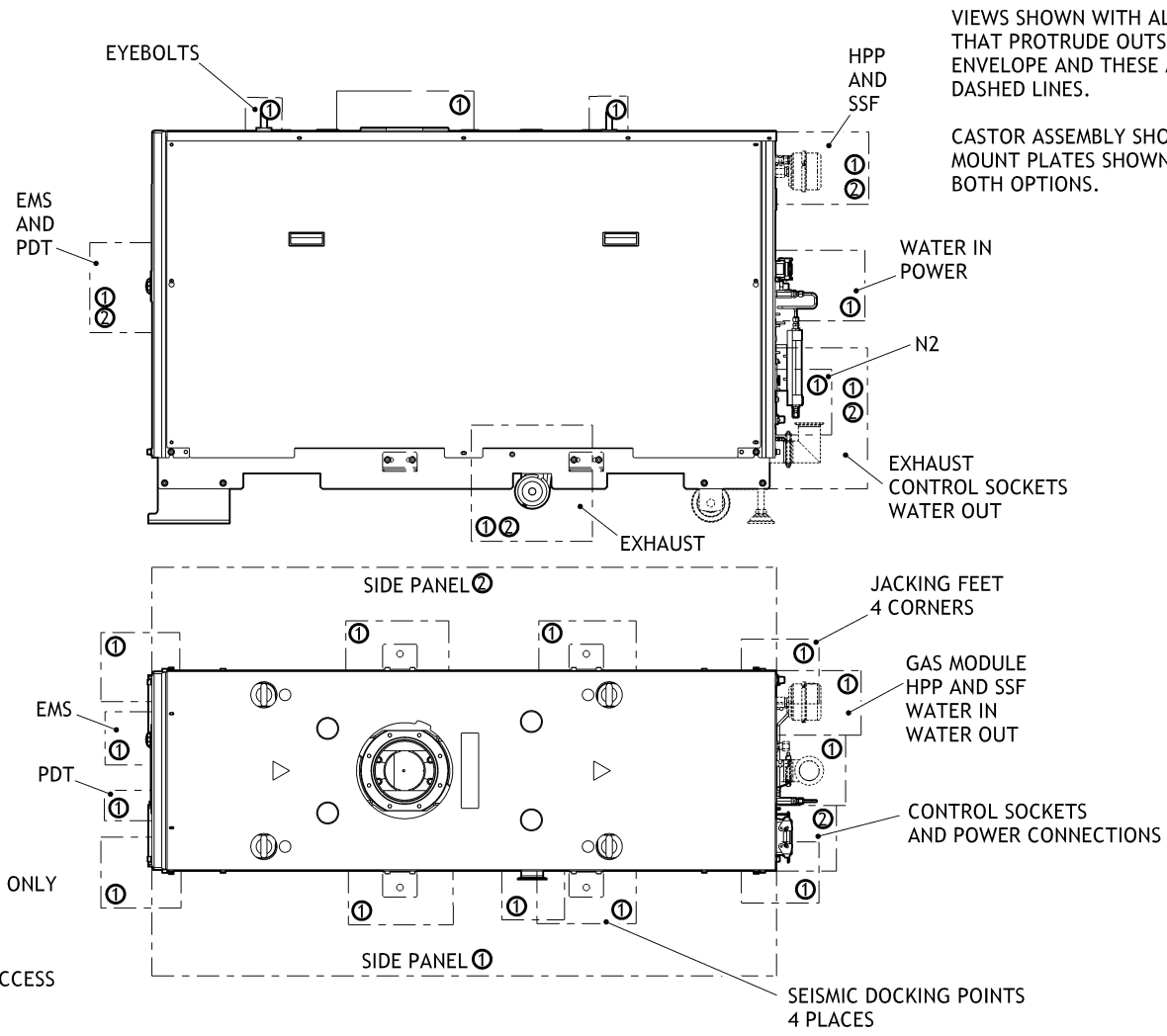

VIEWS SHOWN WITH ALL STANDARD ACCESSORIES THAT PROTRUDE OUTSIDE OF THE GENERAL PUMP ENVELOPE AND THESE ARE REPRESENTED IN DASHED LINES.

CASTOR ASSEMBLY SHOWN AT REAR AND FLOOR MOUNT PLATES SHOWN AT THE FRONT TO DISPLAY BOTH OPTIONS.

- NOTES :
- ACCESS SHOWN AS GUIDANCE ONLY
 - ① RECOMMENDED ACCESS
 - ② RECOMMENDED SERVICE ACCESS

GX5750-2600 ins 4

dcs/8897/020



A1.10 GXS750/4200

Figure A37 - GXS750/4200 installation drawing (Sheet 1)

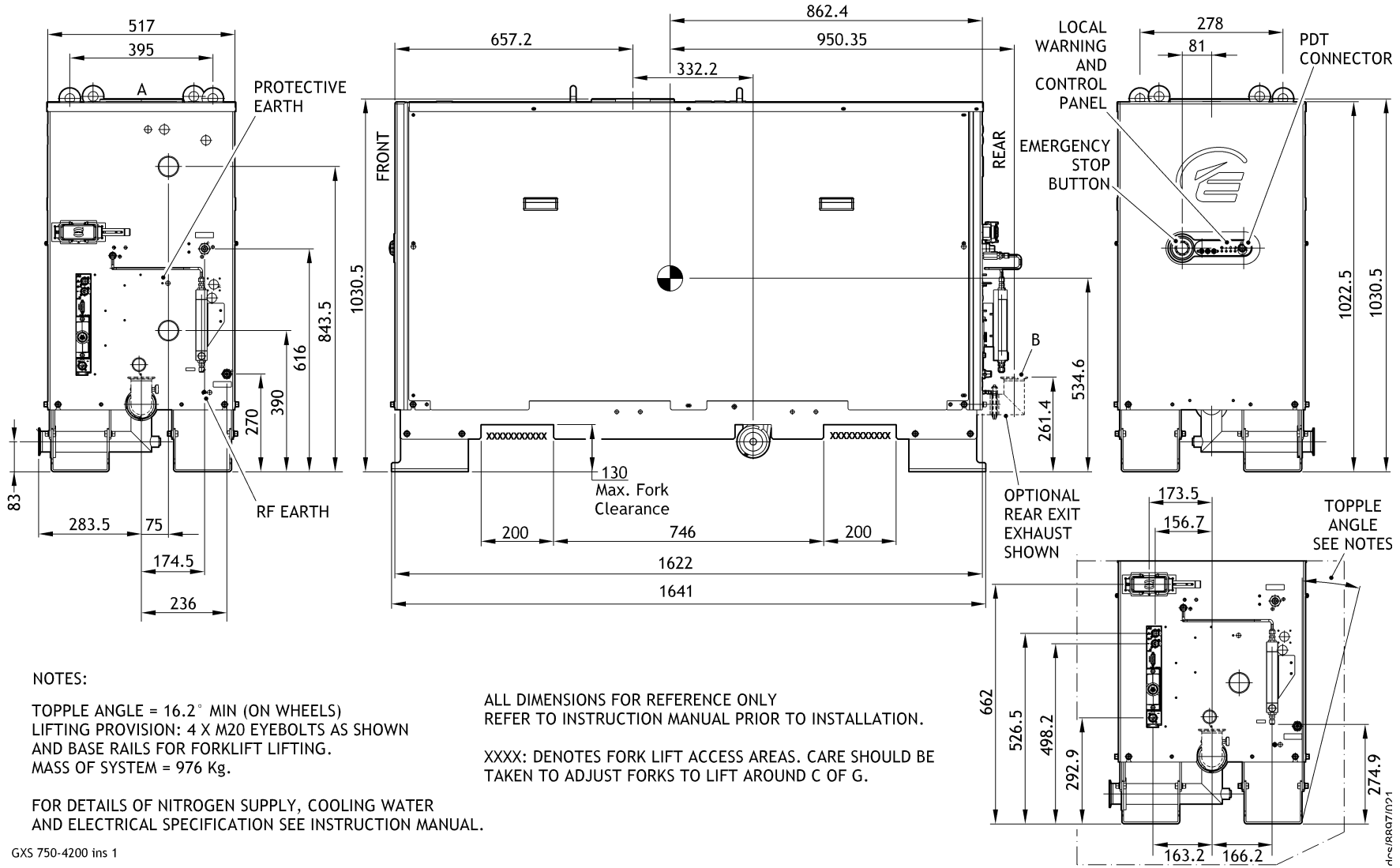

NOTES:

TOPPLE ANGLE = 16.2° MIN (ON WHEELS)
 LIFTING PROVISION: 4 X M20 EYEBOLTS AS SHOWN
 AND BASE RAILS FOR FORKLIFT LIFTING.
 MASS OF SYSTEM = 976 Kg.

FOR DETAILS OF NITROGEN SUPPLY, COOLING WATER
 AND ELECTRICAL SPECIFICATION SEE INSTRUCTION MANUAL.

ALL DIMENSIONS FOR REFERENCE ONLY
 REFER TO INSTRUCTION MANUAL PRIOR TO INSTALLATION.

XXXX: DENOTES FORK LIFT ACCESS AREAS. CARE SHOULD BE
 TAKEN TO ADJUST FORKS TO LIFT AROUND C OF G.

GXS 750-4200 ins 1



dc5/8897/022

Figure A38 - GXS750/4200 installation drawing (Sheet 2)

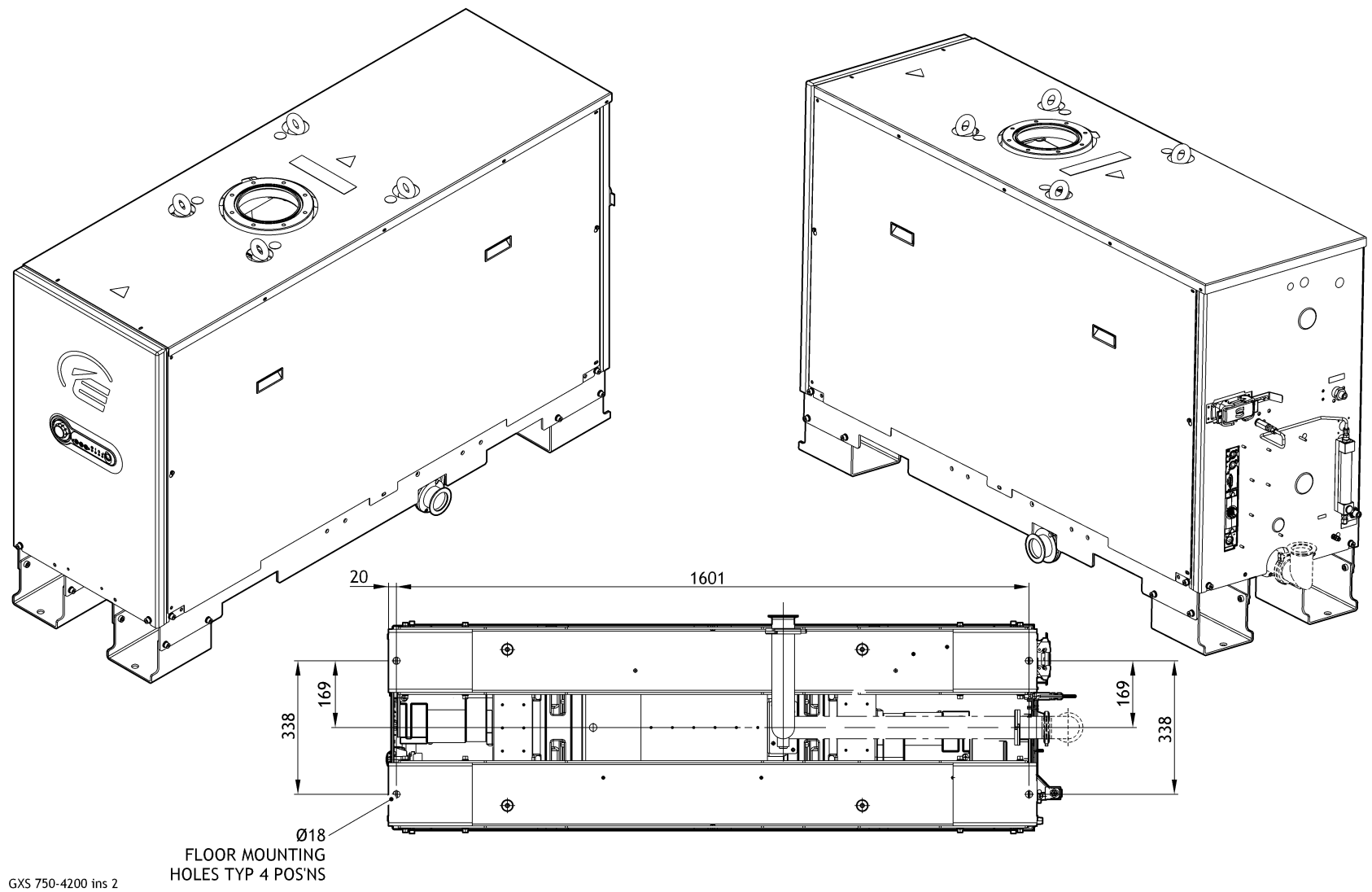

GXS 750-4200 ins 2

FLOOR MOUNTING HOLES TYP 4 POS'NS

$\varnothing 18$

338
169

1601

20

338
169

Figure A39 - GX5750/4200 installation drawing (Sheet 3)

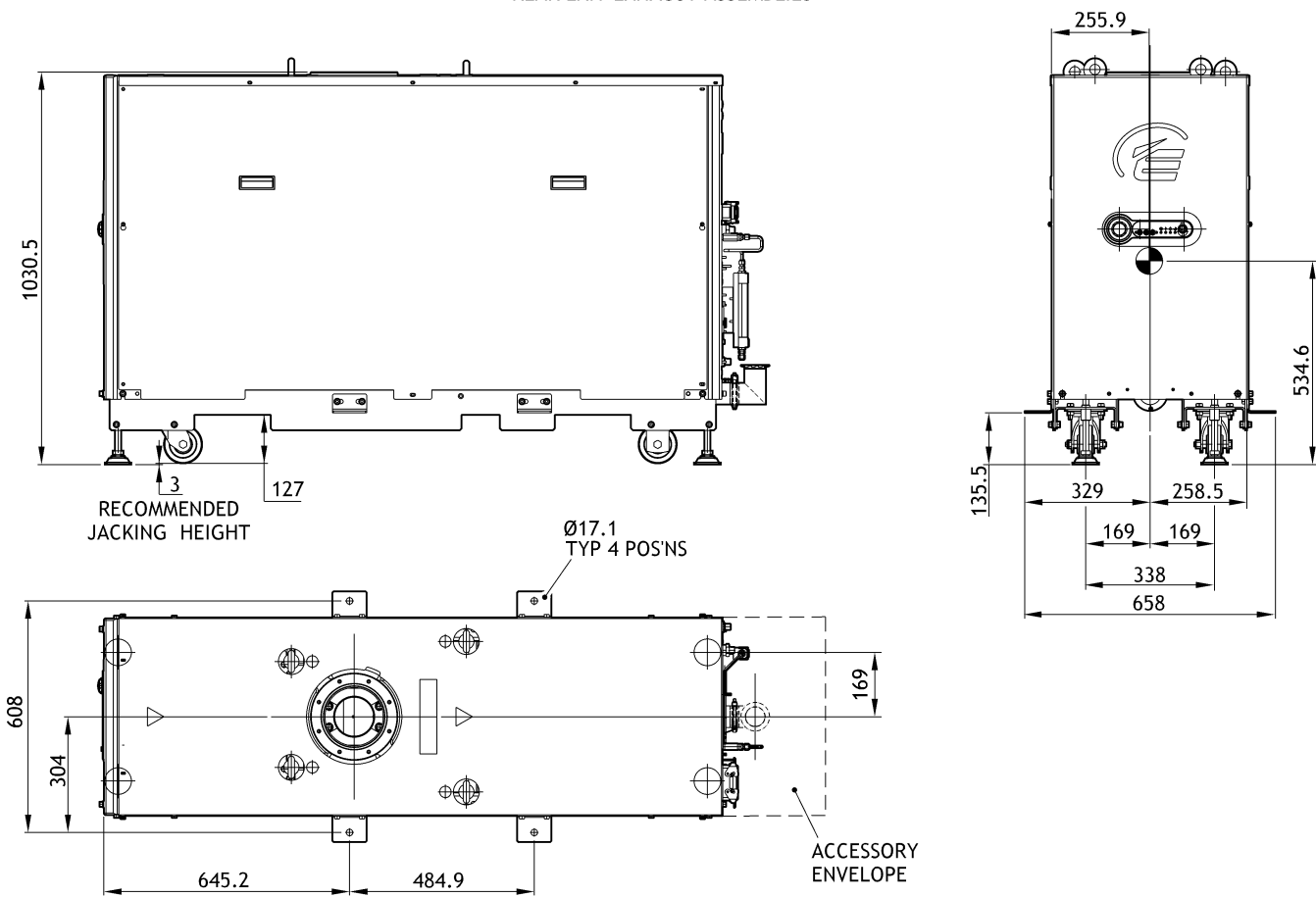
 IMAGES SHOWN WITH OPTIONAL CASTOR AND
 REAR EXIT EXHAUST ASSEMBLIES

GX5750-4200 ins 3

Figure A40 - GXS750/4200 installation drawing (Sheet 4)

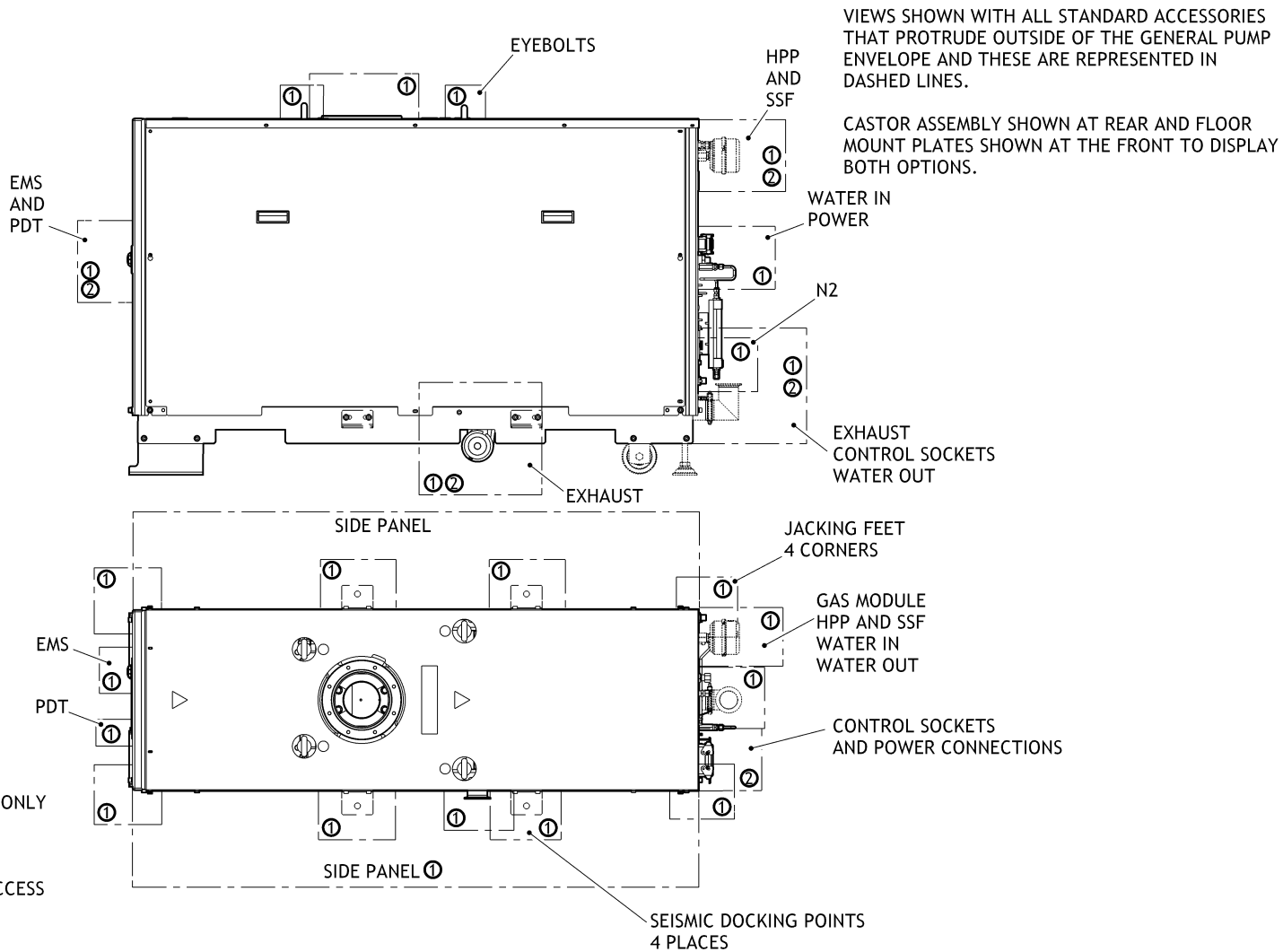

VIEWS SHOWN WITH ALL STANDARD ACCESSORIES THAT PROTRUDE OUTSIDE OF THE GENERAL PUMP ENVELOPE AND THESE ARE REPRESENTED IN DASHED LINES.

CASTOR ASSEMBLY SHOWN AT REAR AND FLOOR MOUNT PLATES SHOWN AT THE FRONT TO DISPLAY BOTH OPTIONS.

NOTES :
ACCESS SHOWN AS GUIDANCE ONLY

- ① RECOMMENDED ACCESS
- ② RECOMMENDED SERVICE ACCESS

GXS750-4200 ins 4

dcs/8897/024



Appendix A2 Pump display terminal

The PDT accessory provides pump on/off and status reporting. Warnings and alarms are also indicated to the user. Up to two PDTs may be fitted.

Figure A41 - Pump display terminal



A2.1 LEDs

LOCAL CONTROL green illuminates continuously when this PDT has control of the pump.

PUMP ON green (within the pump start button) illuminates to indicate that the pump is running. The LED illuminates continuously when the pump is on-process and flashes when the pump is warming up, stopping or when it is in Green Mode/Standby mode.

WARNING yellow illuminates to indicate that a pump warning is present. It flashes when a new warning occurs until it is acknowledged by pressing **ENTER** when it goes continuous until the warning clears. The warning LED also flashes when a new event is present. Once the event has been acknowledged the warning LED will return to its previous state.

ALARM red illuminates to indicate that a pump alarm is present. It flashes when a new alarm occurs until it is acknowledged by pressing **ENTER** when it goes continuous until the alarm clears.

A2.2 Pump start / stop and control

To start or stop the pump the PDT must be in control, indicated by the local control LED being illuminated.

To take or release control briefly press **CONTROL**.

If something else is in control, error message 'Control locked' appears, refer to 'Control Holder' in the status menu.

Press Start  button PDT displays:

Table A1 - PDT displays

Pump state	Local control LED	PDT display	Operator	Pump response
Stopped	On	START MENU Start Pump	Press ENTER to confirm	Pump starts
Running	On	Pump Running Press CANCEL	Press CANCEL	No change (running)
Stopped or Running	Off	No PDT Control Press CANCEL	Press CANCEL	No change

Press Stop  button PDT displays:

Table A2 - PDT displays

Pump state	Local control LED	PDT display	Operator	Pump response
Stopped	On	PUMP Stopped Press CANCEL	Press CANCEL	No change (stopped)
Running	On	STOP MENU Auto Shutdown	If Fast Shutdown is required press down arrow. Press ENTER to confirm	Pump Stops
Stopped or Running	Off	No PDT Control Press CANCEL	Press CANCEL	No change

A2.3 Event / warning / alarm display and acknowledgement

Each new event / warning / alarm is displayed when it occurs, overwriting any text already present unless another unacknowledged event /warning / alarm is currently being displayed. The corresponding warning / alarm LED flashes to indicate a new event /warning / alarm.

Pressing **ENTER** acknowledges the event /warning / alarm currently displayed and the warning / alarm LED stops flashing. If available the display will show the suggested action, press **ENTER** again to clear.

If there is another new event /warning or alarm the warning / alarm LED will continue to flash and this is then displayed, otherwise the display will revert to the original text from before the alarm(s) / warning(s) / event(s) occurred.

If there are warnings / alarms still present, but they are all acknowledged, then the corresponding LED remains continuously illuminated. The text indicating acknowledged warning / alarm conditions still present may be viewed in the **Status** menu, refer to status menu contents in [Appendix A2.4.2](#). Some alarms such as 1.01 STOP ACTIVATED remain present until the pump is manually started from the PDT or front panel controls.

Once all warning/alarm conditions have gone away, then the corresponding LED is extinguished.

To avoid a build up of out of date Warnings they are automatically acknowledged after 36 hours.

A2.4 Menus

There are three menu buttons **NORMAL**, **STATUS** and **SETUP** described below.

NR in the data part of a parameter indicates no reading.

NP in the data part of a parameter indicates a parameter that is not present.

A2.4.1 Normal menu

This menu is displayed when the PDT is first plugged into the pump, or accessed by pressing the **NORMAL** button. Up to 4 parameters are displayed, scroll by pressing up/down keys.

Table A3 - Normal menu

Description	Typical display
Serial Number	S/N 1234567
Control Holder	NONE IN CONTROL
Dry Pump current	DP CURRENT 1.1 A
Booster current	MB CURRENT 1.1 A

By default the 4 parameters displayed in the normal menu are as shown in [Table A3](#) above. It is possible to change the parameters displayed, refer to [Appendix A2.5](#).

A2.4.2 Status menu

Press the **STATUS** button to enter. Scroll by pressing **UP/DOWN** keys. Press **CANCEL** to exit back to **Normal** menu.

If a device is not fitted the associated parameters will not be displayed. Parameters displayed:

Table A4 - Typical display

Description	Typical display
Serial Number	S/N 1234567
Control Holder	NONE IN CONTROL
Dry Pump current	DP CURRENT 1.1 A
Booster current	MB CURRENT 1.1 A
Green Mode state	Green Mode STATE Off
Inlet isolation valve open/closed state	ISOL VALVE Open
Dry pump stator reference temperature	TCS REF 100 C
Dry Pump temperature	DP TEMP 100 C
Dry Pump exhaust stage temperature	DP EXH STG 63 C
Dry Pump End Cover temperature	DP E/C TEMP 100 C
Booster temperature	MB TEMP 100 C
Booster End Cover temperature	MB EC TEMP 100 C
Nitrogen flow switch status	N2 Supply OK
Dry Pump Power	DP POWER 1.1 kW
Booster Power	MB POWER 1.1 kW
Dry Pump speed in percent	DP SPEED 100 %
Dry Pump speed in Hz	DP SPEED 100 Hz

Table A4 - Typical display (continued)

Description	Typical display	
Booster speed in percent	MB SPEED	100 %
Booster speed in Hz	MB SPEED	100 Hz
Dry pump inverter temperature	DP INV TEMP	100 C
Booster inverter temperature	MB INV TEMP	100 C
Exhaust pressure	EXHAUST	5 PSI
Exhaust temperature	EXH PIPE TEMP	100 C
Water flow rate	WATER	11.1 l/m
Run hours	RUN HOURS	1000
Number of pump starts	PUMP STARTS	100
Time to stop (seconds)	TIME TO STOP	900
Active alarms and warnings		
Solvent soak	SOLVENTSOAK	Off
Dry pump clean	DP CLEAN	Off
Active strain gauge	ASG	3.4E+01 mbar
PT100 temperature	PT100 1	108 C
Pressure transducer	PR	105.0 kPa
PID Auto tune status	PID TUNE	Normal

A2.4.3 Setup menu

Press the **SETUP** button to enter. Menu title is shown at the top of the display. Scroll by pressing **UP/DOWN** keys. Press **ENTER** to open a sub menu or **CANCEL** to exit back to **Normal** menu.

Table A5 - PDT setup menu structure

Description	Display
Commands menu*	Command Menu...
Set sequences menu*	Set Sequences...
Display Inverter Fault History menu	Inv Fault Hist...
Software Version Display menu	S/W Version...
Display Serial Number	Serial Num...
Fit Accessory menu*	Fit Accessory...
Edit IP configuration menu	IP Config...
Edit Display Attributes menu	Display Attr...
Set Time and Date	Set Clock...
Display Pump Type	Show pump type...

* This option requires a security code to access it

Each sub menu is described below.

A2.4.4 Commands menu

Under the **Setup** menu. Scroll by pressing **UP/DOWN** keys. Press **ENTER** to open a sub menu or **CANCEL** to exit back to the **Setup** menu. A security code is needed to enter the **Commands** menus: 202.

Table A6 - Commands menu

Commands menu
Inlet Isolation Valve (Open/Shut)
MB Pump (On/Off)*
Green Mode
Green Level
Solvent Soak
DP Clean
Gas Valves
PID Autotune
PID (On/Off)
2nd DP Speed
2nd MB Speed
Test Mode (On/Off)

* *The PDT must be in control to perform these functions.*

Press the **UP/DOWN** keys to select the new settings and press **ENTER** to accept or **CANCEL** to exit back to the **Commands** menu.

A2.4.4.1 Gas valves menu

Scroll by pressing **UP/DOWN** keys. Press **ENTER** to open a sub menu or **CANCEL** to exit back to the **Setup** menu. Settings do not appear if they are not fitted.

Table A7 - Gas valves menu

Gas valves menu
Set N ₂ Seal
Set Gas Ballast
Set Inlet

Press the **UP/DOWN** keys to select **on / off** and press **ENTER** to accept or **CANCEL** to exit back to the **Gas valves** menu.

A2.4.5 Set sequences menu

Under the **Setup** menu. Scroll by pressing **UP/DOWN** keys. Press **ENTER** to open a sub menu or **CANCEL** to exit back to the **Setup** menu. A security code is needed to enter the **Set sequences** menus:202.

Table A8 - Set sequences menu

Option	Text on PDT line 2	Options on PDT line 2 after pressing Enter (use up/down arrow to change, enter to select)
Warm up Sequence	Warmup options...	See Warm up options menu
Booster start options	BP Start Options...	See Booster Pump Start options menu
Micro TIM options	Micro TIM...	See Micro TIM menu

Table A8 - Set sequences menu (continued)

Option	Text on PDT line 2	Options on PDT line 2 after pressing Enter (use up/down arrow to change, enter to select)
Dry Pump Clean	DP Clean...	See Dry Pump Clean menu
Allow pump to go on-process when in Warning	WarnOnProcess...	Enable/Disable
Ramped speed up on-process	OnProcessRamp...	See on-process Ramp menu
PID Pressure control setup	PID...	See PID menu
Smart Shutdown	Smart Stop...	See Smart Stop menu
Speed Control options	Speed Control...	See Speed Control menu
Reset MicroTIM	Reset MicroTIM...	See Reset MicroTIM menu
Restore factory defaults	Default Reset...	See Default Reset menu

Press the **UP/DOWN** keys to select the new settings and press **ENTER** to accept or **CANCEL** to exit back to the **Set sequences** menu.

A2.4.5.1 Warm up options menu

Scroll by pressing **UP/DOWN** keys. Press **ENTER** to open a sub menu or **CANCEL** to exit back to the **Set sequences** menu.

Table A9 - Warm up options menu

Option	Text on PDT line 2	Options on PDT line 2 after pressing Enter (use up/down arrow to change, enter to select)
Warm-up Temperature set point	Setpoint temp...	Range 0-210 °C *
Auto Green Mode	Auto Green Mode...	Enable/Disable
Allow Cold on-process	ColdOnProcess...	Enable/Disable
Inlet purge on during warm-up	Inlet Purge...	Enable/Disable
Automatically re-warm when in Green Mode	Auto Rewarm...	Enable/Disable

* Scroll through the temperature options by pressing the **UP/DOWN** keys. Press **ENTER** to accept the new setting. Press **CANCEL** to exit back into the **Warm up options** menu.

Press the **UP/DOWN** keys to select **enable / disable** and press **ENTER** to accept or **CANCEL** to exit back to the **Warm up options** menu.

A2.4.5.2 Booster pump start options menu

Scroll by pressing UP/DOWN keys. Press ENTER to open a sub menu or CANCEL to exit back to the Set sequences menu.

Table A10 - Booster pump start options menu

Option	Text on PDT line 2	Options on PDT line 2 after pressing Enter (use up/down arrow to change, enter to select)
Booster start mode	BP Start Mode	Select from: Manual Time Delay
Booster controller if in Time Delay Mode	BP delay after..	Select from: Dry pump Inlet isolation valve
Booster start delay	BP start delay..	Range 1-200 seconds*

* Scroll through the delay time options by pressing the UP/DOWN keys. Press ENTER to accept the new setting. Press CANCEL to exit back into the **Booster pump start options menu**.

Press the UP/DOWN keys to select the new settings and press ENTER to accept or CANCEL to exit back to the **Booster pump start options menu**.

A2.4.5.3 MicroTIM options menu

Scroll by pressing UP/DOWN keys. Press ENTER to open a sub menu or CANCEL to exit back to the Set sequences menu.

Table A11 - MicroTIM options menu

Option	Text on PDT line 2	Options on PDT line 2 after pressing Enter (use up/down arrow to change, enter to select)
Set MicroTIM Input 2	Input 2 ...	Select from: Green Mode Booster Isolation Valve PID Enable Second speed control
Set MicroTIM Output 4	Output 4 ...	Select from: Isolation Valve Warning Booster N2 Flow Water Flow Exhaust Pressure Control status On Process State Semicon Outputs

A2.4.5.4 DP clean menu

Scroll by pressing UP/DOWN keys. Press ENTER to open a sub menu or CANCEL to exit back to the Set sequences menu.

Table A12 - DP clean options menu

Option	Text on PDT line 2	Options on PDT line 2 after pressing Enter (use up/down arrow to change, enter to select)
Set clean speed	Set DP Speed...	Range 20 to 110 Hz*
Clean time	Clean Time...	Range 10 minutes to 60 minutes*
Automatically start on entering Green Mode	Start in Green Mode ...	Enable/Disable
Inlet purge open during clean cycle	Inlet Purge...	Enable/Disable
Inlet purge time after clean cycle	Purge Time	Range 0 minutes to 60 minutes*
Allow DP clean when pump is on process	Allow on Process	Enable/Disable
Automatically run DP clean during shutdown	Auto On Shutdown	Enable/Disable
Allow DP clean when pump is on process	Allow on Process	Enable/Disable
Automatically run DP clean during shutdown	Auto On Shutdown	Enable/Disable

* Scroll through the options by pressing the UP/DOWN keys. Press ENTER to accept the new setting. Press CANCEL to exit back into the DP clean menu.

Press the UP/DOWN keys to select enable / disable and press ENTER to accept or CANCEL to exit back to the DP clean menu.

A2.4.5.5 Warn on-process menu

Press the UP/DOWN keys to select enable / disable and press ENTER to accept or CANCEL to exit back to the Set sequences menu.

A2.4.5.6 On-process ramp menu

Scroll by pressing UP/DOWN keys. Press ENTER to open a sub menu or CANCEL to exit back to the Set sequences menu.

Table A13 - On-process ramp options menu

Option	Text on PDT line 2	Options on PDT line 2 after pressing Enter (use up/down arrow to change, enter to select)
Time between speed step changes	Ramp Time...	Range 0 - 3600 seconds in 60 second steps
Size of speed step changes	Ramp Step...	Range 5 to 110 Hz in Hz steps

Scroll through the options by pressing the UP/DOWN keys. Press ENTER to accept the new setting. Press CANCEL to exit back into the On-process ramp menu.

A2.4.5.7 PID menu

Scroll by pressing **UP/DOWN** keys. Press **ENTER** to open a sub menu or **CANCEL** to exit back to the **Set sequences** menu.

Table A14 - PID options menu

Option	Text on PDT line 2	Options on PDT line 2 after pressing Enter (use up/down arrow to change, enter to select)
PID enable/disable	Enable/Disable...	Enable/Disable
Pressure setpoint	Target Pressure	Range 1 to 10000 Pa [*]
PID operating mode	Operating mode...	Manual/Automatic
PID Tuning Parameters	PID Parameters...	See PID Parameters menu
Gauge used for PID	PID Gauge...	Active Gauge/Auxiliary Gauge/Pressure (4-20 mA)

^{*} For each digit press the **UP/DOWN** keys to set the digit then press **ENTER** to accept and move to the next digit or **CANCEL** to move back to the previous digit. Pressing **ENTER** at the end of the line will accept the new setting. Pressing **CANCEL** at the start of the line will cancel and exit back into the **PID** menu.

Press the **UP/DOWN** keys to select **enable / disable** and press **ENTER** to accept or **CANCEL** to exit back to the **PID** menu.

A2.4.5.8 PID parameters menu

Scroll by pressing **UP/DOWN** keys. Press **ENTER** to open a sub menu or **CANCEL** to exit back to the **PID** menu.

Table A15 - PID parameters options menu

Option	Text on PDT line 2	Options on PDT line 2 after pressing Enter (use up/down arrow to change, enter to select)
Time constant	Time Constant...	Range 0.01 - 10 seconds
Proportional constant	KC...	Floating point number
Integral constant	Ti...	Floating point number
Differential constant	Td...	Floating point number

For each digit press the **UP/DOWN** keys to set the digit then press **ENTER** to accept and move to the next digit or **CANCEL** to move back to the previous digit. Pressing **ENTER** at the end of the line will accept the new setting. Pressing **CANCEL** at the start of the line will cancel and exit back to the **PID parameters** menu.

A2.4.5.9 Smart stop menu

Scroll by pressing UP/DOWN keys. Press ENTER to open a sub menu or CANCEL to exit back to the Set sequences menu.

Table A16 - Smart stop options menu

Option	Text on PDT line 2	Options on PDT line 2 after pressing Enter (use up/down arrow to change, enter to select)
Smart stop enable/disable	Enable/Disable...	Enable/Disable
Time for pump to stop	Stop time...	Range 0 - 3600 seconds in 60 second steps*
Size of speed step changes	Step size...	Range 20 to 110 Hz*
Temperature to stop pump once reached	Setpoint...	Range 0-210 °C*
Time after temperature is reached before pump stops	Settle time...	Range 1-200 seconds*

* Scroll through the options by pressing the UP/DOWN keys. Press ENTER to accept the new setting. Press CANCEL to exit back into the Smart stop menu.

Press the UP/DOWN keys to select enable / disable and press ENTER to accept or CANCEL to exit back to the Smart stop menu.

A2.4.5.10 Speed control options menu

Scroll by pressing UP/DOWN keys. Press ENTER to open a sub menu or CANCEL to exit back to the Set sequences menu.

Table A17 - Speed control options menu

Option	Text on PDT line 2	Options on PDT line 2 after pressing Enter (use up/down arrow to change, enter to select)
Set speed control dry pump	Dry pump...	Select from: Normal/PID External Voltage SIM protocol Second speed
Set speed control booster	Booster...	Select from: Normal External Voltage SIM protocol Second speed
Set the second speed	Second Speed...	Range 20 - 110 Hz*

* Scroll through the options by pressing the UP/DOWN keys. Press ENTER to accept the new setting. Press CANCEL to exit back into the Speed control menu.

A2.4.5.11 Reset MicroTIM

Empties the MicroTIM configuration set storage of any configurations that have been loaded there.

A2.4.5.12 Default Reset

Resets all of the non volatile configuration settings on the pump (e.g.: delays, temperature setpoints and thresholds) to their default factory-setting values for that pump type.

A2.4.6 Display Inverter Fault History (DP Inv Fault Hist) menu

Under the **Setup** menu. Scroll by pressing **UP/DOWN** keys. Press **ENTER** to open a sub menu or **CANCEL** to exit back to the **Setup** menu.

Table A18 - Fault history menu

Fault history menu
DP Inv Fault Hist (Dry Pump Inverter Fault History)
MB Inv Fault Hist (Booster Inverter Fault History)

Each inverter fault history contains up to 32 entries, each contains one alarm and one warning, where 1 is the most recent. Scroll by pressing **UP/DOWN** keys. Press **CANCEL** to exit back to the **Inverter fault history** menu.

A2.4.7 Software version display menu

Under the **Setup** menu. Scroll through the software version loaded in the processors by pressing **UP/DOWN** keys. Press **CANCEL** to exit back to the **Setup** menu.

Table A19 - Software display menu

Software display menu
Executive...
Support...
DP Inverter...
DP Inverter 2...
MB Inverter...
DP Inv Params...
DP Inv2 Params...
MB Inv Params...

A2.4.8 Display serial number

Under the **Setup** menu. View the pump serial number. Press **CANCEL** to exit back to the **Setup** menu.

A2.4.9 Fit accessory menu

Under the **Setup** menu. Scroll by pressing **UP/DOWN** keys. Press **ENTER** to open a sub menu or **CANCEL** to exit back to the **Setup** menu. A security code is needed to enter the **Fit accessory** menus: 538.

Table A20 - Accessory menu

Accessory	Parameter
Isol Valve...	(Inlet isolation valve)
Water Sensor...	
Active gauge...	
N2 Flow Sensor...	(Purge gas flow)
Exh Pressure...	(Exhaust Pressure Sensor)
DP Clean...	
Auxiliary gauge...	Choice of Voltage/Strain Gauge/Pirani Gauge
PT100 1...	
PT100 2...	
Pressure...	
Pressure 2...	
Max pressure 1...	xxxxmbar
Max Pressure 2...	xxxxmbar
Gas Ballast...	(Additional gas ballast for GXS450 and GXS750 systems fitted with the medium duty gas module only)

For an accessory press the **UP/DOWN** keys to select **Fitted** or **Not Fitted** and press **ENTER** to accept or **CANCEL** to exit back to the **Commands** menu.

Note: Inlet isolation valves additionally have an option of fitted no feedback for use where there are no position feedback switches fitted to the inlet isolation valve.

A2.4.10 IP configuration menu

Under the **Setup** menu. Scroll by pressing **UP/DOWN** keys. Press **ENTER** to open a sub menu or **CANCEL** to exit back to the **Setup** menu.

Table A21 - Configuration menu

Configuration	Display
Host_Name...	(display only)
DHCP Enable...	(Enabled / Disabled)*
IP Address...	(xxx.xxx.xxx.xxx) [†]
Address Mask...	(xxx.xxx.xxx.xxx) [†]
Gateway...	(xxx.xxx.xxx.xxx) [†]
DNS Server...	(xxx.xxx.xxx.xxx) [†]
NTP Server...	(display only)
SMTP Server...	(display only)
MAC Address...	(display only)
Domain Name...	(display only)

* Press the **UP/DOWN** keys to select **Enabled** or **Disabled** and press **ENTER** to accept or **CANCEL** to exit back to the **IP configuration** menu.

[†] For each address setting press the **UP/DOWN** keys to set the digit, press **ENTER** to accept and move to the next digit or **CANCEL** to move back to the previous digit. Pressing **ENTER** at the end of the line will accept the new setting and exit back to the **Edit IP** menu. Pressing **CANCEL** at the start of the line will cancel and exit back to the **IP configuration** menu.

Display only items press **CANCEL** to exit back to the **IP configuration** menu.

A2.4.11 Display menu

Under the **Setup** menu. Scroll by pressing **UP/DOWN** keys. Press **ENTER** to open a sub menu or **CANCEL** to exit back to the **Setup** menu.

Table A22 - Display menu

Display
Units...
Normal display (Selects the parameters displayed in Normal)
Auto Scroll
Scroll Delay

UNITS (units to display)

Scroll by pressing **UP/DOWN** keys. Press **ENTER** to open a sub menu or **CANCEL** to exit back to the **Display attributes** menu.

Table A23 - Units

Parameter	Key
Pressure...	(PSI/kPa/mbar)
Temperature...	(Centigrade/Fahrenheit/Kelvin)
Speed...	(rpm/Hz)
Active Gauge...	(mBar/Torr/kPA)

In each option scroll through the units available by pressing **UP/DOWN** keys. Press **ENTER** to select the displayed units or **CANCEL** to exit back to the **Units** menu.

SELECT LINE (Normal display selection menu)

Scroll by pressing **UP/DOWN** keys. Press **ENTER** to open a sub menu or **CANCEL** to exit back to the **Display attributes** menu.

Table A24 - Selection menu

Parameter
Top Page 1...
Bottom Page 1...
Top Page 2...
Bottom Page 2...

In each option the select parameter menu is opened, scroll through the parameters by pressing **UP/DOWN** keys. Press **ENTER** to select the parameter for display or **CANCEL** to exit back to the **Select line** menu.

A2.4.12 Set clock

Under the **Setup** menu. Press **ENTER** to change the date and time displayed or press **CANCEL** to exit back to the **Setup** menu.

For each digit setting press the **UP/DOWN** keys to set the digit, press **ENTER** to accept and move to the next digit or **CANCEL** to move back to the previous digit. Pressing **ENTER** at the end of the line will accept the new setting and exit back to the **Set Clock** menu. Pressing **CANCEL** at the start of the line will cancel and exit back to the **Setup** menu.

A2.5 How to set up the PDT display

The configuration options for the PDT are stored in the PDT itself and are not associated with the pump that the PDT is connected to. This means a user can transfer a PDT between pumps and keep the same settings. It also means that different units could be displayed on two PDTs connected to the same pump.

The following PDT menus are used to configure the PDT display.

Figure A42 - PDT menu items

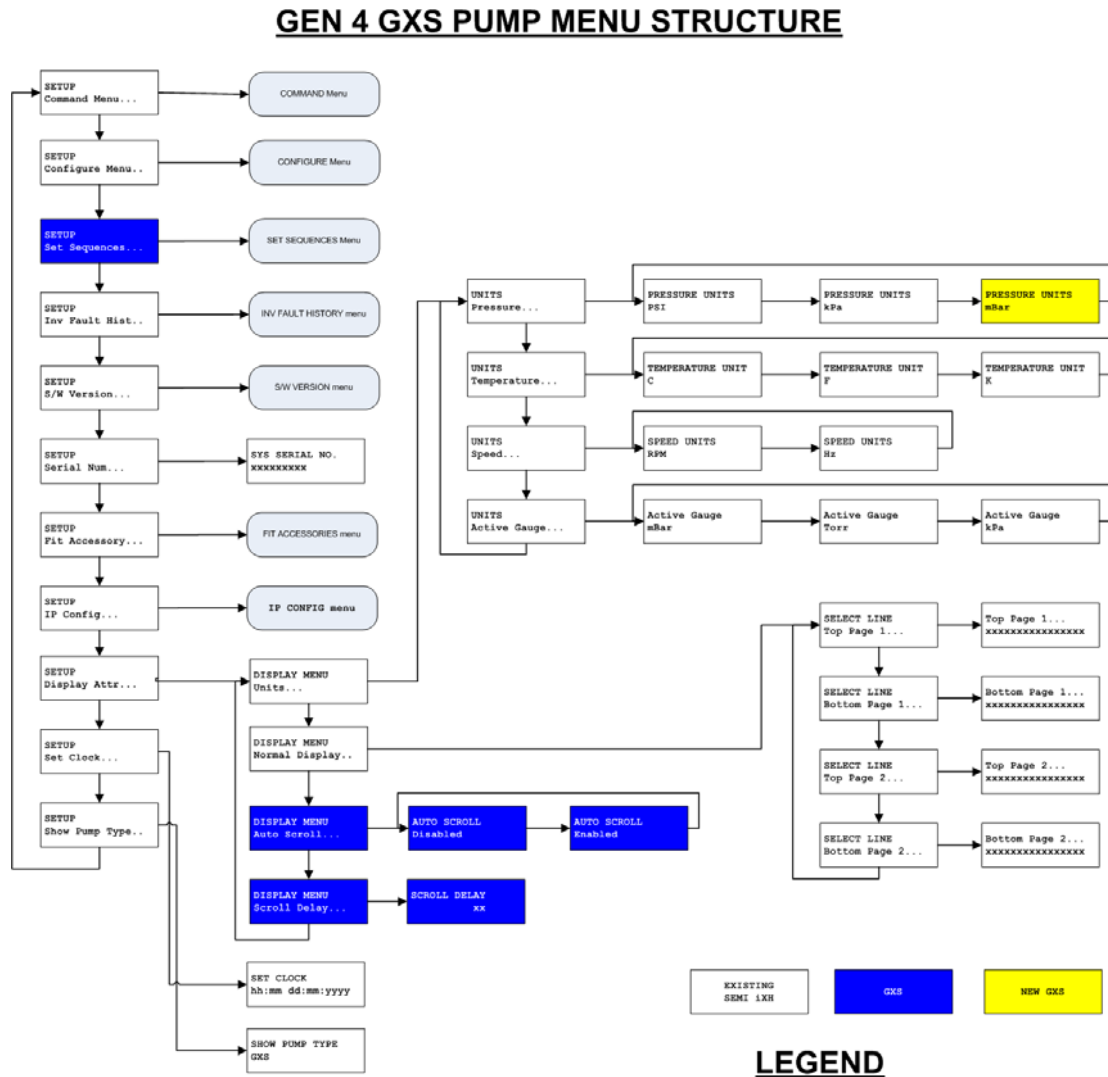

A2.5.1 Setting the status screen to automatically scroll

The GXS status display can be made to automatically scroll through its display items using the **auto scroll** menu item. The delay between refreshes is set using the **scroll delay** menu item.

A2.5.2 Change the normal menu display

The normal display on the PDT can be customized to display any status item. The normal display consists of 2 pages each of 2 lines so there are 4 configurable lines. When in the select parameter menu the bottom line of the display shows what will be displayed if that option was selected.

A2.6 How to configure the pump warm-up options

By default the GXS pump performs an intelligent warm-up cycle to a temperature set point so that the pump is warm before it is allowed to be on-process. Once the pump reaches the temperature set point it automatically goes on-process.

If the pump is no longer to be on-process a choice can be made to either stop the pump or put it into Green Mode/ Standby mode.

If the pump is in Green Mode/Standby mode it can either be put on-process or stopped.

It is possible to change the behaviour of the GXS pump using the PDT. The following menus are used by the PDT to configure warm-up.

Figure A43 - Warm-up PDT menu items

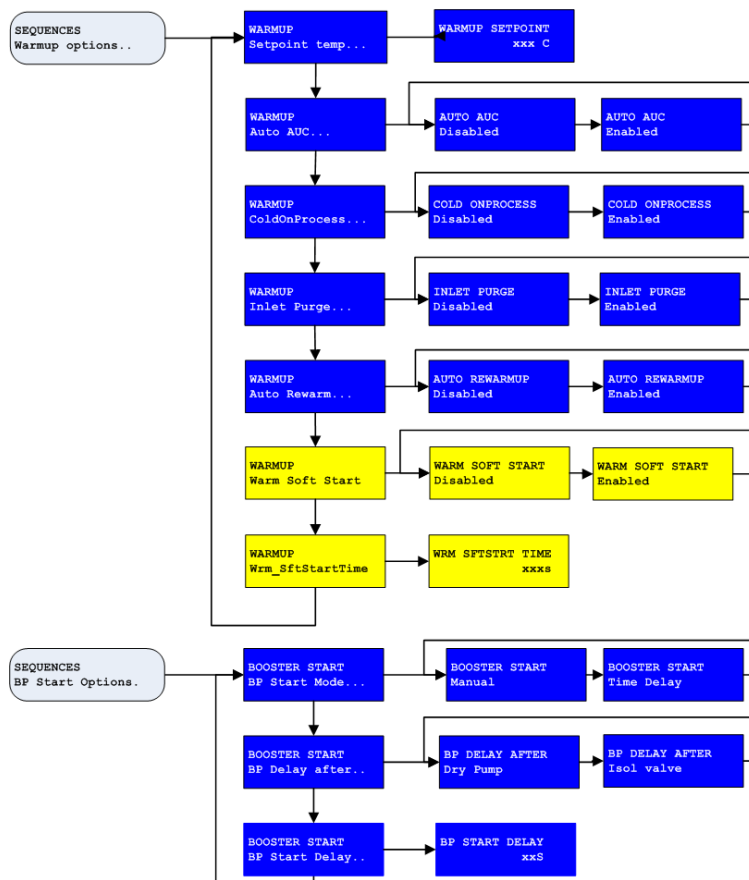

A2.6.1 Lowering the warm-up temperature

Use the **warmup setpoint temp** menu item and decrease the warm up set point to the desired temperature. The minimum temperature allowed is 0 °C.

A2.6.2 Disabling warm-up cycle

It may be required for the pump to skip the warm-up cycle and go directly on-process once it has reached full speed. There are two ways to achieve this:

- Enable COLD ONPROCESS
- Adjust the WARMUP Setpoint temp set point to below ambient temperature.

A2.6.3 Increasing the warm-up temperature

Use the **Warmup setpoint temp** menu item and increase the warm up set point to the desired temperature to suit your application.

Note: The maximum temperature allowed for warmup setpoint temp is above the alarm limit for the pump so if the temperature is set too high the pump will never warm up. Changing the warm-up temperature does not change the pump's water cooling operation. This is fixed by Edwards and can only be changed by a downloadable configuration.

A2.6.4 Stop the pump going on-process when it is warm

The GXS pump can be configured to automatically go into Green Mode/Standby mode when it is warm instead of going on-process. To do this, go to the **Auto Green Mode** menu and disable auto Green Mode.

Note: If the pump is controlled by a tool interface then the pump will follow the state of the on-process line.

A2.6.5 Stop the pump automatically warming up when in Green Mode / standby mode

If the pump is running in Green Mode/Standby mode and its internal temperature drops below the warm-up set point then by default the pump will automatically perform a warm up cycle. This could result in the pump speeding up and slowing down over a period of time.

If the application does not require the pump to remain above the warm-up set point whilst in Green Mode/Standby mode then automatic re-warming can be disabled using the **Warmup auto rewarm** menu item.

A2.6.6 Turn inlet purge on during warm-up

A pump can be made to warm up more quickly by adding inlet purge during the warm up cycle. This is enabled using the **Inlet purge** menu item.

Note: Systems with the light duty gas module do not have inlet purge so it is not possible to use this feature.

A2.6.7 Allow a pump to go on-process with a warning

By default a pump is prevented from going on-process if a warning is present. This can be disabled using the **Warn onprocess** menu item which can be found by going to the **Setup** menu and selecting the **Set sequences** menu.

A2.6.8 Warm soft start

This enables a feature where, once warmed up to go on process, the pump is returned to the off process speed for a configurable time period ("WrmSftStartTime") before it goes on process.

A2.7 How to configure the booster pump behaviour

By default the GXS booster pump starts a set time after the GXS dry pump starts. The booster stops at the same time as the GXS dry pump.

It is possible to change the behaviour of the booster pump so that it can be controlled manually or so that the time delay can be changed or that it starts after the inlet isolation valve is open.

Note: A GXS pump with a tool interface can control the booster independently. See [Appendix A2.14.1](#) for details on configuring this behaviour.

The following menus are used by the PDT to configure the booster:

Figure A44 - Booster PDT menu configuration items

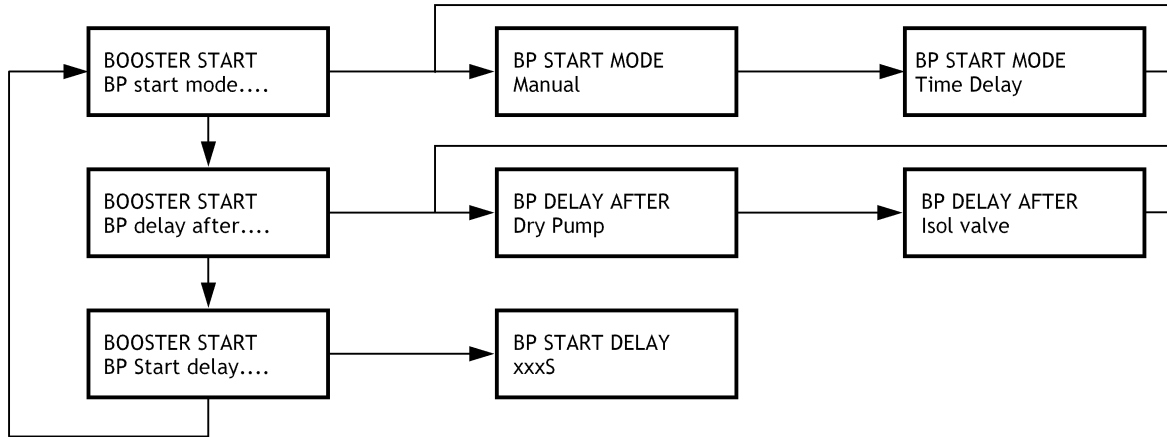

dcs/8651/029

A2.7.1 Setting the booster to manual operation

The booster can be set to manual mode using the **BP Start mode** menu item.

1. From the **SETUP** menu, scroll down and select the **Set Sequences** menu.
2. Scroll down and select **BP Start Options**.
3. Select **BP Start Mode...**
4. Select **Manual**.

The booster can then be started and stopped using the **MB** menu item from the **Commands** menu. Refer to [Section A2.15](#).

Note: If a booster is manually controlled and the dry pump is stopped then the booster will continue running.

A2.7.2 Changing the booster time delay

The time delay for starting the booster in automatic mode can be configured using the **BP start delay** menu item to between 1 and 200 seconds.

Note: It is not recommended to set the delay to less than 20 seconds when the booster is starting after the dry pump.

A2.7.3 Setting the booster to start when the inlet isolation valve is open

To reduce energy consumption the booster can be configured to only run when the inlet isolation valve is open. The inlet isolation valve automatically opens when the dry pump is on-process and is closed in Green Mode/Standby mode.

To configure the booster to only be on when the inlet isolation valve is open use the **BP delay after** menu item and set the option to **Isol valve**.

A2.8 How to configure pump behaviour

A2.8.1 Smart stop

The GXS pump has a configurable intelligent shut down behaviour mode called Smart Stop. When Smart Stop is enabled the speed of the pump is ramped down gradually to allow the pump to cool down before stopping. The intention is to allow condensable process chemicals to be pumped away without jamming the pump mechanism.

The following flow chart shows how Smart Stop operates:

Figure A45 - Smart stop flow chart

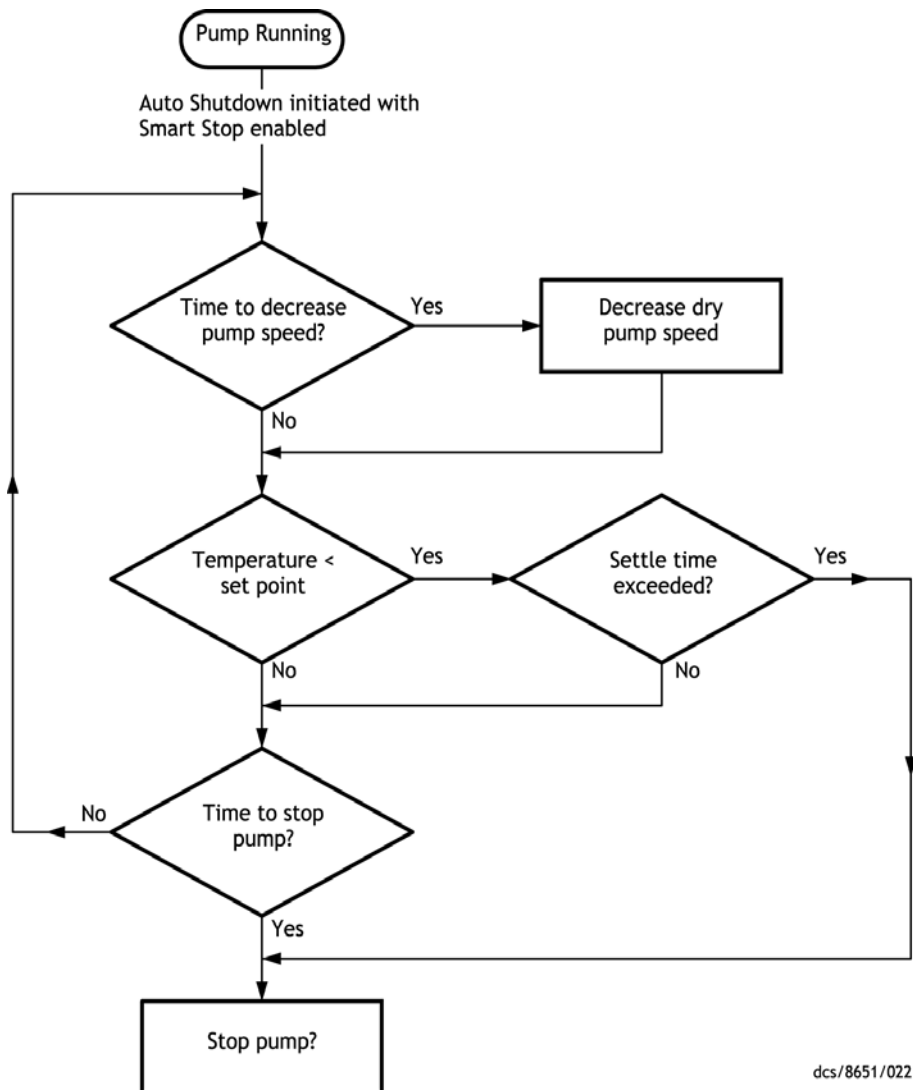

The following menus are used by the PDT to configure Smart stop:

Figure A46 - Smart stop PDT menu configuration items

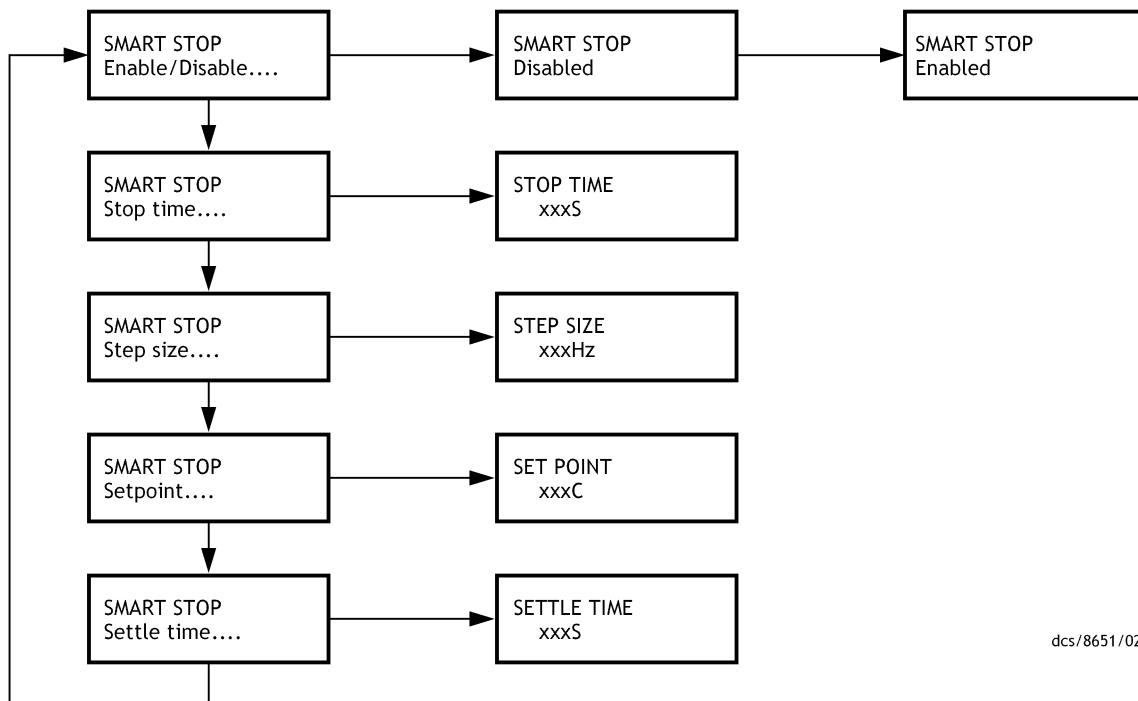

dcs/8651/023

- Smart Stop is enabled and disabled using the **enable/disable** menu item.
- The maximum time that the pump will run whilst shutting down is set using the **Stop time** menu item.
- The size of the dry pump speed reductions is configured using the **Step size** menu item. The time between speed step reductions is automatically calculated by the software based on the size of the speed step reductions and the maximum time the pump will run.
- The pump can be triggered to stop when its internal temperature reaches a certain set point. Select the **Setpoint** menu to configure the set point temperature.
- The pump can be triggered to stop a certain time period after it has cooled to the set point temperature. Select the **Settle time** menu to adjust the time period.

A2.8.2 How to configure ramped speed increase

The GXS pump has a configurable intelligent on-process behaviour mode called on-process Ramp. When on-process Ramp is enabled the speed of the pump is ramped up gradually when accelerating from Green Mode/Standby speed to process speed. This gradual acceleration can prevent a large disturbance to the process load which could result in a slug of process material being drawn into the pump.

Note: On-Process Ramp is only effective if an Green Mode/Standby speed of less than full speed has been set. Contact Edwards for more information about configuring Green Mode/Standby speed.

The following menus are used by the PDT to on-process Ramp:

Figure A47 - On-process ramp PDT menu configuration items

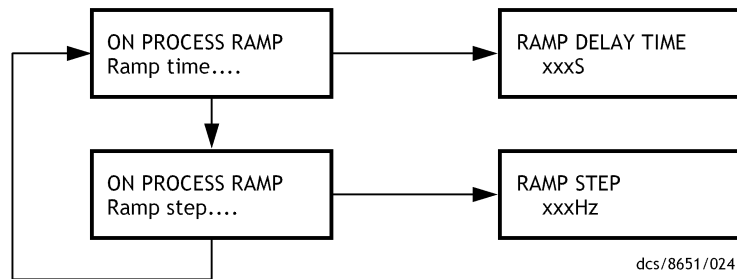

On-process Ramp is enabled by setting a ramp delay time greater than zero. This time is the time delay between pump speed increases. The ramp step size determines the size of each step. Pump speed will not exceed the maximum allowed pump speed.

A2.9 How to set up DP clean

The DP clean set sequence can be used to clean the dry pump of GXS systems that are fitted with the high flow purge and solvent flush kit.

Before using DP clean, ensure that the high flow purge and solvent flush kit is set up as described in [Section 3.14](#). Refer also to [Section 4.9](#).

The DP clean process is run while the dry pump is in Green Mode / standby mode. By default DP Clean runs for 20 minutes with the dry pump running at 80 Hz with no inlet purge.

The following flow chart shows the functional behaviour of dry pump clean:

Figure A48 - Dry pump clean flow chart

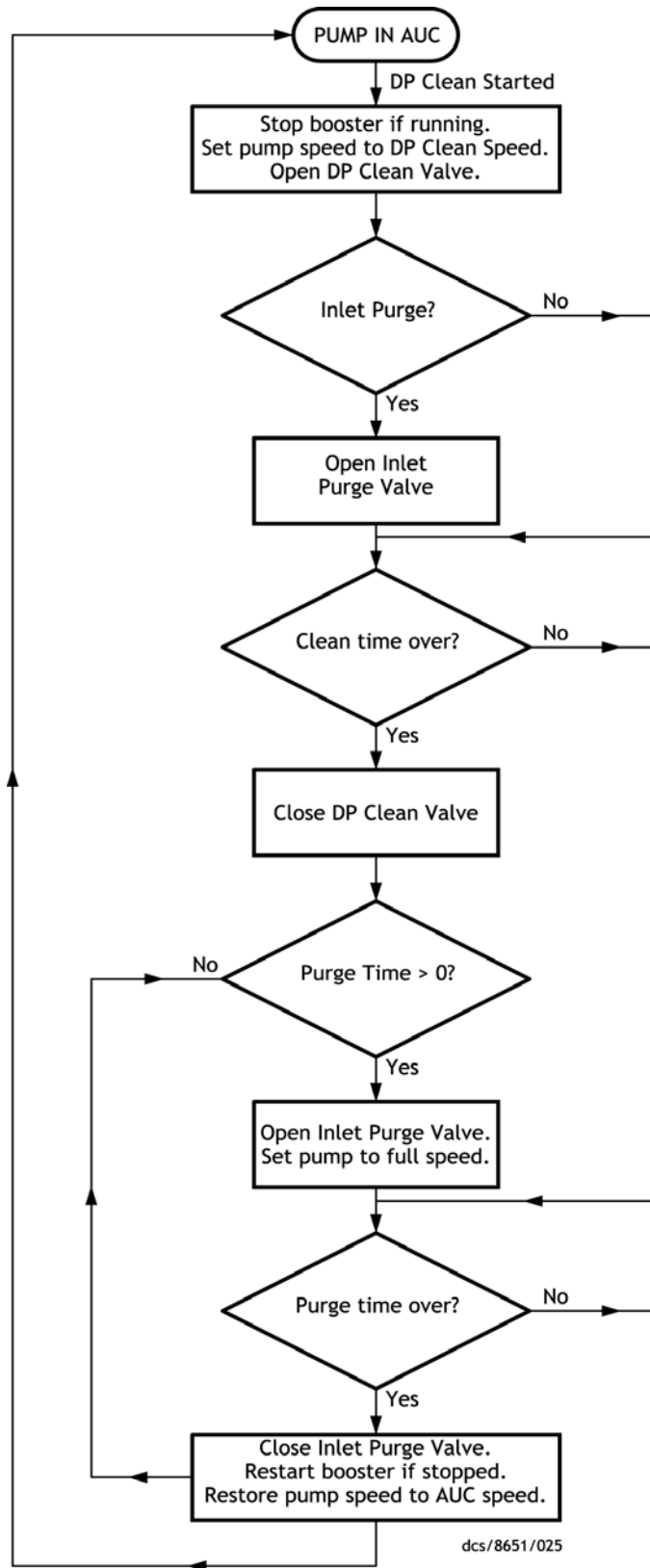

The following menus are used by the PDT to configure dry pump clean:

Figure A49 - Dry pump clean PDT menu configuration items

**GEN 4 GXS PUMP MENU STRUCTURE –
SET SEQUENCES**

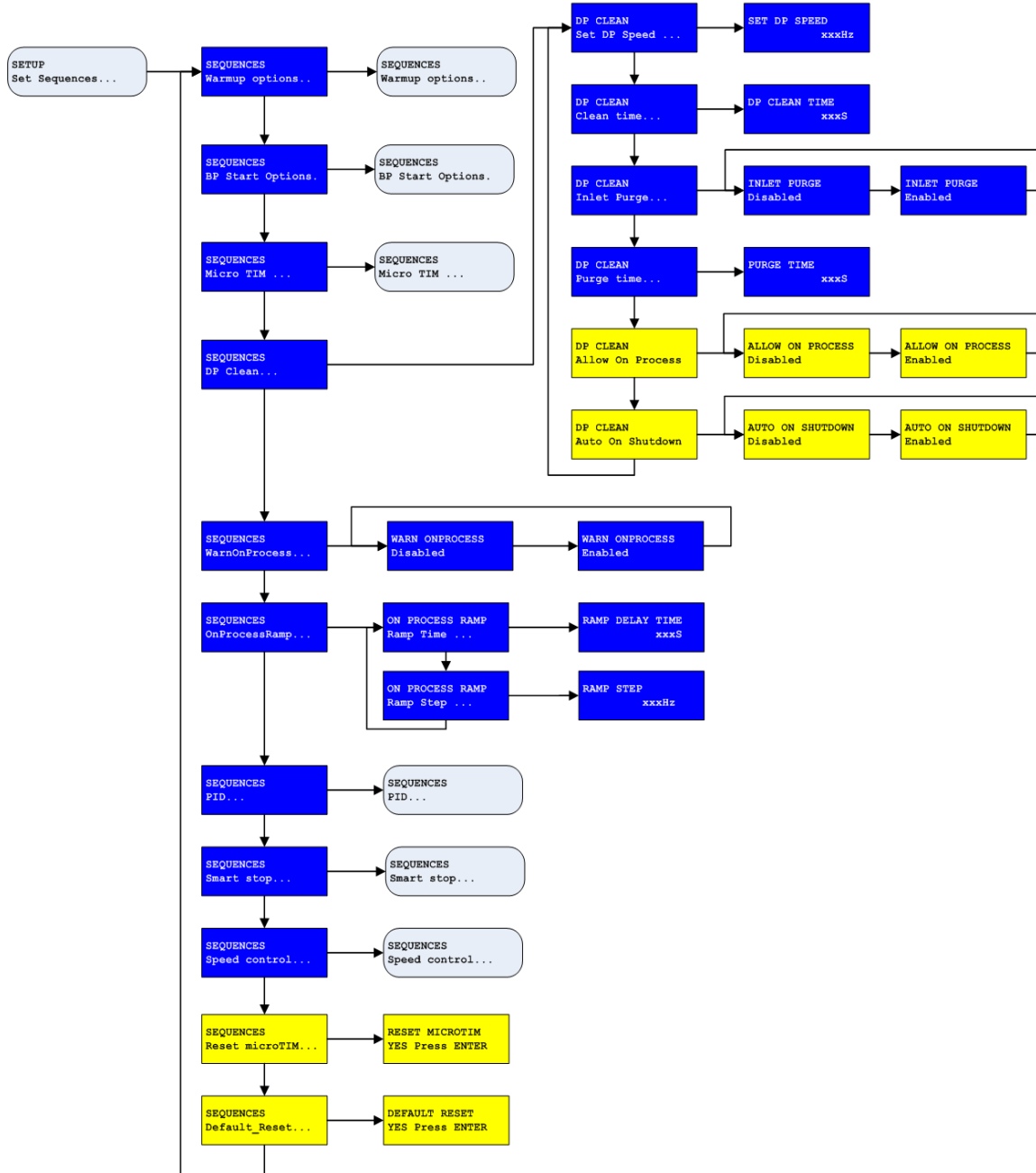

A2.9.1 Changing the dry pump speed during the clean operation

Use the **Set DP speed** menu item to change the dry pump speed during the clean cycle. It is not recommended to increase the pump speed if solvent is used. If the dry pump clean is just using air then setting the speed to 110 Hz would increase the efficiency of the cleaning cycle.

A2.9.2 Changing the clean cycle time

The time period for the dry pump clean cycle can be changed using the **DP clean time** menu item.

A2.9.3 Automatically initiating a clean cycle when the pump goes off-process

The dry pump can be configured to automatically start a dry pump clean cycle when it goes off-process. This is useful if the pump requires regular cleaning on a particularly dirty process. This mode is enabled by setting enable in the **Start in Green Mode** menu item.

A2.9.4 Turn inlet purge on during the clean cycle

To increase the gas flow through the dry pump during a clean cycle it is possible to configure the inlet purge gas valve to be open during the clean cycle. This mode is enabled by setting enable in the **Inlet purge** menu item.

A2.9.5 Have inlet purge cycle after clean cycle

For some processes it is desirable to ensure that the pump is both fully dry and internally warm after a clean cycle has been completed. The GXS pump can be configured to have an optional inlet purge cycle where the pump runs at full speed. To enable this option, use the **Purge time** menu item and set the purge time to a value greater than zero.

A2.9.6 Allow on process

Allows a DP Clean to start while the pump is on process.

A2.9.7 Auto on shutdown

When enabled, a DP clean cycle occurs every pump auto shutdown.

A2.10 How to control pump speed

By default, both the dry pump and booster run at full speed whilst the pump is on-process. For some applications it is advantageous to adjust the speed of the pump whilst it is on-process so GXS has the capability to run both the dry pump and booster at various different speeds.

The speeds of the dry pump and booster can be controlled using a number of different methods as shown in [Table A25](#).

Table A25 - Speed control sources

Speed control sources:
Normal speed (default)
External voltage 0 - 10 V input *
SIM protocol over one of the serial RS232 interfaces
SIM protocol over the Ethernet interface
As a second speed controlled from the PDT*
As a second speed controlled from the MCM MicroTIM*
Profibus interface

* Only one of the pumps (dry pump or booster) can be controlled by this at one time, although the other pump can be controlled by a different source.

Note: The GXS also has a built-in PID controller, refer to [Appendix A2.11](#) for more information.

The PDT menus for speed control are shown in Figure A50.

Figure A50 - Speed control menu items

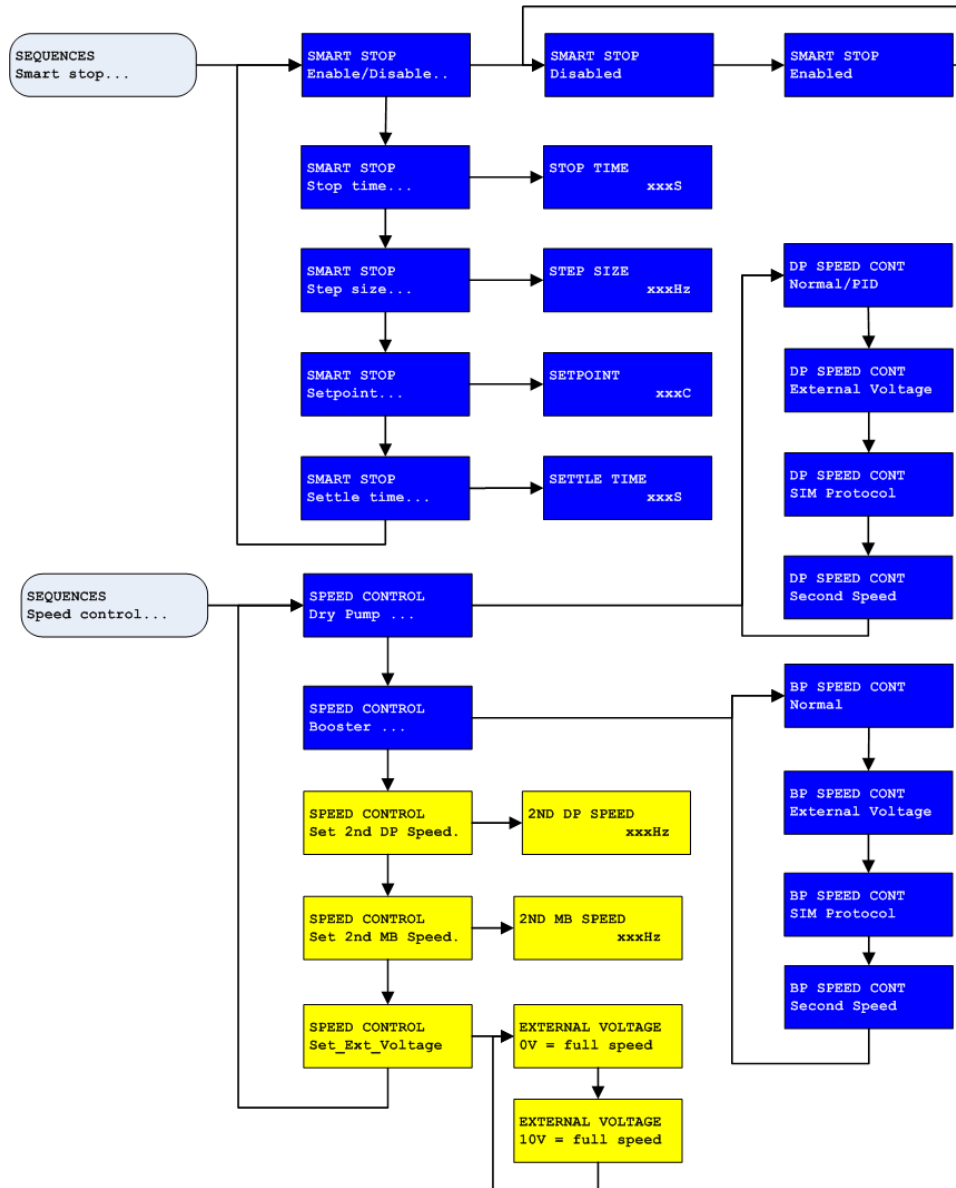

A2.10.1 Normal speed

The full speed settings for the booster and dry pump are set by Edwards when the pump is manufactured. If a lower full speed is required then this can be set using a downloadable configuration. Configurations can be downloaded using the Edwards Configuration Download Utility (CDU). Please contact Edwards application specialists to discuss your requirements.

By default, dry pump and booster speed control are set to normal, meaning that the pumps will run at their configured full speeds.

A2.10.2 External voltage

The auxiliary gauge input on the rear of the GXS (available as an optional accessory, shown in [Figure 3](#), item 14) can be used as a 0 - 10 V speed control for either the dry pump or the booster. The connector is a standard RJ45, refer to [Figure A51](#) to identify the pin numbers. Use pin 3 for the external voltage signal and pin 5 for signal common.

Figure A51 - Pin numbers on the auxiliary gauge interface

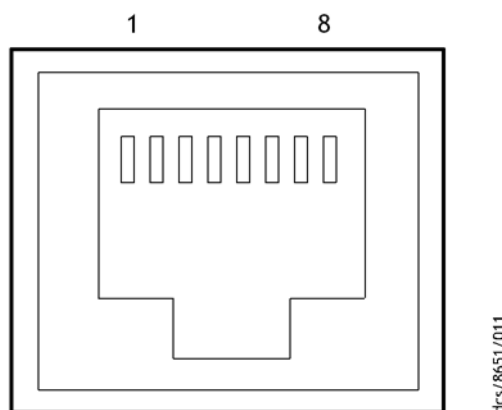

The 0-10V input is scaled linearly and may be configured such that the pump runs at 100% speed when the input voltage is either 0V or 10V. The pump speed may be decreased to 20Hz by increasing / decreasing the supply voltage depending on the external voltage speed control configuration.

Note: *If the cable becomes disconnected, the pump will run at full speed.*

To enable external voltage as the speed control source, use the PDT to select external voltage for the appropriate pump.

A2.10.3 SIM protocol

It is possible to independently control the speed of both the dry pump and the booster using the built-in SIM protocol. Refer to the SIM Protocol Manual (P411-00-200) for details of the commands to use.

The GXS supports the SIM protocol by both the Ethernet and the serial ports. Refer to [Appendix A2.12](#) for information about setting up the Ethernet interface and to [Appendix A2.13](#) for details of how to use SIM protocol with a serial port.

A2.10.4 Second speed control

A second speed setting can be configured using the PDT and used to control the speed of either the booster or the dry pump.

The second speed setting can be enabled and disabled using the PDT from the **Command** menu, using the SIM protocol or the MCM MicroTIM configured for speed control. Refer to [Appendix A2.14](#) for information how to configure the MicroTIM.

A2.10.5 Profibus interface

It is possible to independently control the speed of both the dry pump and the booster using the optional Profibus interface, available as an accessory. For more information, refer to the GXS Profibus instruction manual D397-53-880. The GSD file is available from Edwards.

If using Profibus, ensure that speed control is set to normal (default setting) for both the pump and booster.

A2.11 How to use PID pressure control

The GXS pump has a built in PID pressure control and auto tune feature that can adjust the GXS dry pump speed when the pump is on-process so that the pressure reading of a pressure sensor matches the supplied PID set point. Edwards recommend that the PID is auto tuned after the PID set point is adjusted.

Figure A52 - The simplified system diagram

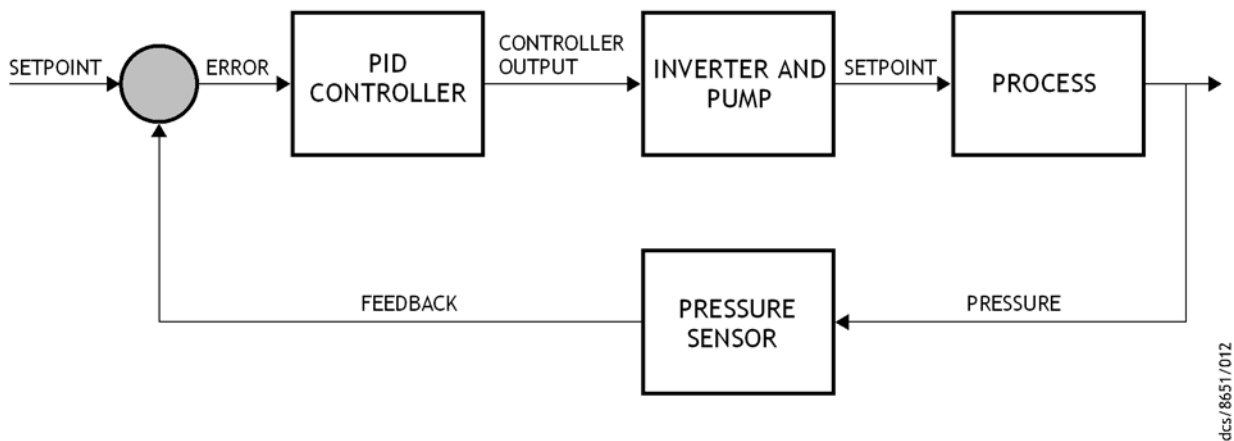

dcs/8651/012

Classical PID equation

$$u(t) = K_c \left(e(t) + \frac{1}{T_i} \int_0^t e(\tau) d\tau + T_d \frac{de(t)}{dt} \right) + b$$

Where:

u is the control signal.

e is the control error.

K_c is the gain for a proportional controller.

T_i is the parameter that scales the integral controller.

T_d is the parameter that scales the derivative controller.

t is the time taken for error measurement.

b is the set point value of the signal, also known as bias or offset.

On a GXS pump the K_c , T_i and T_d parameters and the time constant can either be set by the user or the pump can perform an auto tune that calculates these parameters based on the response of the system at the setpoint pressure.

The GXS pump PID pressure control sequence is designed to work with an Edwards strain gauge or Edwards active Pirani gauge (available as accessories). Due to inaccuracies in the gauges, Edwards do not recommend trying to control below 20 mbar with a strain gauge. Refer to [Appendix A2.11.2](#) to use a different pressure sensor.

The following menus are used by the PDT to configure and use the PID functionality.

Figure A53 - PID PDT menu items

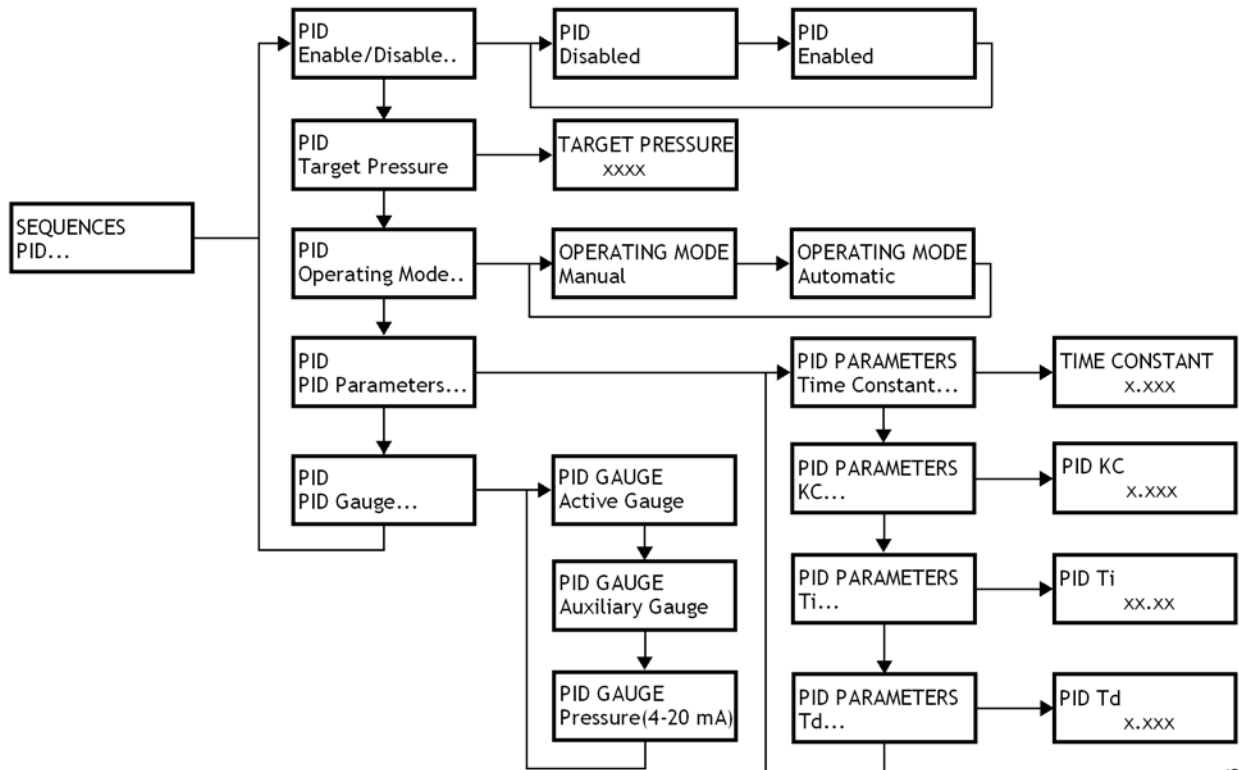

dcsl/8651/005

To set up PID follow these steps:

A2.11.1 Fit and configure the pressure sensor

1. Fit the GXS auxiliary gauge cable accessory following the instructions given in the installation manual supplied with the accessory.
2. Physically fit the active strain gauge or active Pirani gauge to a convenient port on the process chamber.
3. Connect the gauge into the auxiliary gauge connector on the GXS back panel, refer to [Figure 3](#), item 14.
4. From the **Fit accessory** menu choose **Auxiliary Gauge** and then select the appropriate gauge from the list.
5. From the **Setup** menu select **Set sequences**.
6. From the **Sequences** menu, select **PID...**
7. From the **PID** menu, select **PID gauge...**
8. From the **PID gauge** menu, select **Auxiliary gauge**.

You can also use a different gauge as the PID gauge, refer to [Appendix A2.11.2](#).

A2.11.2 Using a different gauge

It is possible to configure the PID settings so that a different pressure gauge is used as the PID gauge.

If an Edwards Active Accessories Module (AAM) is fitted to the pump (available as an accessory, refer to [Section 7.3](#)) an active gauge can be connected to it and used the same as a PID gauge.

1. Fit the gauge to an appropriate port on your system.
2. Connect the gauge to the Active Accessories Module.
3. From the **Fit accessory** menu select **Active gauge** to **Fitted**.
4. From the **Setup** menu select **Set sequences**.
5. From the **Sequences** menu, select **PID...**
6. From the **PID** menu, select **PID gauge...**
7. From the **PID gauge** menu, select **Active gauge**.

A pressure gauge can also be used that has a 4 - 20 mA signal output. To use a gauge of this type a GXS pressure input cable (4 - 20 mA) and associated connector kit will need to be purchased which are available as accessories, refer to [Section 7.3](#).

1. Fit the GXS pressure input cable accessory following the instructions given in the installation manual supplied with the accessory.
2. Fit the connector kit onto the cable on the pressure gauge.
3. Connect the gauge to the pressure input connection on the rear of the GXS (Figure 3, item 14)
4. From the **Fit accessory** menu select **Pressure** to **Fitted**.
5. From the **Setup** menu select **Set sequences**.
6. From the **Set sequences** menu, select **PID...**
7. From the **PID gauge** menu, select **Pressure (4 - 20mA)**.

A2.11.3 Set pump into Green Mode mode

1. Start the GXS dry pump using the PDT and let it warm up.
2. Check on the **Status** display that there is a pressure reading for "AG x.xxExx mbar" and that the reading is what you expect for the chamber.
3. Set the GXS into Green Mode mode using the **Commands** menu option.

A2.11.4 Enable PID

1. From the **Setup** menu select **Set sequences**.
2. From the **Sequences** menu select **PID**.
3. From the **PID** menu select **enable/disable** and then set **PID to enabled**.

A2.11.5 Set the PID target pressure set point

From the **PID** menu select **Target pressure** and enter the desired control pressure in Pa. For each digit of the target pressure value press the up/down keys to set the digit then press **ENTER** to accept and move to the next digit or **CANCEL** to move back to the previous digit. Pressing **ENTER** at the end of the line will accept the new setting. Pressing **CANCEL** at the start of the line will cancel and exit back into the **PID** menu.

The PID target pressure set point can also be configured using a voltage signal. For further details please contact Edwards.

A2.11.6 Test the PID control

1. If the booster is under manual control, ensure that it is switched on and running.
2. Turn Green Mode off from the **Command** menu.
3. PID should now start automatically. If it does not start to control the inlet pressure use the PDT and go to **Setup / Command / PID / On**.

A2.11.7 Auto tune the PID

PID Auto Tune should not be used.

A2.11.8 Manually tuning the PID

Use the following default PID parameters:

$T_c = 1$

$K_c = 0.01$ (increasing the value results in a faster time to target pressure. 0.02 is generally the largest value required)

$T_i = 50$ (decreasing the value results in a faster time to target pressure. 20 is generally the smallest value required)

$T_d = 0.0001$

Do not change T_c or T_d

PID parameters are accessed using the PDT - go to **Setup / Set sequences / PID / PID parameters**.

A2.11.9 Turning PID on and off when on-process

The MCM MicroTIM or the PDT can be used to turn PID on and off when the pump is on-process by configuring the PID to manual operating mode. This can be useful when a pump down to base pressure is required before pressure control is initiated.

1. From the **PID** menu, select **Operating mode...**
2. From the **Operating mode** menu, select **Manual**.

Refer to the MCM MicroTIM manual and [Appendix A2.14](#) for information about using the MCM MicroTIM to enable PID.

A2.12 How to set up the Ethernet port

The GXS pump has a single 10baseT Ethernet port that can be configured in either static address mode or DHCP mode. There are a variety of protocols that can be run over the Ethernet port including HTTP Web pages, Fabworks EtherNim, SIM and E54 Modbus.

The web server and SIM protocols are the only protocols available for users. The web server is enabled automatically when the Ethernet port is operational. The manual for SIM protocol is P411-00-200. If you wish to use the Ethernet port with different protocols then contact Edwards.

Before the Ethernet connection is used it requires a valid IP address. Set the IP address using the PDT. Both static IP addressing and DHCP dynamic addressing are supported by the pumps.

Note: *If the GXS pump is set to DHCP mode it will not be visible through a router. If operation through a router is required then use static address mode. The GXS pump does not require NTP, DNS or SMTP server addresses to be set to function correctly. A gateway address is only required if working with a router. If working in static address mode then you need to provide the IP address, the address mask and the gateway address.*

The following menus are used by the PDT to configure the Ethernet port:

Figure A54 - Ethernet menu items

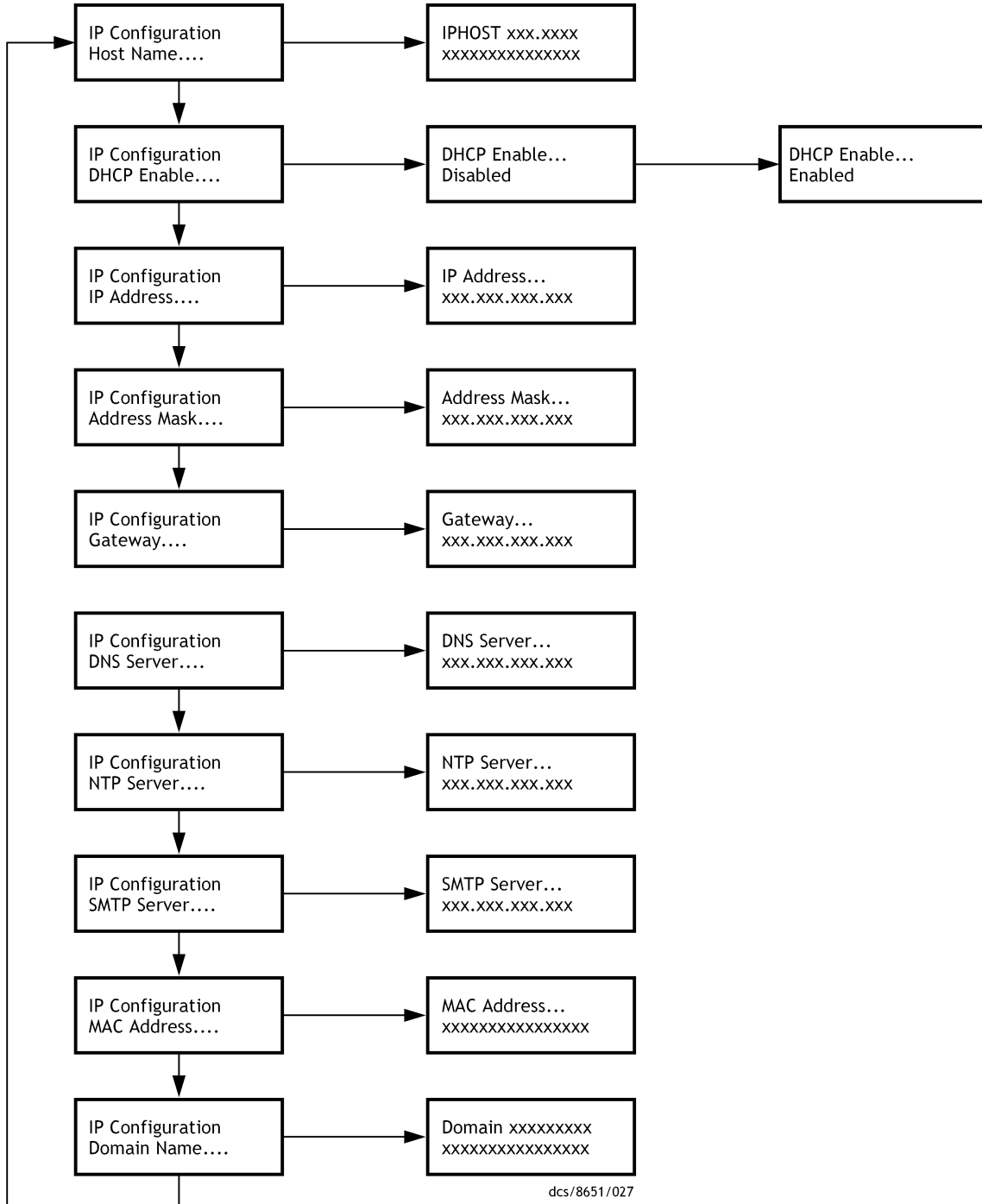

A2.12.1 Using SIM protocol through Ethernet

The SIM Ethernet protocol is available on the following TCP/IP Ports

Table A26 - SIM protocol

SIM	TCP/IP Port
1	47591
2	47592

Use an Ethernet cable to connect to the Ethernet interface (Figure 3, item 3) and then set the IP address of the system to the correct address.

Note: If changing the IP address of a system or connecting/disconnecting an Ethernet cable, it may take several minutes before the GXS responds on its Ethernet port.

When the GXS system is configured to use DHCP addressing the PDT can be used to read the pump's current IP address. The Setup menu to display this is shown below.

Figure A55 - Setup menu items

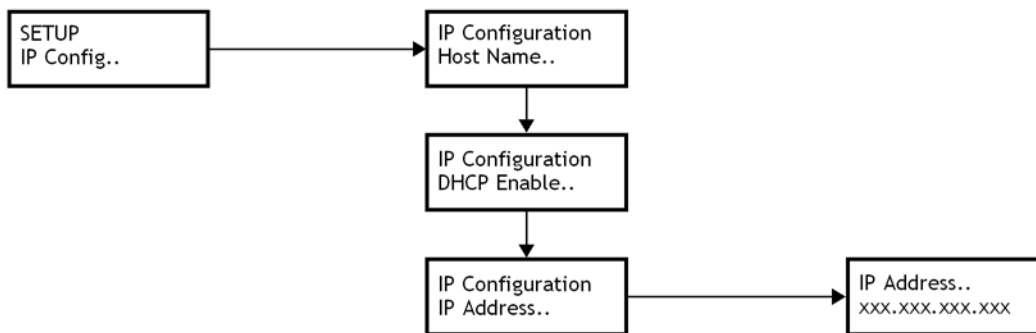

dcs/8651/002

To check that communication with the GXS is working, use the ping command from a command prompt on the computer. It is important that the GXS and the computer are able to route signals to each other, for example they should be on the same subnet. If in doubt contact the computer support department for advice.

Example of ping to a pump:

Figure A56 - Ping to a pump screenshot

```

c:\WINDOWS\system32\cmd.exe
C:\>ping 160.100.31.213

Pinging 160.100.31.213 with 32 bytes of data:

Reply from 160.100.31.213: bytes=32 time=8ms TTL=255
Reply from 160.100.31.213: bytes=32 time=13ms TTL=255
Reply from 160.100.31.213: bytes=32 time=21ms TTL=255
Reply from 160.100.31.213: bytes=32 time=5ms TTL=255

Ping statistics for 160.100.31.213:
    Packets: Sent = 4, Received = 4, Lost = 0 (0% loss),
    Approximate round trip times in milli-seconds:
        Minimum = 5ms, Maximum = 21ms, Average = 11ms

C:\>_
  
```

dcs/8651/003

SIM protocol can be tested over Ethernet using HyperTerminal.

1. Start HyperTerminal.
2. Enter the IP address of the pump in the Host address field. In the Port number field enter the SIM port to be used, either 47591 or 47592. In the Connect using field, select TCP/IP (Winsock) as shown.

Figure A57 - Connect to screenshot

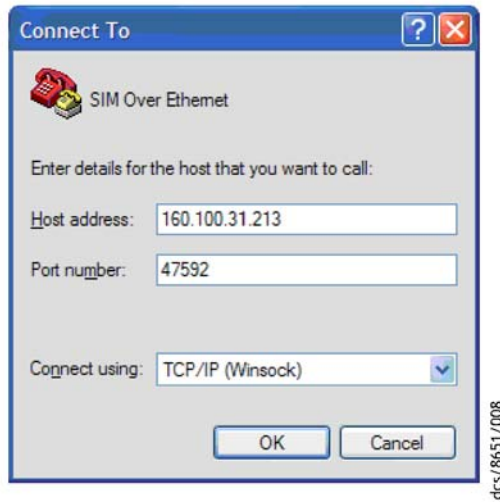

3. Set the ASCII settings to the following from the File/Properties/Settings menu

Figure A58 - ASCII setup screenshot

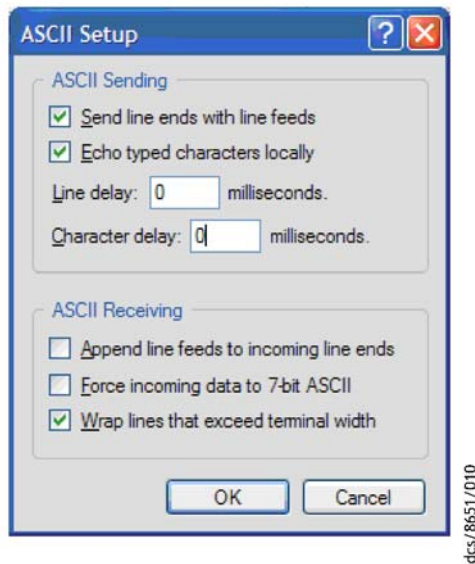

4. In the HyperTerminal window type the following: '?T' and press the ENTER key. If successful the user should get a reply with the following format:

157,28,19,42,0,72,121,35,0

In this example:

- 157 - indicates a pump controller
- 28 - indicates a GXS pump family
- 19 - indicates a GXS250
- 42 - indicates a GXB2600 booster
- 0 - indicates GXS screw pump
- 72 - indicates low volts, 7.5 kW DP and 7.5 kW BP
- 121 - indicates a harsh gas module
- 35 - indicates a normal thermal management type
- 0 - indicates a normal exhaust type

Refer to the SIM manual for more information about the various field elements and what they mean for GXS.

A2.12.2 Web server pages

The GXS pump has a built-in web server. To prevent interference with the pump control software the web server runs at a low priority so pages can be slow to load. All pages automatically refresh.

Before using the web server, first make the Ethernet connection to the pump, set the IP address and then check communications are working as detailed in [Appendix A2.12.1](#). Then open the web browser and type the IP address of the GXS into the web browser address bar. The web server has been tested on Internet Explorer and Firefox web browsers.

The following pages of information are available on the web server:

Overview

This page shows the overall status of the GXS pump and how many warnings and alarms are present.

Figure A59 - Overview screenshot

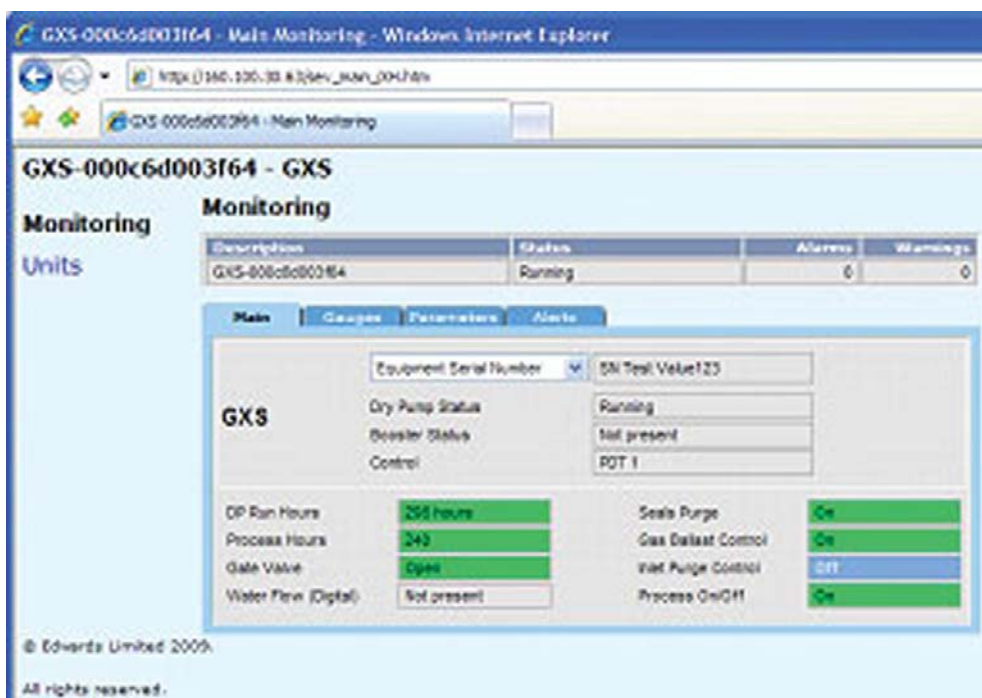

Gauges

This page shows detailed analogue gauge information in a graphical format.

Figure A60 - Gauges screenshot

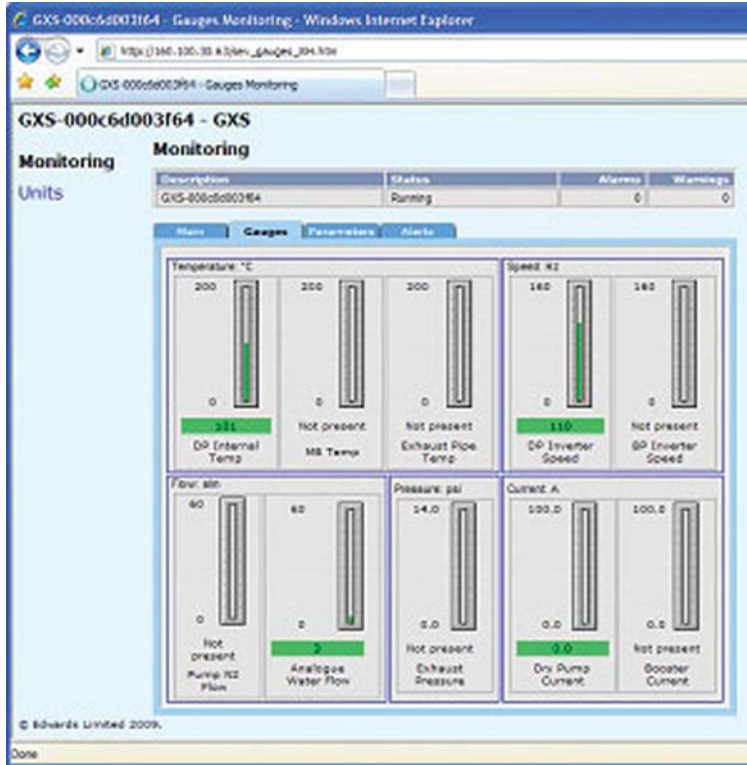

Parameters

This page shows detailed analogue sensor information and set point limits in a tabular textual format.

Figure A61 - Parameters screenshot

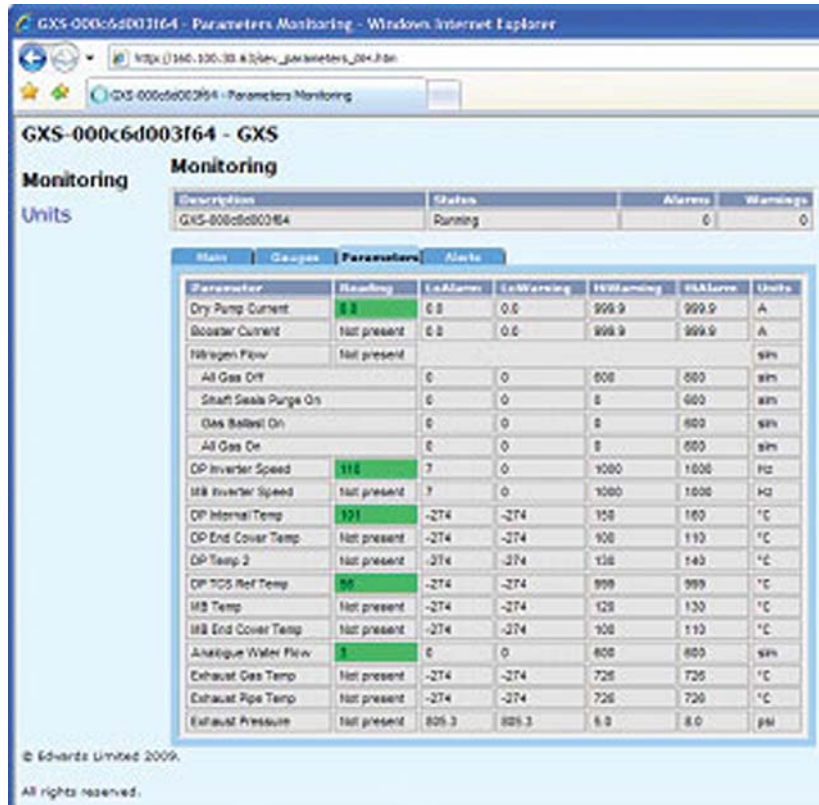

Alerts

This page shows active warnings and alarms.

Figure A62 - Alerts screenshot

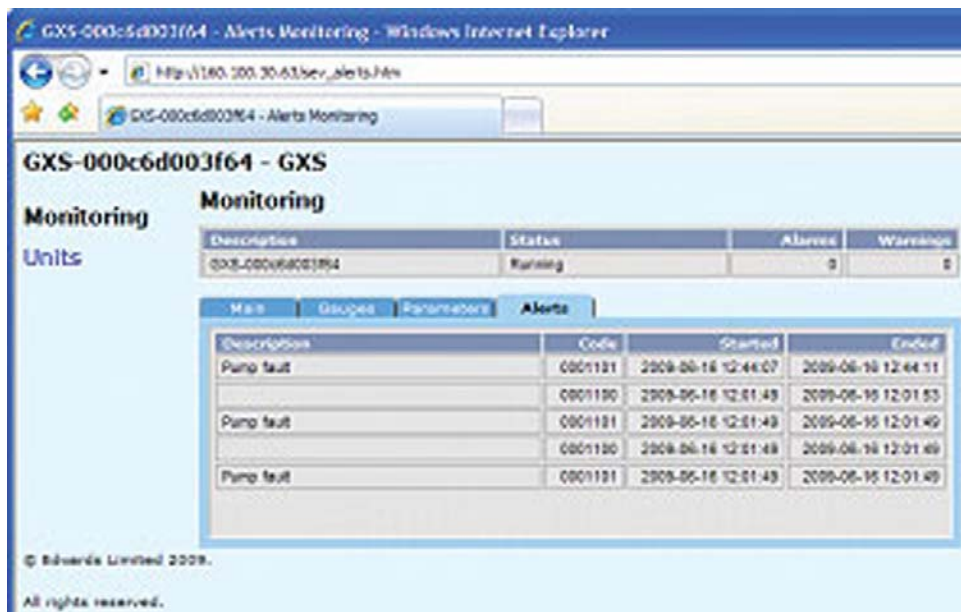

Units

This page can be used to configure the units displayed on the web pages.

Figure A63 - Units screenshot

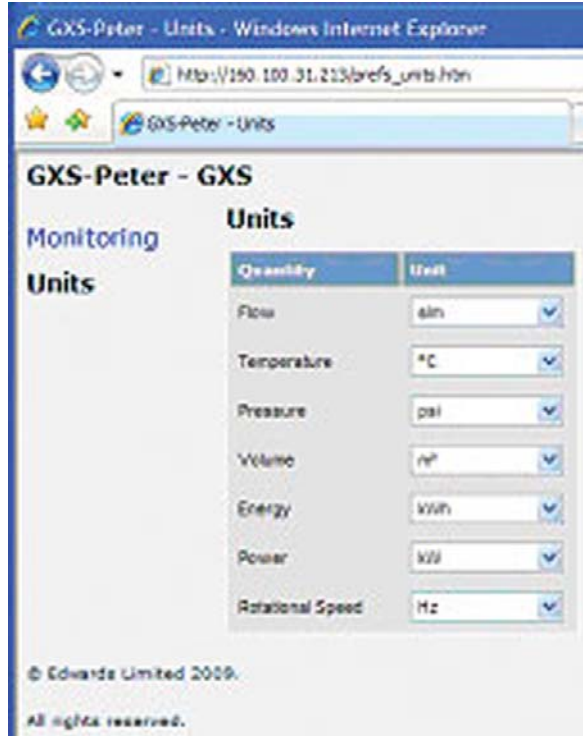

A2.13 How to use SIM protocol with a serial port

SIM protocol is used as a means of communication between Edwards vacuum pumps and other external control and monitoring equipment. For more information about SIM protocol, refer to the SIM protocol manual P411-00-200.

To use SIM protocol by a serial port, connect the GXS to the computer as described in Section 3.15. Start the program HyperTerminal on the computer and select the COM port to be used. Then configure the COM port to the following settings:

Table A27 - COM port settings

COM port	Requirements
Bits per second	9600
Data bits	8
Parity	None
Stop bits	1
Flow control	None

Next set the ASCII settings as follows:

Figure A64 - ASCII settings screenshot

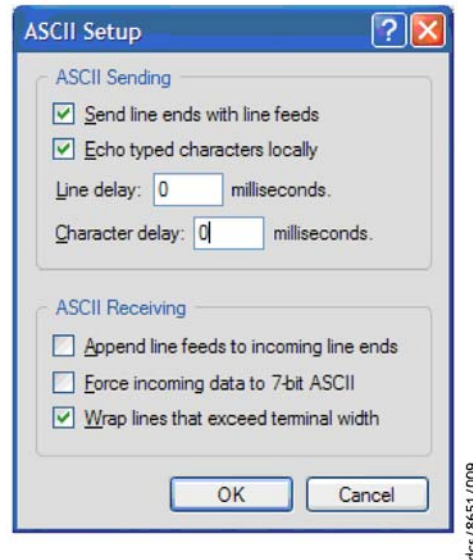

In the HyperTerminal window type the following: '?T' and press the ENTER key.

If successful you should get a reply with the following format:

157,28,19,42,0,72,121,35,0

In this example,

- 157 - indicates a pump controller
- 28 - indicates a GXS pump family
- 19 - indicates a GXS250
- 42 - indicates a GXB2600 booster
- 0 - indicates GXS screw pump
- 72 - indicates low volts, 7.5 kW DP and 7.5 kW BP
- 121 - indicates a harsh gas module
- 35 - indicates a normal thermal management type
- 0 - indicates a normal exhaust type

Refer to the SIM manual for more information about the various field elements and what they mean for GXS. Any other query and command can be sent by typing the operation and parameter followed by the ENTER key.

A2.14 How to set up the MCM MicroTIM using the PDT

If the MCM MicroTIM is fitted to the GXS system, all the pump configuration settings that are made using the PDT are automatically stored in the MicroTIM. This means that if a new GXS system is fitted, for example whilst servicing the existing system, there is no need to configure the new pump settings if the original MicroTIM is used.

The PDT can also be used to configure the channel 2 input and channel 4 output on the MCM MicroTIM itself. Refer to the MicroTIM instruction manual D373-60-880 for full information about MicroTIM installation and set up.

The following menus are used by the PDT to configure the MCM MicroTIM channel 2 input and channel 4 output.

Figure A65 - MicroTIM options menu

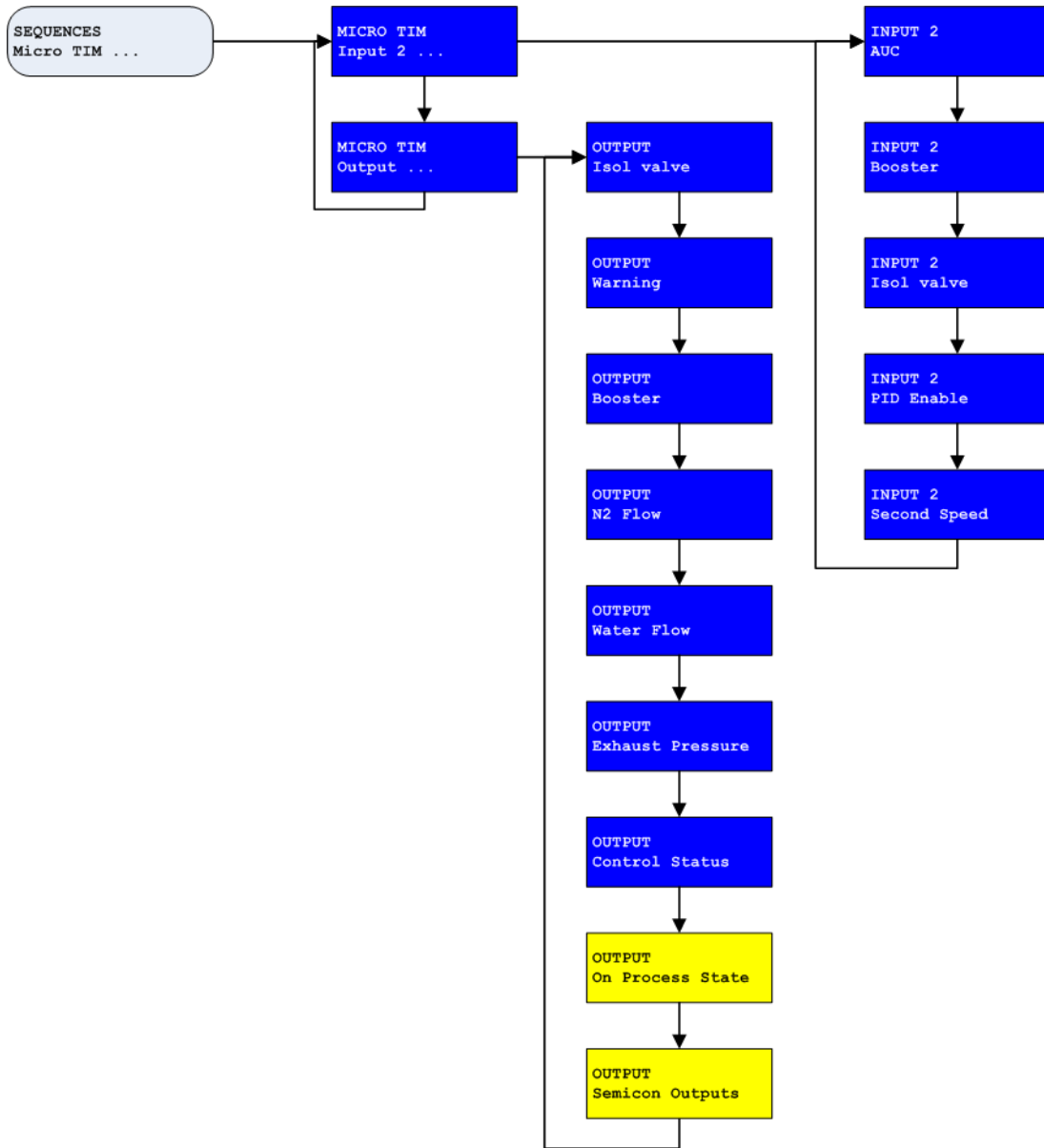

A2.14.1 Configuring the channel 2 input

By default, the MCM MicroTIM channel 2 input is configured to control Green Mode/Standby mode for GXS but the user has the option of setting input 2 to turn the booster on/off, operate the inlet isolation valve, enable PID or enable the second speed.

From the **MicroTIM** menu, select **Input 2...** and then scroll down the menu and press **ENTER** to select the input of choice.

Notes: 1. Only one input option can be active at a time.

2. If using Channel 2 to control the booster, the booster will not start unless the dry pump is on. This input is ignored if the GXS system does not have a booster.

3. The Second Speed input can be used to control the speed of either the dry pump or the booster, this can be set using the **SPEED CONTROL** menus, refer to [Appendix A2.10](#).

A2.14.2 Configuring the channel 4 output

By default, the MCM MicroTIM channel 4 output is configured to show the status of the isolation valve (if fitted). The user has the option of configuring channel 4 to monitor the status of system warnings, booster, nitrogen flow, water flow, exhaust pressure and remote/local control.

From the **MicroTIM** menu, select **Output 4...** and then scroll down the menu and press **ENTER** to select the output of choice.

- Notes:**
1. Only one output option can be active at a time.
 2. Booster status is only available for GXS combination systems that contain a dry pump and booster.
 3. Isolation valve, nitrogen flow and water flow monitoring kits are available as optional accessories and status can only be monitored if fitted.

A2.15 How to run the booster independently from the dry pump

The booster can be set up to run independently from the dry pump using the PDT. The booster can then be controlled using the PDT, the MCM MicroTIM, the SIM protocol or Profibus.

If controlling the booster from the PDT or by using SIM protocol or Profibus then the booster start mode needs to be changed to 'manual' using the PDT. Refer to [A2.7.1](#) for instructions on setting the booster to manual mode. Once in manual mode, the booster will operate independently from the dry pump.

A2.15.1 Run the booster manually using the PDT

To turn the booster on using the PDT follow this procedure and refer to [Figure A66](#):

1. From the **SETUP** menu, select **Command Menu...** (requires an access code: 202.)
2. Scroll down and select **MB...**
3. Scroll down and select **On**

Figure A66 - Booster commands menu

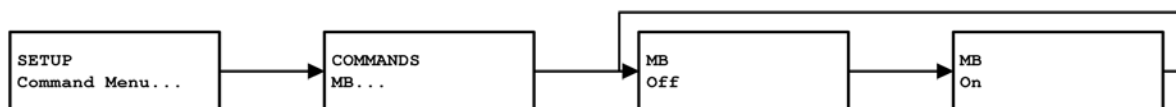

gea-figA42

A2.15.2 Run the booster using SIM and Profibus

Refer to the SIM and Profibus manuals for information on how to control the booster using these protocols.

A2.15.3 Run the booster using the MCM MicroTIM

If controlling the booster independently using the MCM MicroTIM then Input 2 needs to be configured to Booster. Refer to [A2.14](#) for instructions on how to configure the MCM MicroTIM using the PDT. Once Input 2 has been configured to Booster, Input 2 will start and stop the booster independently of the dry pump.

This page has been intentionally left blank.

Appendix A3 Troubleshooting

A3.1 PDT events

There are some circumstances in which the GXS system is unable to respond to a command that has been made. To help in understanding why an operation was not possible the pump triggers an event and displays a message on the PDT (if fitted).

A3.1.1 LED event indicators

When a new event is triggered, the warning LED on the PDT will flash. To acknowledge an event, press **ENTER** on the PDT. Once the event has been acknowledged the warning LED on the PDT will return to its previous state.

Note that events are only indicated by the PDT warning LED, the pump LEDs do not indicate events.

A3.1.2 PDT event messages

When a new event is triggered an event message appears on the PDT. Refer to [Table A28](#) for a list of event messages that might be displayed on the PDT with possible causes and actions that should be taken.

Once an event has been acknowledged, the event message clears from the PDT.

Table A28 - Events

Event message on PDT	Possible cause	Action
EVENT 11.41 Can not go on-process. Pump has active warning.	Pump has an active warning.	Either clear the source of the warning or enable pump to go on-process with a warning (refer to Appendix A2.6.7).
EVENT 11.42 Warming pump up before going on-process.	Pump is not warm enough to go on-process immediately.	Either reduce the warm up temperature (refer to Appendix A2.6.1), enable pump on-process when cold (refer to Appendix A2.6.2) or wait for the pump to go on-process when it has warmed up.
EVENT 11.45 Can not go on-process. Pump has active interlock.	Pump is running a DP Clean sequence which has not completed.	Either wait for DP clean to complete or manually turn it off (refer to Section 4.9). If using solvent flush Edwards recommends that the pump is allowed to complete the purge cycle. If DP clean has been configured to run a purge cycle after the clean cycle then it needs to be sent two 'off' commands (refer to Section 4.9.2).
EVENT 317.43 Can not start Command. Pump is not in Green Mode mode.	The pump must be in Green Mode/Standby mode to initiate PID auto tune.	Set the pump into Green Mode/Standby mode and then start PID auto tune.
EVENT 317.46 Can not start Command. Pump is not running.	The pump must be running to initiate a PID auto tune.	Start the pump, set it into Green Mode/Standby mode and then start PID auto tune.
EVENT 317.47 Can not start Command. Already Running on pump.	The pump is already running a PID auto tune.	Either let the auto tune complete or stop it before sending the PID auto tune command again.
EVENT 322.22 Can not start Command. Pump is not stopped.	The pump must be stopped before starting solvent soak.	Stop the pump and then repeat command.

Table A28 - Events (continued)

Event message on PDT	Possible cause	Action
EVENT 331.42 Can not start Command. Pump is not warmed up.	The pump must be warmed up and in Green Mode/Standby mode to initiate a DP Clean sequence.	Either reduce the warm up temperature (refer to Appendix A2.6.1), enable pump on-process when cold (refer to Appendix A2.6.2) or wait for the pump to warm up. Make sure pump is in Green Mode/Standby mode before attempting a DP Clean.
EVENT 331.43 Can not start Command. Pump is not in Green Mode mode.	The pump must be in Green Mode/Standby mode to initiate a DP Clean sequence.	Set the pump into Green Mode/Standby mode and then start DP clean.
EVENT 331.46 Can not start Command. Pump is not running.	The pump must be running to initiate a DP Clean sequence.	

A3.2 Warnings

The pump controller generates a warning when a problem is encountered.

By default, the GXS pump is prevented from going on-process when there are active warnings so it is important to investigate the cause of a warning. It is possible to configure the pump so that it will go on-process with active warnings - refer to A2.6.7 for more information.

Once the problem that caused a warning has been resolved, the warning is cleared by the pump controller.

A3.2.1 LED warning indicators

If the pump encounters a problem, warnings are indicated on the LEDs on the front control panel, the rear panel and on the PDT if fitted.

The warning LEDs on the front control panel and rear panel illuminate continuously when a warning is generated.

If a PDT is fitted, the warning LED flashes to indicate a new warning. Refer to [Appendix A2.3](#) for more information on how warnings are indicated and how they can be acknowledged using the PDT.

Once all the warnings are cleared, the warning LEDs extinguish.

A3.2.2 PDT warnings

If a PDT is fitted, each warning triggers a warning message to be displayed. Refer to [Appendix A2.3](#) for more information on how warnings are handled by the PDT.

[Table A29](#) lists the warning messages that might be displayed on the PDT with possible causes and actions that should be taken.

Table A29 - Warnings

Warning message on PDT	'Action' message on PDT	Possible cause	Action
Warning 1.01 Power interrupt	Check pwr supply	There has been a brownout of the electrical supply to the pump lasting more than 1 second.	Check the electrical supply.

Table A29 - Warnings (continued)

Warning message on PDT	'Action' message on PDT	Possible cause	Action
Warning 39.11 Exh Press High	Exhaust Blocked Service Pump	The pressure in the exhaust pipeline is too high. - A valve in the pipeline may be shut. - There may be process debris or condensation in the exhaust pipeline. - You may have too many pumping systems connected to the exhaust pipeline.	Refer to Section 4.6 to determine the exhaust pressure that triggered the warning. Check that all valves in the exhaust line are open and consider whether process debris or condensation are likely.
Warning 39.13 Sensor missing	-	The exhaust pressure transducer is not fitted, or is disconnected or has failed.	Check and rectify as necessary.
Warning 51.13 Sup Missing	See manual	There is a communication problem within the pump controller. Refer to Appendix A3.5.1 .	Cycle the power to the pump. If the warning persists, contact Edwards to replace the pump controller.
Warning 54.11 MB Temp High	See manual	The temperature of the booster pump is too high.	- Check that cooling water is connected, switched on and is to specification given in Section 2.6 .
Warning 54.13 Sensor missing	-	The booster temperature sensor may have become disconnected or failed.	- Check that the booster pump temperature sensor is fitted and is correctly connected. - Check the operation of the sensor and replace it if it has failed.
Warning 55.11 DP Temp High Or Warning 63.11 DP Temp High	See manual	The temperature of the pump is too high.	Check that cooling water is connected, switched on and is to specification given in Section 2.6 .
Warning 55.13 Sensor missing Or Warning 63.13 Sensor missing	-	The dry pump temperature sensor may have become disconnected or failed.	- Check that the dry pump temperature sensor is fitted and is correctly connected. - Check the operation of the sensor and replace it if it has failed.
Warning 71.13 AC Sup Missing	See manual	The pump controller cannot communicate with the accessory module.	- Check that the accessory module is correctly connected to the pump and then cycle the power to the pump. - If this warning persists, contact Edwards.
Warning 152.01 Valve Not Shut	Check ISOL Valve	The inlet isolation valve has failed to close.	Check the wiring and air supply to the inlet isolation valve. NOTE: this warning will only clear when the valve has successfully been opened and closed.

Table A29 - Warnings (continued)

Warning message on PDT	'Action' message on PDT	Possible cause	Action
Warning 153.01 Valve Not Open	Check ISOL Valve	The inlet isolation valve has failed to open.	Check the wiring and air supply to the inlet isolation valve. NOTE: this warning will only clear when the valve has successfully been closed and opened.
Warning 176.01 MB INV xxxx yyyy	xxxx yyyy aaaaaaaaaaaaaaaa	Booster Inverter has raised a warning code.	Refer to Appendix A3.4 for more information.
Warning 176.13 No MB Inv Comms	See manual	The pump controller cannot communicate with the booster inverter.	Check the wiring between the pump controller and the booster inverter.
Warning 186.01 DP INV xxxx yyyy	xxxx yyyy aaaaaaaaaaaaaaaa	Dry pump Inverter has raised a warning code.	Refer to Appendix A3.4 for more information.
Warning 186.13 No DP Inv Comms	See manual	The pump controller cannot communicate with the dry pump inverter.	Check the wiring between the pump controller and the dry pump inverter.
Warning 196.01 DP Inv xxxx yyyy	Diag aaaa bbbb /zzzzzzzzzzzzzzzz	DP 2nd Dry Pump Inverter has raised an alarm and stopped the dry pumping system.	Refer to Appendix A3.4 for more information.
Warning 196.13 No DP Inv Comms	See manual	The pump controller cannot communicate with the dry pump 2nd inverter.	Check the wiring between the pump controller and the dry pump inverter.
Warning 314.11 DP Speed too low	Stop Pump Contact Service	The pump is running more slowly than the speed that is demanded.	Stop the pump immediately and contact Edwards. Do not run the pump until it has been checked.

A3.3 Alarms

The pump controller generates an alarm when a serious problem is encountered.

Depending on the reason for the alarm, the whole system or just the booster (if fitted) will shut down - refer to [Section 4.5](#) and [4.6](#) for more information about alarms.

If the system has shut down due to an alarm, the problem must be rectified before attempting to re-start the pump.

Once the problem that caused the alarm has been resolved, the alarm is cleared by the pump controller.

A3.3.1 LED alarm indicators

Alarms are indicated on the LEDs on the front control panel, the rear panel and on the PDT if fitted.

The alarm LEDs on the front control panel and rear panel illuminate continuously when an alarm is generated.

If a PDT is fitted, the alarm LED flashes to indicate a new alarm. Refer to [Appendix A2.3](#) for more information on how alarms are indicated and how they can be acknowledged using the PDT.

Once all the alarms are cleared, the alarm LEDs extinguish.

A3.3.2 PDT alarms

If a PDT is fitted, each alarm triggers an alarm message to be displayed. Refer to [Appendix A2.3](#) for more information on how alarms are handled by the PDT.

[Table A30](#) lists the alarm messages that might be displayed on the PDT with possible causes and actions that should be taken.

Table A30 - Alarms

Alarm message on PDT	'Action' message on PDT	Possible cause	Action
Alarm 1.01 Stop Activated	-	<ul style="list-style-type: none"> - The emergency stop has been activated. - There is a fault with the EMS circuit or the EMS link plug has not been fitted or has come disconnected. - There has been a brownout of the electrical supply to the pump lasting more than 1 second. 	<p>If the EMS button has been used on the pump, refer to Section 4.8 to re-set it. Otherwise check and reset the EMS circuit and re-start the pump.</p> <p>NOTE: the alarm message will remain on the display until you restart the pumping system.</p>
Alarm message on PDT	'Action' message on PDT	Possible cause	Action
Alarm 1.01 Sys Config Fault	-	The pump system type has not been set properly.	Contact Edwards for a service engineer to configure the pump system type correctly or replace the pump controller electronics.
Alarm 39.12 Exh Press High	Exhaust Blocked Service Pump	The Exhaust pressure has reached maximum allowed.	Refer to Section 4.6 to determine the exhaust pressure that triggered the alarm. See Warning 39.11 for causes and actions.
Alarm 54.12 MB Temp High	See manual	The booster temperature has reached the maximum allowed so the booster has stopped.	Refer to Section 4.6 to determine the temperature that triggered the alarm. See warning 54.11 for causes and actions.
Alarm 55.12 DP Temp High Or Alarm 63.12 DP Temp High	See manual	The dry pump temperature has reached the maximum allowed so the system has stopped.	Refer to Section 4.6 to determine the temperature that triggered the alarm. See warning 55.11 for causes and actions.
Alarm 174.10 Booster Stopped	See manual	Booster speed too low - rotor is probably locked.	Contact Edwards
Alarm 176.01 MB INV xxxx yyyy	xxxx yyyy aaaaaaaaaaaaaaaa	Booster Inverter has raised an alarm and stopped the system.	Refer to Appendix A3.4 for more information.
Alarm 176.01 MB Not Running	See manual	Booster Inverter will not start up when requested.	Check inverter fault history.
Alarm 176.13 No MB Inv Comms	See manual	The pump controller cannot communicate with the booster inverter during start-up checks.	Check the wiring between the pump controller and the booster inverter.

Table A30 - Alarms (continued)

Alarm 184.10 Dry Pump Stopped	See manual	The dry pump speed is very low. The rotor might be locked.	Cycle the power to the pump and attempt to re-start. If this fails, contact Edwards.
Alarm 186.01 DP INV xxxx yyyy	xxxx yyyy aaaaaaaaaaaaaaaa	Dry pump Inverter has raised an alarm and stopped the system.	Refer to Appendix A3.4 for more information.
Alarm 186.01 DP Not Running	See manual	Dry pump Inverter will not start up when requested.	Check inverter fault history.
Alarm 186.13 No DP Inv Comms	See manual	The pump controller cannot communicate with the dry pump inverter during start-up checks.	Check the wiring between the pump controller and the dry pump inverter.
Alarm 196.01 DP Inv xxxx yyyy	Diag aaaa bbbb /zzzzzzzzzzzzzzzz	DP 2nd Dry Pump Inverter has raised an alarm and stopped the dry pumping system.	Refer to Appendix A3.4 for more information.
Alarm 196.13 No DP Inv Comms	See manual	The pump controller cannot communicate with the dry pump 2nd inverter.	Check the wiring between the pump controller and the dry pump inverter.
Alarm 314.12 DP Speed too low	Do not restart Contact Service	The pump is running more slowly than the speed that is demanded.	Contact Edwards. Do not attempt to start the pump until it has been checked - this alarm is latched and the pump will not restart.

A3.4 Inverter warnings and alarms

The inverters used to drive the dry pump and booster can also generate warnings and alarms if problems are encountered. Inverter warning and alarm codes are displayed by the PDT if fitted.

The alarm and warning codes are each reported as a 16-bit word encoded as 4 hexadecimal numbers. The codes are displayed as follows:

1234 5678

Where:

The first 4 digits signify an alarm code and,

The second 4 digits signify a warning code

Digits 1 - 8 are reported as hexadecimal digits from 0 to F.

To determine the cause of a warning or alarm you must first decode each hexadecimal number. 0 indicates that there is no alert for that bit. Normally you will only see codes of 1, 2, 4 or 8 for each bit but if two or more events occur in the same bit then these will be added together.

For example:

5 = 1 + 4 so if code 5 is displayed it means that alerts 1 AND 4 are active

B = 1 + 2 + 8 so if code B is displayed it means that alerts 1, 2 AND 8 are active.

To decode inverter warning and alarm codes, refer to [Table A31](#) to convert the hexadecimal digits into alert combinations and then refer to [Table A32](#) and [A33](#)).

Table A31 - Hexadecimal to digital conversion

BIT SET COMBINATIONS		
HEXADECIMAL	DECIMAL	Combination
F	15	8+4+2+1
E	14	8+4+2
D	13	8+4+1
C	12	8+4
B	11	8+2+1
A	10	8+2
9	9	8+1
8	8	8
7	7	4+2+1
6	6	4+2
5	5	4+1
4	4	4
3	3	2 + 1
2	2	2
1	1	1

Table A32 - Inverter alarm codes

Inverter alarms			
BIT SET	Fault code combination	PDT reported fault name	Description
1	8	ACCELERATION_TO	If motor has not accelerated to a minimum speed of 10 Hz within 60 secs then drive will try to restart 3 times before giving alarm
	4	OVERLOAD_TO	Alarm given when dry pump speed is below 7 Hz for 3 minutes or 30 minutes for a booster
	2	SC_MODE_INTERLOCK	Internal fault contact Edwards
	1	FLASH_DOWNLOAD_FAULT	Internal fault contact Edwards
2	8	POST_FAULT	Internal fault contact Edwards
	4	OSTEST_FAULT	Internal fault contact Edwards
	2	EEPROM_FAULT	Internal fault contact Edwards
	1	PWM_TRIP	Inverter output switched off, active when drive not running. Restart pump or cycle power to reset.

Table A32 - Inverter alarm codes (continued)

Inverter alarms			
BIT SET	Fault code combination	PDT reported fault name	Description
3	8	MISSING_PHASE_TIMEOUT	Indicates a missing input phase - check power connections to pump and fuses in supply. Warning should appear first and then dry pump trips after 10 minutes and booster trips after 30 minutes.
	4	EMS	EMS has been activated. Check EMS button at front and EMS plug in the back of pump controller.
	2	DESAT_FAULT	Internal fault contact Edwards
	1	UNDERT	Inverter is too cold. See warning register to determine source of problem.
4	8	OVERT	Motor/Drive system overtemperature - refer to warning code to determine source. Check cooling.
	4	OVERI	Motor overcurrent
	2	OVERV	Inverter overvoltage
	1	Reserved	Reserved

Table A33 - Inverter warning codes

Inverter warnings			
BIT	Fault code combination	Name	Description
5	8	Reserved	Reserved
	4	Reserved	Reserved
	2	LOWTW	Condensation warning, indicates that the inverter (water) temperature is lower than expected - possible causes include inverter water valve stuck open.
	1	HIGHTW	Indicates that the inverter temperature is higher than expected - possible causes include no or low cooling water flow, inverter water valve stuck closed or water pipe to inverter blocked.
6	8	HIGHTC	Controller temperature above upper limit / Controller temperature sensor open circuit - check water supply
	4	HIGHTS	Inverter heat-sink temperature above upper limit / Inverter heat-sink temperature sensor open circuit - check water supply
	2	HIGHTM	Motor temperature above upper limit / Motor temperature sensor open circuit - check water supply
	1	MISSING_PHASE	The loss of one of the three input phases has been detected - check mains supply to drive or blown fuses
7	8	UTCREG	Upper controller temperature regulator active - current limit reduced - check cooling
	4	UTSREG	Upper heat sink temperature regulator active - current limit reduced - check cooling
	2	Reserved	Reserved
	1	LVREG	Lower voltage regulator active - check mains voltage
8	8	LOWVCC	Internal power supply fault - contact Edwards
	4	LOWTC	Low controller temperature - contact Edwards
	2	LOWTS	Low heatsink temperature - contact Edwards
	1	CAN LOSS	Reserved

Example:

PDT shows the following:
0108 0200

This translates to:

alarm 1 in bit 2 - PWM_TRIP

alarm 8 in bit 4 - OVERT

warning 2 in bit 6 - HIGHTM.

This means the motor overheated and switched the output off.

A3.5 Other problems

A3.5.1 Pump controller communications

The pump controller contains two processors that perform different functions. Under normal operation the two processors communicate with each other internally whilst they perform their functions.

Under fault conditions it is possible that the two processors stop communicating with each other. In this circumstance:

- The pump may continue to run normally, with gas valves and gate valves kept in the same state
- Depending which device is 'in control' of the system, control might be released (for example PDT).
- The front panel controls can be used to 'take control' and stop the pump but this will only be a simple stop, it will not be possible to use any of the shut down sequences such as Smart Stop.
- If the front panel controls or EMS button are used to stop the pump, the warning LEDs on the pump will flash and the alarm LED will illuminate. The inlet isolation valve will shut.
- Stop requests from all devices apart from the front panel controls will be ignored.
- Any requests to start the pump will be rejected.

For systems fitted with the MCM MicroTIM:

- If the pump is stopped when communication is lost then 'alarm present' is set on the alarm line.
- If the pump is running when communication is lost then the outputs to the MicroTIM are unaffected.