



ACP 120 / ACG 600

Industrial multistage Roots dry pump

Operating instructions



FOR SALES AND SERVICE PLEASE CALL:

PTB SALES T :: 626.334.0500
sales@ptbsales.com
service@ptbsales.com
www.ptbsales.com

DATE SERVICED: _____

Industrial multistage Roots dry pump ACP 120 / ACG 600

Dear Customer,
you have just purchased
an adixen dry pump.

We thank you and are
proud to include you in
our customers.

This product has benefited
from adixen Vacuum
Product's many years
of experience in dry
pumping.



This product is designed to generate vacuum by pumping on gases, but no liquids neither solids. It is dedicated for running in industrial environments.

⚠ DANGER

The pumps must not be operated in an area with risk of explosion. Consult the nearest support service to study a solution.

For optimum performance and to obtain full satisfaction from this equipment, we recommend that you study this manual before any intervention on your pump, in particular, the chapter on installation and start up.

APPLICATIONS:

Standard version for non corrosive applications: Loadlock pumping in industrial scope, freeze-drying, vacuum furnace, research and development, etc...

"G" version for the pumping of gas traces: corrodents, condensable vapors.

"Large Volume" version: for pumping volume $> 1 \text{ m}^3$.

BENEFITS:

Reduced volume and foot-print.
Low operating cost.
Excellent behavior in harsh environments.

FEATURES:

Multi-stage Roots technology
Water-cooled multi-voltage motor.

Industrial multistage Roots dry pump ACP 120 / ACG 600

This product complies with the requirements of European Directives, listed in the Declaration of Conformity contained in sheet **G 100** of this manual.

Copyright/Intellectual property:

The use of adixen products are subject to copyright and intellectual property rights in force in any jurisdiction.

All rights reserved, including copying this document in whole or any part without prior written authorization from adixen Vacuum Products.

Specifications and illustrations are subject to change without notice by adixen Vacuum Products.

Translated from original version

Operating instructions ACP 120 / ACG 600

Chapitre A

INTRODUCTION

- A 10** - Dry pump operational principle
- A 20** - ACP 120 / ACG 600 Range presentation
- A 40** - Technical characteristics
- A 50** - Accessories

Chapitre B

START-UP

- B 00** - Safety instructions
- B 10** - Handling/ Unpacking / Storage
- B 20** - Positioning the pump in the pumping installation
- B 25** - Filling the pump oil housings
- B 30** - Connection to the cooling circuit
- B 40** - Inert gas purge connection ("G" version)
- B 50** - Electrical connection
- B 51** - Checking the direction of rotation at initial pump start-up
- B 60** - Connection to the pumping circuit

Chapitre C

OPERATION

- C 00** - Safety recommendations for harsh processes
- C 10** - Use of the pump

Chapitre D

MAINTENANCE

- D 00** - Safety instruction related to maintenance
- D 10** - Maintenance frequency
- D 30** - Diagnosis and trouble shooting

Chapitre E

MAINTENANCE INSTRUCTIONS

- E 10** - Exchange standard repair
- E 11** - Preliminary precautions
- E 12** - Draining of the water cooling circuit
- E 14** - Disconnecting the pump from the installation
- E 15** - Conditioning the pump for shipping
- E 40** - Part cleaning and preparation
- E 50** - Pump draining
- E 300** - Replacing the LP bearings
- E 310** - Freeing up the ACP 120
- E 1030** - Helium test
- E 2020** - Exhaust pipe maintenance

Chapitre F

MAINTENANCE COMPONENTS

- F 00** - Spare parts - Instruction for use
- F 10** - Minor maintenance kit
- F 30** - Ingredients and consumables
- F 40** - Recommended standard tools
- F 125** - LP support components
- F 250** - Exhaust kit components

Chapter G

APPENDIX

- G 100** - Declaration of incorporation of partly completed machinery
- G 110** - Purposed electrical schematic
- G 200** - Service

Labelling

Operating instructions ACP 120 / ACG 600

CAUTION

Indicates a potentially hazardous situation which, if not avoided, could result in property damage.

CAUTION

Indicates a potentially hazardous situation which, if not avoided, could result in moderate or minor injury. It may also be used to alert against unsafe practices.

WARNING

Indicates a potentially hazardous situation which, if not avoided, could result in death or severe injury.

DANGER

Indicates an imminently hazardous situation that, if not avoided, will result in death or severe injury (extreme situations).

Before switching on the product, study the operating manual and make sure you follow the safety instructions it gives. You can recognise these by the 'Caution', 'Warning' and 'Danger' symbols. Good practice tips and manufacturer's recommendations are in a blue box.

The performance and operational safety of this product are guaranteed provided it is used normally in the operating conditions defined in this manual.







It is the customer's task to:

- train operators to use the product if they do not speak the language the manual is written in,
- ensure operators know the safe practices to apply when using the product,
- keep this operating instruction manual and all other documents complete and accessible to personnel at all times,
- make protective equipment available for the operator,
- assign responsibilities, specific duties according to the qualification level: only skilled and trained operator can work on the product for installation, first start up and maintenance authorized by the manufacturer,
- ensure that the following points are observed and monitored:
 - compliance with the applicable standards and directives of the country in which the product is being operated,
 - safety regulations governing the handling of hazardous substances,
 - safety accidents-prevention regulations,
 - product is used only as intended.

Labelling

Operating instructions ACP 120 / ACG 600

Symbols

Symbols / Marking	Description
	Caution: possible risk, read the operating instructions
	Warning: electrical shock hazard
	Presence of skilled technician is mandatory, duties intended to authorized and trained operator.
	Compulsory: wear gloves
	Compulsory: use a breathing mask
	Compulsory: wear protective glasses
	Earth connection
WATER IN	Cooling circuit connection
WATER OUT	Output water connection
N2	Inert gas purge connection

Manufacturer label (example)

adixen Vacuum Products		F - 74009 Annecy		CE	
N°	APXXXXXX	Type	ACP120	Ed.	12
THREE PHASES					
Volt	Full-Load current Ampere		Ampere rating of largest motor		
	50Hz	60Hz	50Hz	60Hz	
200 Δ	9	9	5.7	6.2	
230/240 Δ	8	8	5.5	5.6	
400/415	5	5	3.2	3.4	
460/480	5	5	9.1	8.1	
Electrical schematic diagram reference:					XXXXXXXX

Labelling

Operating instructions ACP 120 / ACG 600

Pump labels



WARNING
HOT SURFACE
Contact with pump bodies may cause burn.
Switch off and wait until pumps cooled
before servicing.

Located on the covers of the pump, this label warns the user against possible risk of injury due to any hand contact with hot surfaces. It states that protective gloves should be used before performing any intervention.



WARNING
MOVING PARTS PRESENT
Moving parts can crush and cut.
Keep hands or feet away from moving parts.

Located on the upper cover, this label informs the user, that moving parts present inside the pump could cause personal injury, like crushing or cutting. The user must keep all body parts away from moving parts.



WARNING
HEAVY OBJET
Can cause muscle strain or back injury.
Use lifting aids and proper lifting techniques
when removing or replacing.

Located on the upper cover, this label indicates that due to its heavy weight, the product should not be handled manually, but always through appropriate handling devices.



WARNING
HAZARDOUS VOLTAGE
Switch off the pump and
disconnect the main power cable
before opening the power box cover.

Located on the upper covers, this label indicates that some of the internal parts are energized and could cause electrical shocks in case of contact. It advises to disconnect the pump before any intervention or to properly lock-out and tag-out the equipment breaker before any intervention on the pump.



WARNING
Leakage current may be greater than 3.5 mA
Earth connection is essential before
connecting supply.

Label location



WARNING
HOT SURFACE
Contact with pump bodies may cause burn.
Switch off and wait until pumps cooled
before servicing.

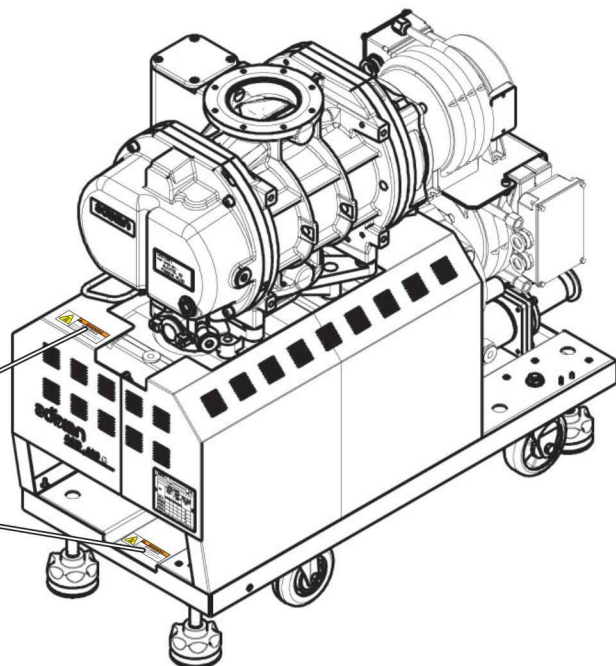



Introduction

Operating instructions – ACP 120 / ACG 600

A 010 *Dry pump operational principle*

A 020 *ACP 120 / ACG 600 Range presentation*

A 040 *Technical characteristics*

A 050 *Accessories*

Dry pump operational principle

Design to minimize potential residues

The equipment was designed to minimize potential residue deposits:

- by limiting the internal volumes that contain gas,
- by injecting N₂ purge on each pump stage to dilute the process gas ("G" version only).

Multi-stage Roots principle

The pump consists of 5 Roots type stages. The two rotors rotate without touching each other.

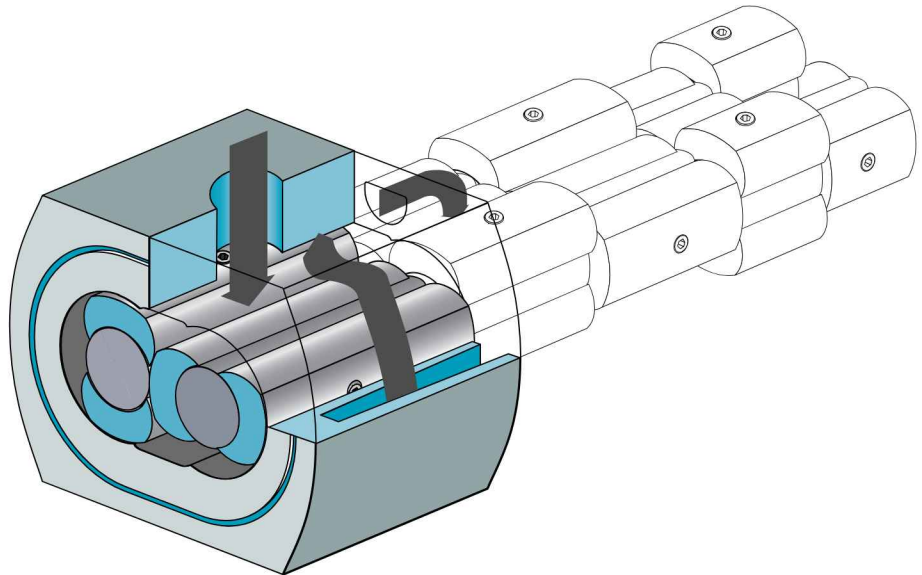

The three stages on the low pressure side are called "**LP stages**" and the two stages on the high pressure side are called "**HP stages**".

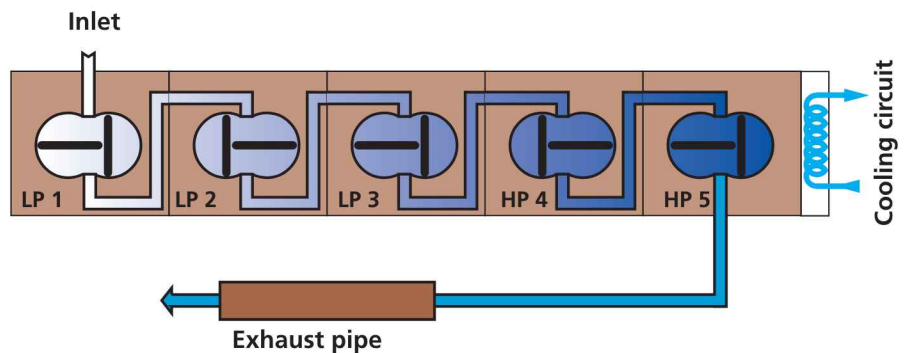

Dry pump operational principle

Tightness with environment

Tightness at low pressure side

The pump is fitted with ball bearings lubricated with fluorinated grease.

An overpressure zone is created around the bearing by injecting a neutral gas. The pressurization and the seals prevent pumped gases from migrating towards the bearings.

Neutral gas purging for the bearings is imperative for corrosive processes.

Tightness at high pressure side

The bearings are lubricated by oil splashing.

The oil sump is sealed from stage HP5 by a trap and a deflector.

Tightness at motor side (shaft passage)

The vacuum tightness is ensured by the motor design with built-in jacket (hermetically sealed).

This system provides total safety regarding leaks outside the pump and requires no maintenance.

Tightness at shutdown

The pump is fitted with an antisuckback valve in the exhaust tube, that prevents the exhaust being sucked back.

The pump in a pumping installation

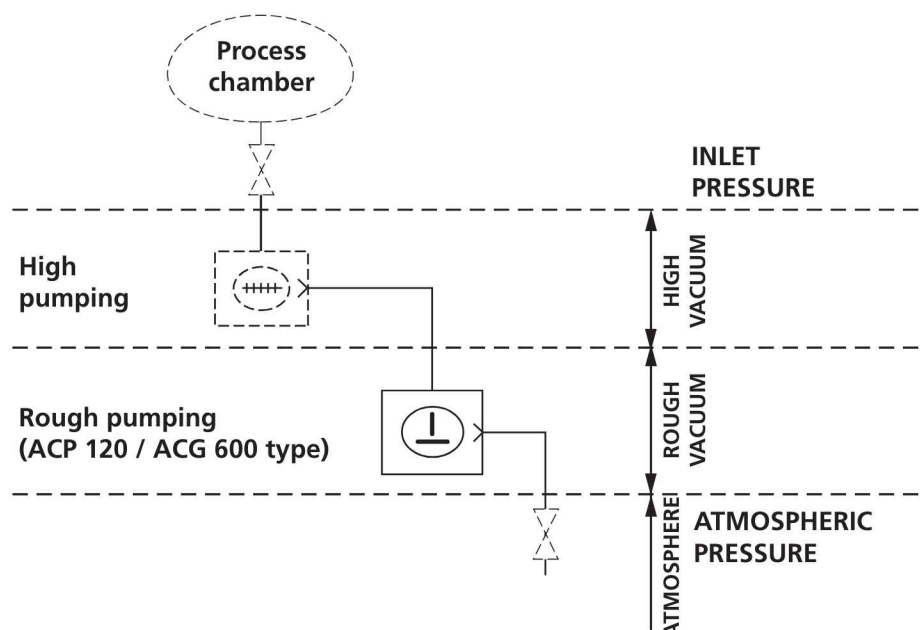

ACP 120 / ACG 600 range introduction

Range description



Type Multi-stage Roots primary dry pump:

- well known technology,
- reliability,
- cast iron pump body.

Dry pumping:

- guaranteed by design,
- residual gas spectrum free of traces of hydrocarbons.

Sealed water-cooled motor:

- safety: certified leaktight,
- multi-voltage.

Easy maintenance:

- due to interchangeable parts by field serviceable.

Two pump models according to various pumping capacities.

Two pump versions according to different applications.

Models description

This range includes:

- An ACP 120 dry pump available in two versions:
 - ACP 120: standard version dedicated to the non corrosive applications,
 - ACP 120 G: dedicated to the pumping of corrosive gas traces and condensable vapors.

Pump and facilities are integrated in a covered frame.

- A pumping group composed of an ACP 120 combined with a Roots, available also in standard version (ACG 600) and corrosive version (ACG 600 G).

"Large Volume" option

For each model, a 'Large volume' option is available. In this case a frequency converter is installed on the fonctionnal block to allow the pumping of volume larger than 1 m³ (maximum volume 10 m³).

ACP 120 / ACG 600 range introduction

Interfaces

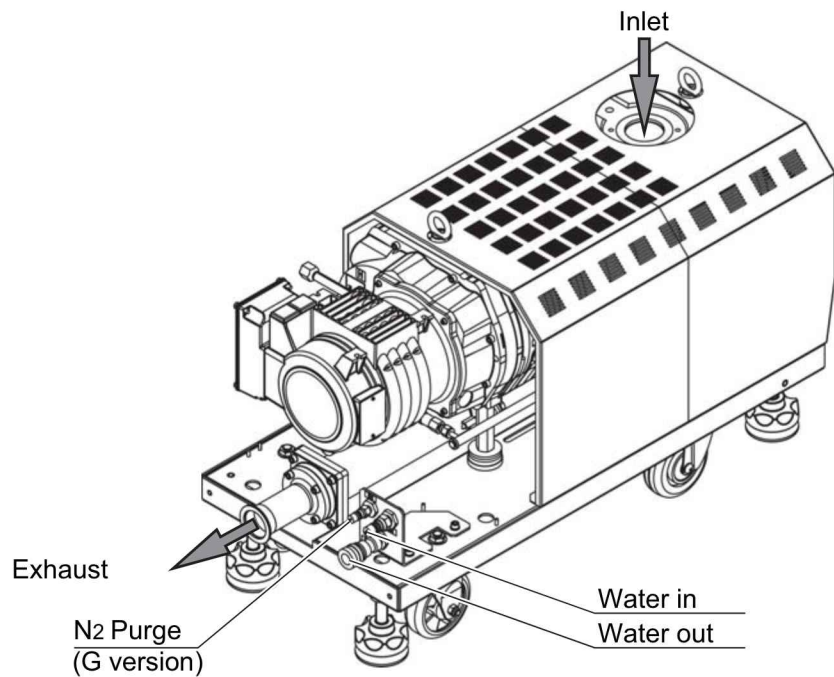

Internal equipment of the pumps

The pumps include a cooling circuit (water circuit).

The "G" version, especially designed for corrosive applications include an inert gas purge circuit.

Cooling circuit (ACP 120 principle schematic)

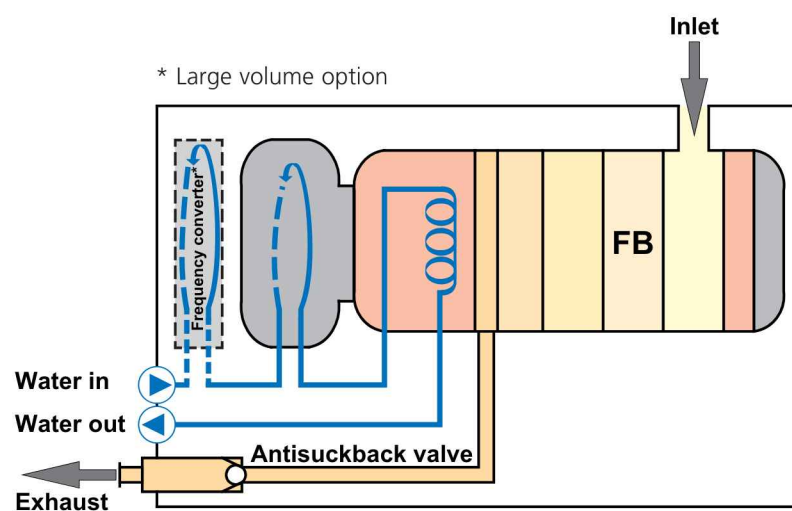

Nota: The customer can equipped the cooling circuit with a valve (see **B30**).

ACP 120 / ACG 600 range introduction

Cooling circuit
(ACG 600 principle schematic)

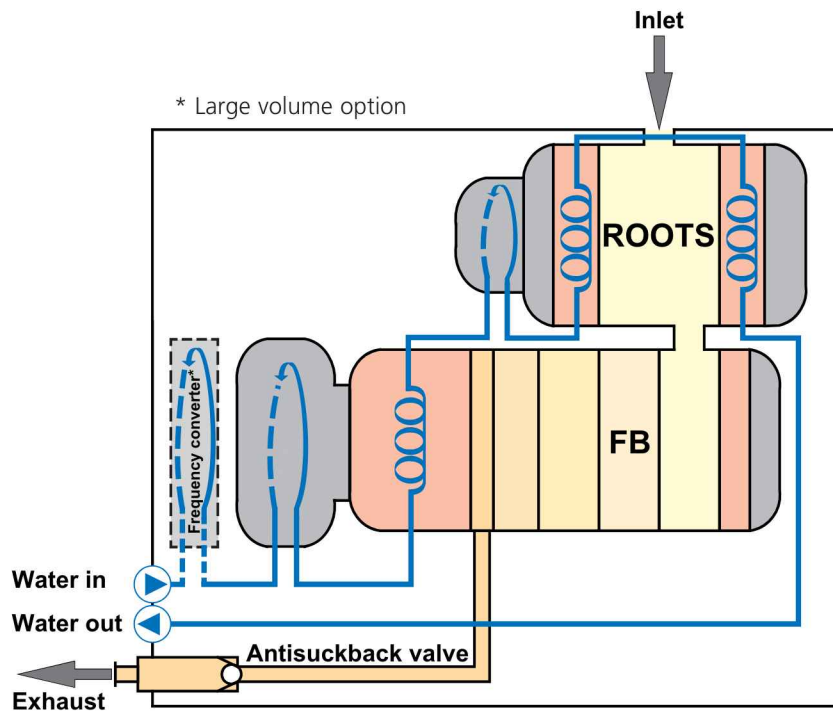

Nota: The customer can equipped the cooling circuit with a valve (see **B 30**).

N2 purge circuit
(principle schematic, "G" versions)

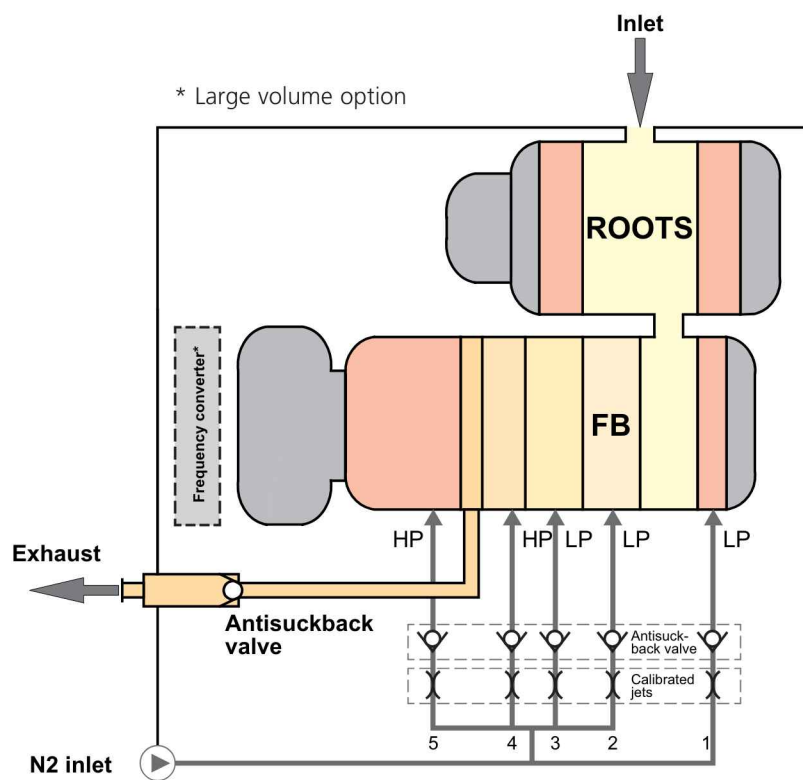

Technical characteristics

Characteristics	Units	ACP 120	ACP 120G	ACG 600	ACG 600G
Peak pumping speed (50/60 Hz)	m ³ /h	95/112		480/560	
	cfm	55.8/65.8		282/329	
	l/mn	1583/1867		8000/9333	
Typical ultimate pressure (without purge) (50/60 Hz)	hPa	$3 \cdot 10^{-2}/1.5 \cdot 10^{-2}$		$8 \cdot 10^{-3}/9 \cdot 10^{-4}$	
	mtorr	22.5/11.25		6/0.7	
Typical ultimate pressure (with 35 slm purge) (50/60 Hz)	hPa	–	$9 \cdot 10^{-2}/5 \cdot 10^{-2}$	–	$9 \cdot 10^{-3}/6 \cdot 10^{-3}$
	torr	–	67.5/37.5	–	6.7/4.5
Maximum volume	m ³	Standard version: 1 ⁽³⁾			
		"Large Volume" version: 10			
Maximum frequent pumping cycles on 1 m ³ volume	mn	20 ⁽⁴⁾			
Maximum continuous inlet flow	slm	80		60	
Supply voltage ⁽¹⁾	V	200/230 V - 380/480 V - 3 phases - 50/60 Hz			
Power consumption at ultimate pressure (50/60 Hz)	kW	1.3/1.5		1.8/2	
Power consumption at max. inlet flow	kW	1.8		3.6	
Power consumption at full load	kW	6		8	
Maximum exhaust overpressure	hPa	1200			
	torr	900			
Minimum cooling water flow	l/mn	5			
	gal/mn	1.32			
Purge flow	slm	–	0 to 60	–	0 to 60
Fluid capacity	l	ACP: 0.35		ACP: 0.35 Roots: 0.7	
Inlet flange		DN 50 ISO-KF		DN 100 ISO-K	
Exhaust flange		DN 40 ISO-KF			
Dimension (l x w x h)		See drawings on next pages			
Weight	kg	205		320	
Maximum sound level ⁽²⁾	dB(A)	< 65		< 68	

(1) According to CE regulations, A3H Series can withstand a supply voltage variation of $\pm 10\%$.

(2) Measured at 1 m length and 1.6 m height according to ISO 9614-2 standard.

(3) This pump is certified for pumping a volume of 1 m³. In case of larger volume, use a "Large Volume" version.

(4) For pumping cycles on higher volume, contact us.

Technical characteristics

Environmental conditions:	
Use of the product	indoor use
Altitude	up to 2000 m
Ambient operating temperature	5 to 40 °C (41 to 104 °F)
Storage temperature	-10 to 60 °C (14 to 140 °F)
Maximum relative humidity	80 % for temp. up to 31 °C (87 °F) decreasing linearly to 50 % at 40 °C (104 °F)
Transient overvoltage	category II
Pollution degree	rate 2
Ingress Protection	IP 55

Technical characteristics

Dimensions (mm/inches)

ACP 120 model

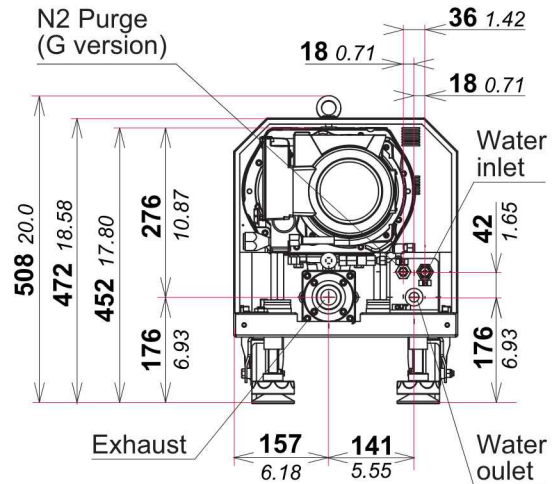
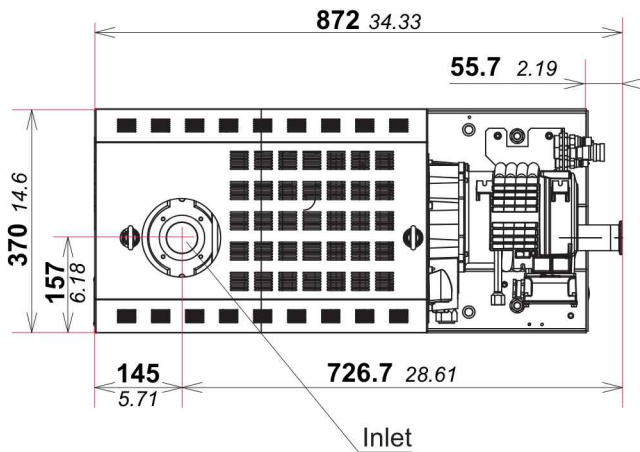

ACP 120 "Large Volume" model

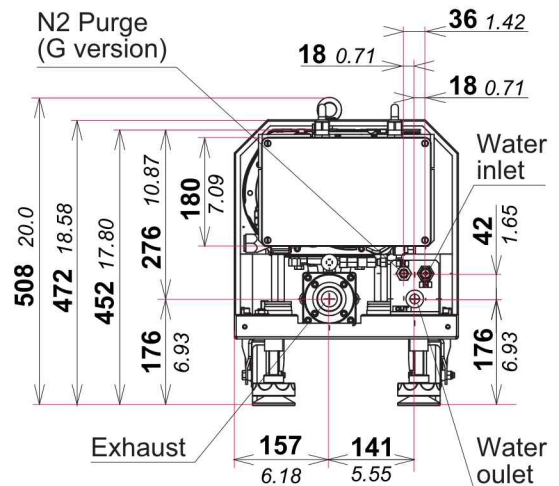
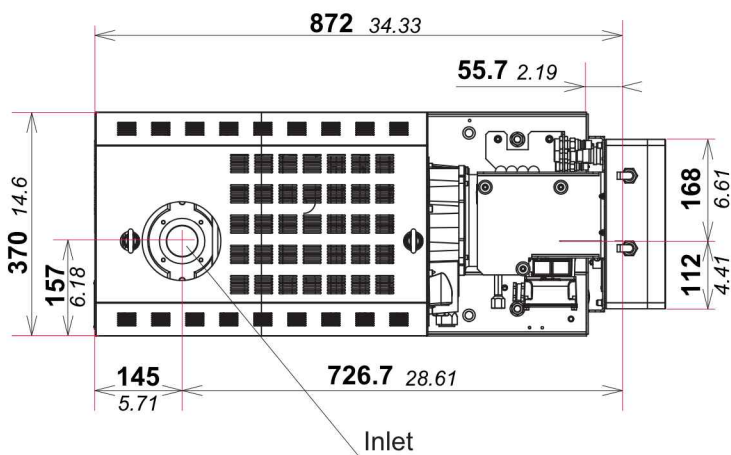

Technical characteristics

Dimensions (mm/inches)

ACG 600 model

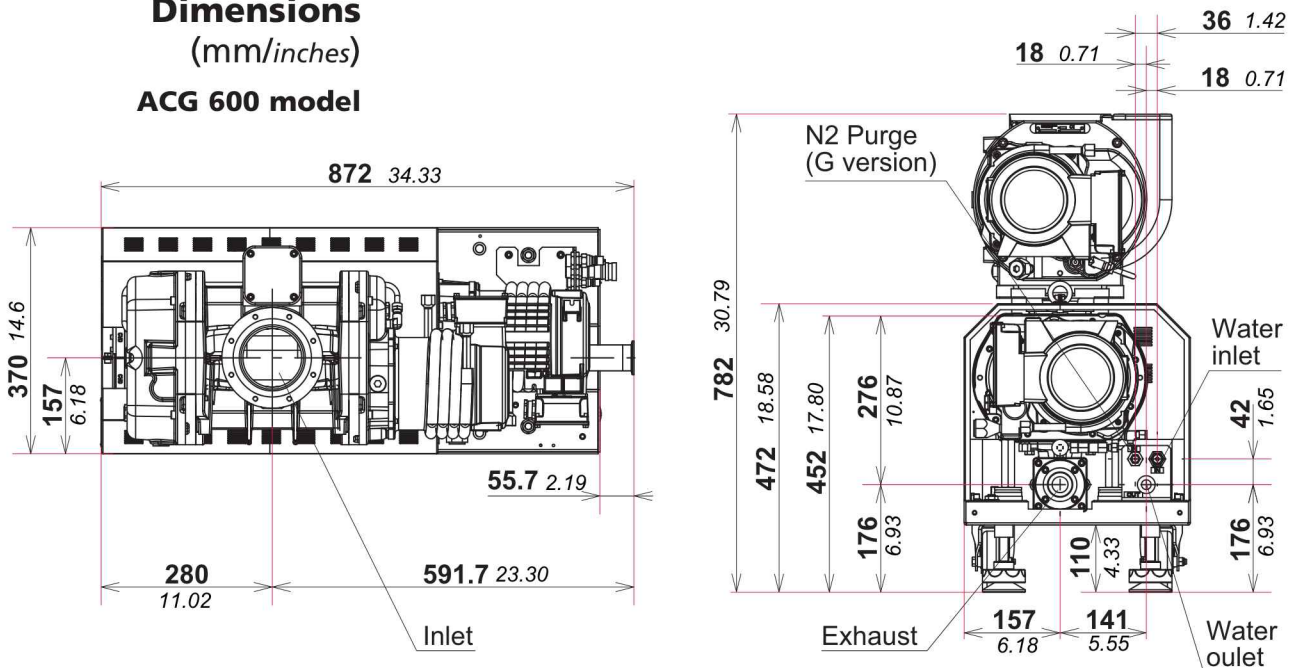

ACG 600 "Large Volume" model

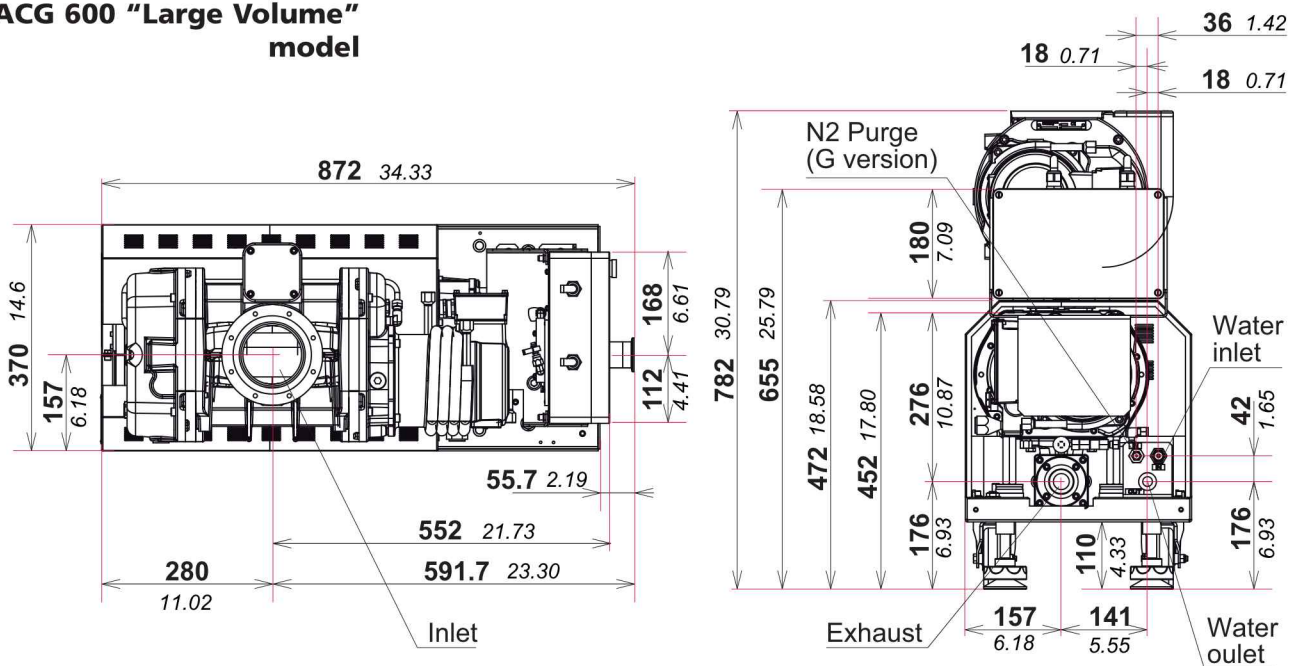

Accessories

Isolation valve at pump inlet

This valve avoids a reverse flow of gas to the chamber and increases tightness when the pump is switched off.

It also isolates the running pump from the process.

Manual valve (Stainless steel)	P/N
DN 50 ISO-KF	30501M
DN 100 ISO-K	30503M

Electro-pneumatic valve (Stainless steel)	P/N
DN 50 ISO-KF	30501E
DN 100 ISO-K	30503E

* Power supply is a customer supply.

Fitting accessories

Several fitting accessories are available in the manufacturer's catalog (fitting rings, valves, bellows...).

"Anti-noise" device

This accessory reduces the vibrations transmitted to the exhaust line during cycle pumping at atmospheric pressure.



P/N
109418

Inlet pipe

In order to facilitate the pump connection to the pumping installation, a stainless steel pipe can be installed at the ACP 120 inlet.

This accessory is also proposed in option in the ordering configurator.

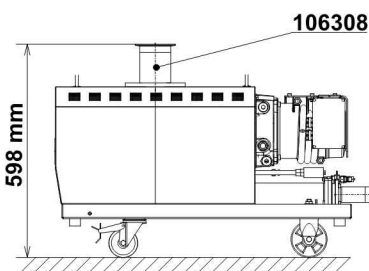

Stainless steel pipe	P/N
DN50 ISO-KF length: 129 mm	106308

B

Start-up

Operating instructions – ACP 120 / ACG 600

B 000	<i>Safety instructions</i>
B 010	<i>Handling/ Unpacking / Storage</i>
B 020	<i>Positioning the pump in the pumping installation</i>
B 025	<i>Filling the machine oil housings</i>
B 030	<i>Connection to the cooling circuit</i>
B 040	<i>Inert gas purge connection ("G" version)</i>
B 050	<i>Electrical connection</i>
B 051	<i>Checking the direction of rotation at initial pump start-up</i>
B 060	<i>Connection to the pumping circuit</i>

Safety instructions

Refer to the Symbol meaning at the beginning of this manual.

Overview

We took care to provide you with a clean product. To keep it in this condition, unpack it only in its final place of use.

Contact in case of emergency

For emergencies and breakdowns, contact the manager of your local service center (see addresses at back of manual or on our website).

Make sure the equipment shows no sign of transport damage. If it has been damaged, take the necessary steps to record this with the carrier and inform the manufacturer. In all cases, we recommend keeping the packaging (reusable materials) for further transport of the equipment or for prolonged storage.

Our products are designed to comply with current EEC regulations. Users making their own modifications to the product are liable to break its compliance with these regulations, degrade its EMC (electromagnetic compatibility) rating, and make it unsafe to use. The manufacturer declines all liability for the consequences of such operations.

CAUTION

The product's EMC rating is obtained on the understanding that it is installed in compliance with EMC rules.

Of special note: in environments that are prone to emit interference, use shielded cables and connections on interfaces

WARNING

Heavy product

This product needs special handling precautions due to its weight. It should be removed from its crate only by staff trained in heavy materials handling: use the lifting rings and devices provided with the product. The maker can not be held liable for the consequences of using other rings.

WARNING

Although the product meets EEC safety regulations (topple angle $\pm 10^\circ$), it is advisable to guard against the risk of tilting during handling, installation, and use.

Refer to chapter A of the operating manual for location of the center of gravity.

Safety instructions

CAUTION

Ensure that the product is connected to an electrical installation:

- in compliance with the local and national safety requirements,
- equipped with electrical protection (fuses, circuit breaker, ...) which has a suitable earth (ground) point, properly connected

WARNING

Electric shock hazard on touching.
When the main isolator is switched to the «0» position, items located between the mains connection and the isolator are still under mains voltage.
Disconnect the mains cable from all power sources before commencing any maintenance work on the product.

WARNING

Electric shock hazard.
Some components have capacitors charged to over 60VDC. When power is switched off, they keep their charge for a time. Residual voltages from the filter capacitors can cause electric shocks all the way back to the mains plug. Wait 5 minutes after power-off before commencing any work on the product.

CAUTION

Lock out/tag out (LO/TO) device.
In order to properly secure the pump for installation and/or maintenance, it is required to lock out/tag out the pump properly in accordance with OSHA requirement 29 CFR.1910.147.

DANGER

If loss of purge flow creates a significant risk, then the purge flow must be monitored externally and a response to loss of purge flow must be provided by the process equipment and interlocked if necessary.
If pyrophoric materials above the LEL are sent to the pump then nitrogen should be supplied at a rate to ensure that concentration is diluted to be below the LEL, in addition an interlock should be provided to ensure that gas flow to the pump is stopped when nitrogen is lost.

WARNING

If loss of cooling water creates a significant risk, then the water flow must be monitored externally by the process equipment.

DANGER

If any corrosive, reactive, flammable, pyrophoric, oxidizing processes can be sent to the pump, then an exhaust monitor should be used in the secondary exhaust to ensure that gas flow to the pump is stopped when secondary exhaust is lost.
In addition an interlock should be provided to ensure that gas flow to the pump is stopped when nitrogen is lost.
If flammable materials are sent to the pump, the customer will need to provide a hardware based LEL detection in the secondary exhaust (capable of detecting at 25% of the LEL) that will stop chemical supply to the pump when gas is detected at 25% of LEL for that flammable material.

Safety instructions

WARNING

Lock out/tag out (LO/TO) water and N₂ supplies.

The end user needs to provide a dedicated source of water and Nitrogen equipped with a manual valves that can be locked out within 10 feet of the tool.

WARNING

Other located hazardous energies

Water cooling circuit and nitrogen purge are pressurized hazardous energies. Release pressure before servicing:

- for the N₂ purge, disconnect the gas line quick connector and turn off the pressure regulator by turning the knob counter-clockwise;
- for the water cooling circuit, disconnect the input connector and leave the output connected. Wait 1 minute before disconnecting the output.

WARNING

As loss of cooling water creates a significant risk for the pump, regularly check the right operation of the cooling circuit.

WARNING

The products are designed to avoid subjecting users to heat hazards. However, specific operating conditions may exist that require extra caution from users due to the high temperatures (outer surfaces > 70° C on the exhaust pipe),

Wear protective gloves and leave the pump to cool before working on the product.

WARNING

The user and /or OEM are ultimately responsible for operating the equipment in a safe manner. The manufacturer has no control over the types of gases exposed to this pump. This is the user and/or the OEM's responsibility to follow the necessary safety requirements.

Frequently process gases are toxic, flammable, corrosive, explosive and/ or otherwise reactive.

Toxic gases can cause serious injury or death. Operators and users must take the appropriate safety recommendations to prevent injury. Consult the responsible department for instructions and safety information.

Hazardous gases through the pump can cause serious injury or death. It's mandatory by regulations to connect the pump's exhaust to a facility hazardous gas exhaust system which incorporates appropriate filters, scrubbers, etc. This system must meet all air and water regulations.

Check that pump is correctly connected to the equipment (B 60).

Safety instructions

WARNING

Safety interlock

The pump motors are protected against overload through circuit breakers which may include solid state components, refer to electrical schematic.

These interlocks must never be overridden during installation, use or maintenance.

Once activated, power will be switched off and the pump will be put in a safe condition. When a fault occurs, the cause must be corrected before the fault can be cleared. To clear the fault, it is required to switch power off, main switch to "0" position, before opening the electrical box and unlock the circuit breakers.

WARNING

Do not expose any part of the human body to vacuum.

The product is supplied with the inlet and exhaust sealed. Remove these blanking plates when you are ready to connect the product on your vacuum system.

As well as, don't operate the product unless the inlet and exhaust are connected to a vacuum and exhaust pumping line.

WARNING

The products are factory tested to ensure they will not leak in normal operating conditions. It is the user's responsibility to ensure this level of leak tightness is maintained.

WARNING

Any intervention must be done by safety trained personnel only (EMC, electrical safety, chemical risk,...). Before performing any maintenance operations on the product, isolate the product from the various energy sources (electricity, compressed air, ... etc).

Whenever you return the product to an adixen repair service center, please make sure you follow the "procedure for returning products" and fill in the declaration of contamination found on our website.



Handling / Unpacking / Storage

Handling

Make sure the equipment shows no sign of transport damage. If it has been damaged, take the necessary steps to record this with the carrier and inform the manufacturer. In all cases, we recommend keeping the packaging (reusable materials) for further transport of the equipment or for prolonged storage.

⚠ WARNING

Although the product meets EEC safety regulations (topple angle $\pm 10^\circ$), it is advisable to guard against the risk of tilting during handling, installation, and use. Refer to chapter A of the operating manual for location of the center of gravity.

Packaging dimensions and weight

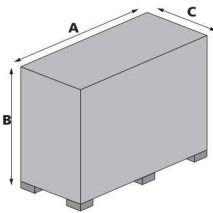

Model	Dimension				Weight (kg)	
	Unit	A	B	C	Unit	
ACP 120	mm	1170	905	590	kg	230
	inch	46	36	23	lbs	507
ACG 600	mm	1170	1200	590	kg	345
	inch	46	47	23	lbs	760

Tolerance: ± 20 mm.

Unpacking

Open the crate

- Unscrew the fixing screws of the crate cover.
- Remove the cover of the crate.
- Unscrew the fixing screws of the four strengthening piece (on the external sides of the crate).
- Remove the four strengthening piece.
- Remove additional packages from the crate and set aside.

Packaging contents

- 1 operating instructions
- 1 x 0.4 liter oil filling (ACP 120)
- 3 x 0.4 liter oil filling (ACG 600)
- 1 funnel and its flexible tube, P/N 107381
- 1 x 1/4 NPT female quick connector, P/N 076720
- 1 x 1/4 NPT male quick connector, P/N 076721
- 2 x 1/4 BSPP adaptor, P/N 106089
- 1 x 1/8 NPT female quick connector ("G" model), P/N 107142
- 1 OD adaptor for 6.35 mm tube ("G" model), P/N 076923.



Handling / Unpacking / Storage

Handling the pump to remove it from the crate



WARNING
HEAVY OBJET
 Can cause muscle strain or back injury.
 Use lifting aids and proper lifting techniques when removing or replacing.

Located on the upper cover, this label indicates that due to its heavy weight, the product should not be handled manually, but always through appropriate handling devices.

WARNING

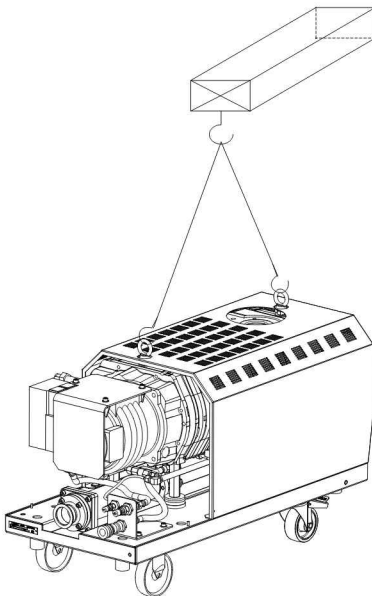

Heavy product

This product needs special handling precautions due to its weight. It should be removed from its crate only by staff trained in heavy materials handling: use the lifting rings and devices provided with the product. The maker can not be held liable for the consequences of using other rings.

It is highly recommended that a hoist is used for lifting with the following specifications:

- Length for each arm must be > **500 mm** (20 inch).
- Rated capacity for each arm must be > **350 kg** (20 lbs).

Model	Weight (kg)	Weight (lbs)
ACP 120	205	452
ACG 600	320	772

For handling of the pump, use the hoisting rings or device provided for this purpose.

Equipment storage

CAUTION

When the pump is new, if it is going to be put into storage, the inlet and exhaust seals should be left in place because the pump has been pressurized with dry nitrogen to prevent humidity from entering. Our equipment can be stored without particular storage precautions (pump pressurized in nitrogen and sealed) only at an ambient temperature between - 25°C and + 55°C.

If the inlet and exhaust blanking plates have been removed, there is a risk of internal part corrosion. We advise:

- to pressurize the pump with Nitrogen or dry air (200 hPa relative pressure),
- to seal the inlet and exhaust ports,
- and to store it at an ambient temperature between - 25°C and + 55°C, for a period of 1 year maximum.

Never store a pump which has been used. Return it to an adixen repair service center (refer to **E 10**).



Positioning the pump in the pumping installation

⚠ WARNING

Risk of tilting

Don't place the product on a tilted surfaces, it can drag the operator along due to its heavy weight:

- use castors to move it on short distances,
- locate it on flat, hard ground,
- do not push it sideways
- adjust the levelling feet for operation to make sure that the pump is not supported by the castors.

The product is not designed to carry people or loads and is not for use as a seat or step.

⚠ CAUTION

Pump performance will depend on the kind of accessories used and the quality of the mechanical connections such as the pump fittings.

As these pumps are typically used in a corrosive atmosphere, their reliability will depend on proper installation and maintenance. When assembling the vacuum circuit, we recommend the installation of maintenance accessories such as shut-off valves on the inlet and purge lines.

For safety reasons, use accessories on the inlet and exhaust lines whose materials and sealing properties are compatible with the gases being used.

Positioning the pump

CAUTION

The product must be operated in the horizontal position in support on its feet, with the pumping axis vertical and the inlet operating upwards.

Determine where the pump will be placed.

Refer to the technical specification section for dimensions, if needed (see **A 40**).

Use the handling devices to position the pump in the desired location, (see **B 10**) or a lift truck.

Lock the casters (inlet side). The pump is equipped with four locking screw jacks.

Lock the pump by adjusting these jacks so that all four feet are resting solidly on the floor.

Unscrew and remove the ACP 120 inlet side lifting ring.

⚠ CAUTION

Risk of trips.

Route and secure cables, hoses and pipework during installation to avoid any possible risk of trips.



Filling the machine oil housings

CAUTION



Risk of oil inhalation

The pumps are delivered without an oil charge: the oil is delivered in separate containers.

Wear gloves, protective glasses to fill in or drain the oil in the pumps.

Our pumps are tested in the factory with adixen's oil: it is mandatory to use the same oil during operation.

It is recommended to request information from the manufacturer on the safety data sheets concerning the lubricant (MSDS available on our website).

CAUTION

Mineral and synthetic oils must not be mixed together. Contact the manufacturer or your service agent before making any changes.

Oil quantities

Pump model	Quantity (liter)				Nber of can 0,4 L
	ACP 120	Roots housing		Total	
		gears side	motor side		
ACP 120	0.35	-	-	0.35	x 1
ACG 600	0.35	0.45	0.25	1.05	x 3



Filling the machine oil housings

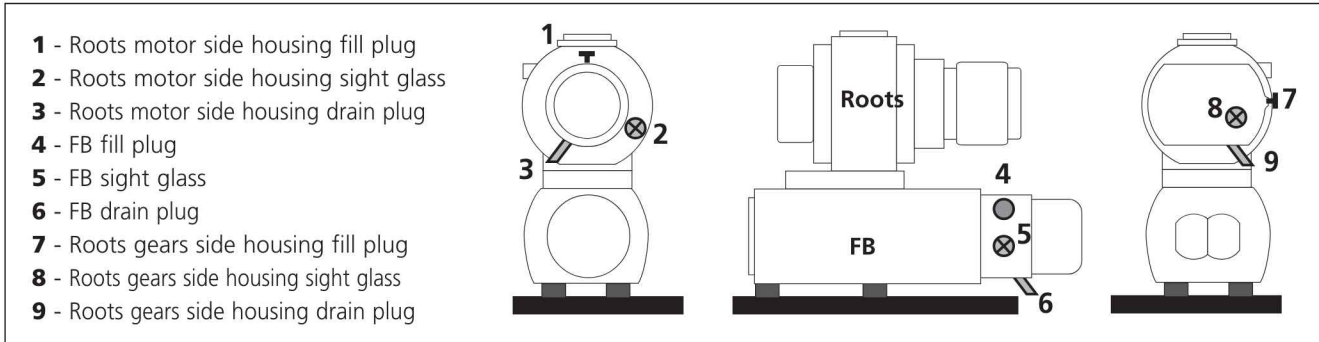

Filling procedure

Make sure the pump is off, (main switch to "0" position) and then remove the pump covers. **Position the pump horizontally.**

Use the funnel equipped with a flexible tube delivered with the pump.

Filling of the Roots motor side housing

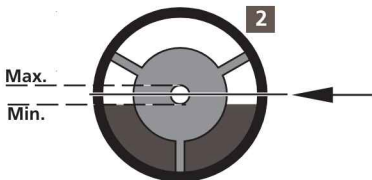

Remove the fill plug (1). Position the funnel in the oil fill neck. Fill the pump with oil according to the recommended quantities.

Do not exceed the indicated quantities. The oil level should be in the middle of the sight glass (2). For this to be accurate, wait a few minutes for the oil to settle over all internal surfaces.

Replace the fill plug securely.

Filling of the Roots gears side housing

Remove the fill plug (7). Position the funnel equipped with flexible tube in the oil filler neck. Fill the pump with oil according to the recommended quantities.

Do not exceed the indicated quantities. The oil level should be in the middle of the sight glass (8). For this to be accurate, wait a few minutes for the oil to settle over all the internal surfaces.

Replace the fill plug securely.

Filling of FB

Remove the fill plug (4). Position the flexible tube in the oil fill neck. Fill the pump with oil according to the recommended quantities.

Do not exceed the indicated quantities. The oil level should be in the middle of the sight glass (5). For this to be accurate, wait a few minutes for the oil to settle over all internal surfaces.

Replace the fill plug securely.



Connection to the cooling circuit

Water characteristics

In order to limit corrosion and motor cooling circuit clogging, it is recommended to use cooling water with the following characteristics:

- Treated soft water or non-corrosive industrial water
- pH between 7.5 and 11
- Hardness < 7 milli-equivalent/dm³
= 350 mg/l of CaCO₃ (calcium carbonate)
= 35 °f (French degree)
- Resistivity: 20000 Ω.cm > R > 1500 Ω.cm
- Particles maximum size: 0.2 mm
- Solid pollution < 100 mg/dm³
- Temperature from 10 to 25 °C
- Relative pressure range between 2 · 10³ and 6 · 10³ hPa (29 to 87 psig)
- Pressure Δ inlet/outlet: 2 · 10³ hPa minimum (29 psi)
- Water flow: **see A 40**

If the "solid particle size" and "solid pollution" water characteristics values can not be reached, install a filter on the cooling connection.

CAUTION

The use of uncontrolled city water can lead to water circuit clogging due to limestone deposition, which may necessitate in the worst case a complete cleaning and overhaul of the cooling circuit..

CAUTION

The presence of micro-organisms like aquatic weed and micro-biological substances like bacteria can lead to cooling problem in the pump. Appropriate water treatment system need to be use to prevent such growth of micro-organisms.

Mounting recommendations

We recommend to equipped the cooling circuit requirements with a regulator valve (customer supply).

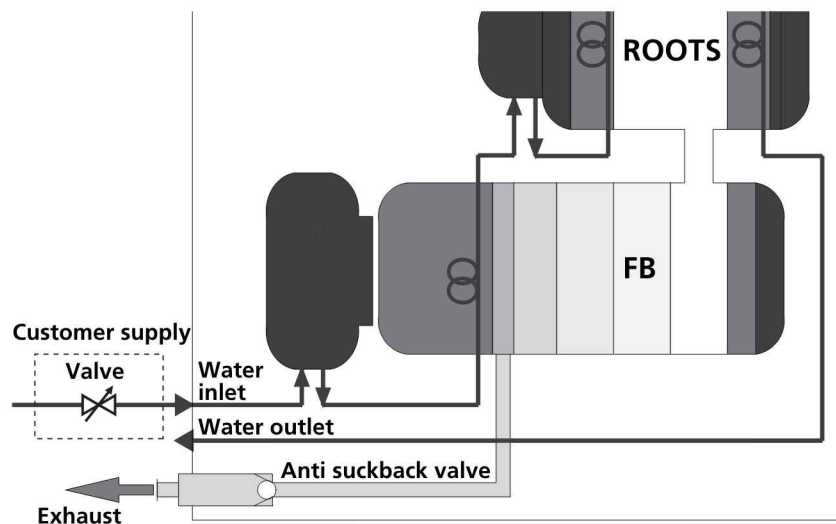



Connection to the cooling circuit

Water cooling quick connection

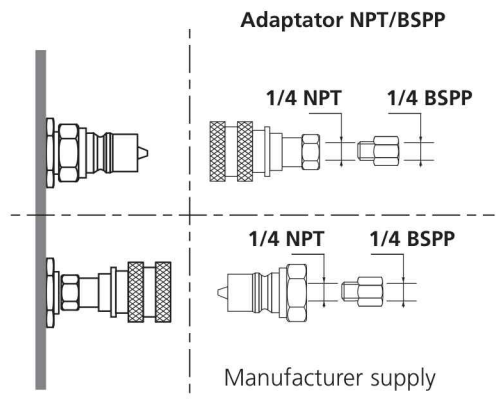
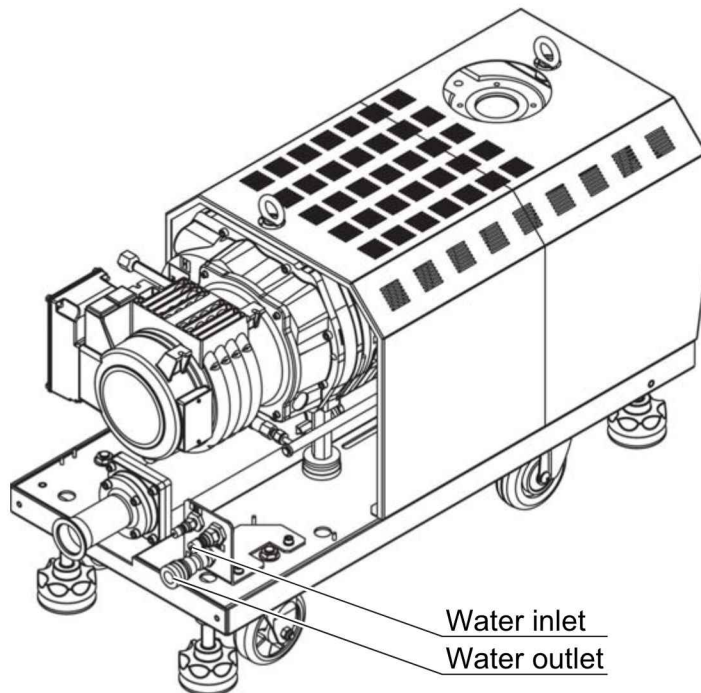

Install the two 1/4 BSPP adaptators, packaged separately, on the 1/4 NPT quick connectors.

Connect the water pipes:

- Water inlet marked "IN": 1/4 NPT quick female connector,
- Water outlet marked "OUT": 1/4 NPT quick male connector.



Inert gas purge connection ("G" version)

Nitrogen characteristics

For maximum performance, a **filtered dry nitrogen supply** with the following characteristics is required:

- H₂O concentration : < 10 ppb
- O₂ concentration : < 5 ppb
- Dust < 1 μm
- Oil < 0.1 ppm
- Relative pressure range between 2 - 6 · 10³ hPa (30 to 87 psig)

Depending on the process, the purge of gaz should be adjusted according to one of the following table's figure. Please contact manufacturer application service to define this figure.

Pressure (hPa)	0.7 · 10 ³	1.4 · 10 ³	2 · 10 ³	2.6 · 10 ³	3.2 · 10 ³
Flow (slm)	20	30	40	50	60

Mounting recommendations



A sudden inrush of N₂ into the pressurization circuit may result in damage to internal parts.
 We recommend to equipped the N₂ circuit requirements with pressure regulator and manometer (customer supply).
 Close the pressure regulator before pressurizing the circuit.

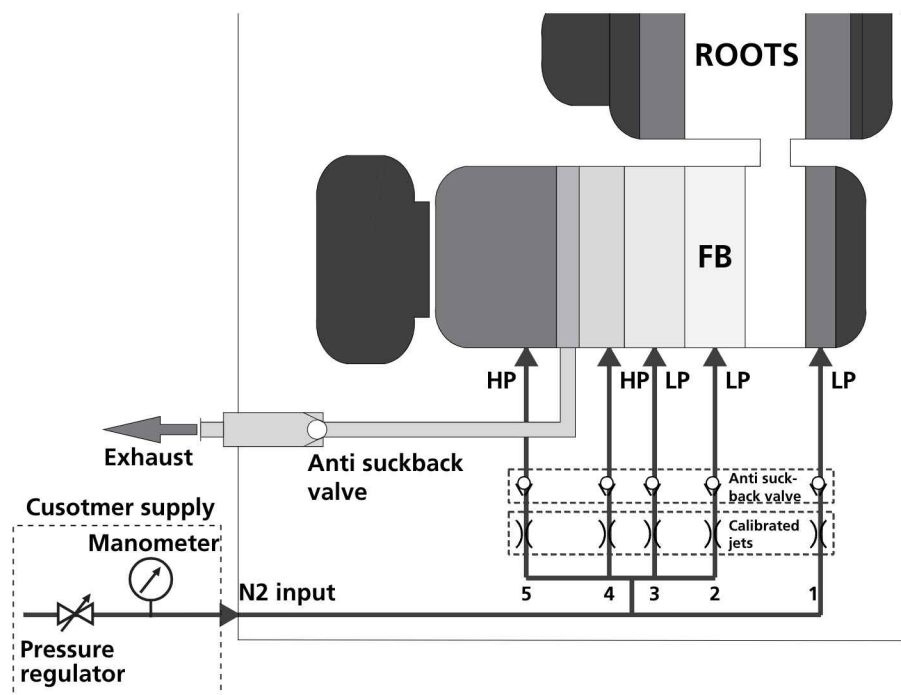



Inert gas purge connection ("G" version)

Connection

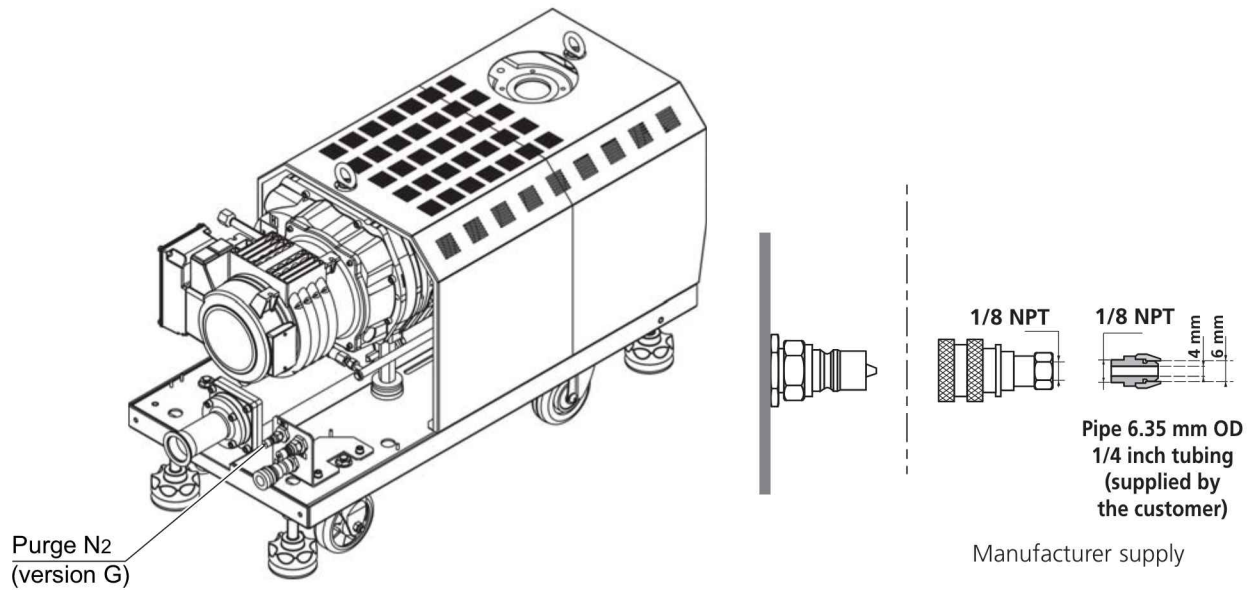

Install the OD adaptor packaged separately, on the 1/8NPT female quick connector.

Connect the N₂ pipe line to purge connector marked "**N₂**".



Electrical connection

It is necessary to carry out the wiring of the two motors of the group ACG 600. By way of example, a wiring diagram is proposed in *G 110*.

Make sure that main switch is off during electrical connection. Study the preliminary precautions (see *B 00*).

Customer electrical installation protection

WARNING

In the three phase electrical installation, the customer must provide a circuit breaker, easily accessible by an operator and visibly marked as a electrical interrupting device of the product. It must be in accordance with local regulations.

Installation protection with circuit breaker

The user must supply the pump from facilities equipped with main circuit breaker, curve D (IEC 60947-2), in accordance with local regulations.

Main circuit breaker rating (recommended values).

Model	Circuit breaker rating	
	220-230V LV	380-480V HV
ACP 120	15 A	10 A
ACG 600	25 A	15 A

CAUTION

 An IEC 417#5019 symbol is located on the rear panel for the main power supply earth terminal.

Ensure that the equipment and the electrical supply cable are suitably protected against earth defects and that the earth wire is longer than the three conducting wires.

The user must provide a second protective earth (ground) conductor with a cross-sectional area at least equal to the conducting wire size. Then, connect the protective earth stud to the suitable installation earth point.

CAUTION

Risk of tearing

Route and secure electrical cables in cable channels to avoid possible risk of tearing.



Electrical connection

Motor wiring

Motor characteristics

	V	Hz	min-1	kW	cos φ	A
Δ	200	50	2820	1.5	0.84	5.70
Δ	240	50	2850	1.5	0.76	5.50
λ	380	50	2835	1.5	0.84	3.20
λ	415	50	2850	1.5	0.76	3.20
Δ	200	60	3420	1.5	0.90	6.20
Δ	240	60	3435	1.5	0.85	5.60
λ	380	60	3420	1.5	0.88	3.40
λ	480	60	3440	1.5	0.77	3.20

Motor coupling

At factory, the motor(s) is/are coupling in star.

Check that the coupling of motor is in conformity with the mains voltage. If it is not the case, change the coupling in function of the following schemas.

Star connection

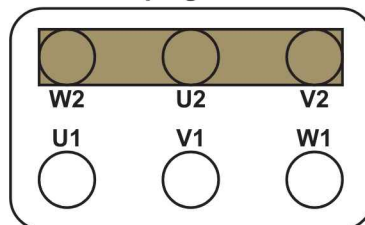

Triangle connection

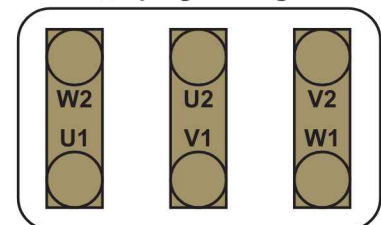

Motor electrical connection

Outside diameter of the mains cable: 6 mm (cable customer supply).

8 Open the electrical cabinet.

Pass the cable through the feedthrough provided of this purpose.

Connect the mains cable to the motor main disconnect switch.

Connect the ground to the separate terminal bar.

Check that the cable is correctly protected against ground defects.

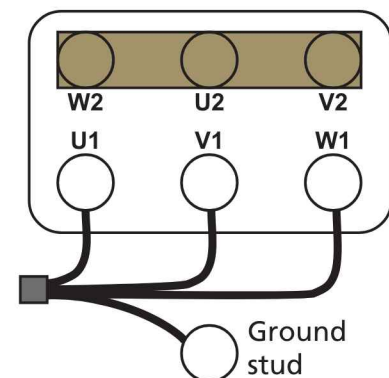

WARNING

The connection to the mains must be done according to CEI 60309. Provide a permanent electrical connection that can't be disconnected without using a tool.



Electrical connection

Temperature sensors electrical connection

The pump is equipped with 3 temperature sensors: 100, 120 and 150°C.

There are NC dry contacts, to be powered through a customer supplied relay.

8 Open the electrical cabinet.

Pass the cables through the feedthrough provided of this purpose.

Connect the cables to the temperature sensors main disconnect switch.

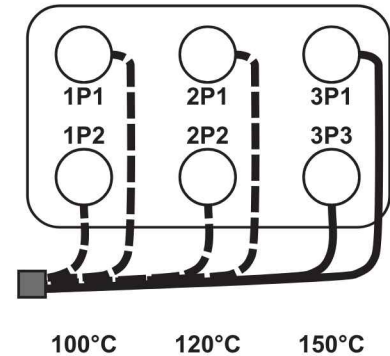

⚠ WARNING

It is recommended to wire the 100°C thermal switch in order to trig a warning in case of overheating (see *G 110*)
This wiring should be performed by the customer.

⚠ WARNING

It is compulsory to wire the 120°C thermal switch in order to cut the motor(s) power in case of overheating (see *G 110*).
This wiring should be performed by the customer.

ACG 600 only

It is recommended to delay the Roots starting of approximately 3 seconds after ACP 120 starting.



Checking the direction of rotation at initial pump start-up

Before using the monitoring, check that the mechanical and electrical connections defined in the chapter B have been made.

CAUTION

Before each pump start-up, check that oil levels of ACP 120 and Roots (ACG 600) housings are visible in the middle of the sight glasses: do this check with the pump stopped.

WARNING

In order to prevent moisture from entering the pump before installation, it has been pressurized before shipment with nitrogen and sealed with blanking plates.

Do not remove these blanking plates until you are ready to install the product on your vacuum system.

Check the direction of rotation at initial pump start-up

DANGER

At the initial start-up, provide protection against the risk of crushing related to the rotating parts in the inlet.

A non-powered Roots can be driven by another pump in rotation (risk of crushing). Always connect the pump inlet port before starting the pump.

ACP 120 pump

Remove the blank-off flange on the inlet and exhaust port.

Fit a pressure gauge at the pump inlet.

Start-up the ACP 120 pump alone, then stop it after few seconds:

- if the indicated pressure is less than $5 \cdot 10^{-1}$ hPa, the direction of rotation is correct.
- if the pressure increases, invert two phases from motor terminal (see **B50**).



Checking the direction of rotation at initial pump start-up

ACG 600 pump

Check the standalone ACP 120 direction of rotation according to the procedure described above.

When the direction of rotation is correct, start the Roots (ACP 120 is in operation).

Check the Roots direction of rotation according to the procedure described above.

The measured pressure must be lower than the pressure when the ACP 120 is standalone.

As soon as the installation and start-up procedure is complete, and the direction of rotation is checked, (see **B 10** to **B 51**), the pump is ready to be connected to the pumping line (see **B 60**).

⚠ WARNING

The voltages and currents in use can induce electric shock. Isolate and lock out power to the product before maintaining it / or removing the cover. Only skilled, authorized people may carry out maintenance work.

⚠ WARNING

Electric shock hazard. Some components have capacitors charged to over 60VDC. When power is switched off, they keep their charge for a time. Residual voltages from the filter capacitors can cause electric shocks all the way back to the mains plug. Wait 5 minutes after power-off before commencing any work on the product.

CAUTION

In order to prevent foreign bodies from entering the pump, while waiting to be installed, replace blanking plate on inlet and exhaust ports again.



Connection to the pumping circuit

Make sure the direction of rotation has been checked (see **B 51**).

WARNING

Do not expose any part of the human body to vacuum.
The product is supplied with the inlet and exhaust sealed. Remove these blanking plates when you are ready to connect the product on your vacuum system.
As well as, don't operate the product unless the inlet and exhaust are connected to a vacuum and exhaust pumping line.

The vacuum pump is also a compressor: incorrect use may be dangerous. Study the operating manual before starting up the pump.

Preliminary precautions for inlet and exhaust connections

CAUTION

For safety reasons, use accessories on the inlet and exhaust lines whose materials and sealing properties are compatible with the gases being used.

Components	Material
Pump, inlet, exhaust	Stainless steel, cast iron
O-ring, shaft seals	Fluorinated elastomers, PTFE, FPE, stainless steel,

It is recommended to be able to isolate the pump from the vacuum and exhaust line, particularly if you pump on corrosive gases (inlet and exhaust isolation valves, purges,...).
Several fitting accessories are available in the manufacturer's product catalog.

Incorporate flexible stainless steel flanged bellow in the vacuum and exhaust pump line to reduce the transmission of vibration.

After connecting the product to the pump ing line, check for leaks along the entire line to ensure proper connections (pump, pipes, valves, etc.).



Connection to the pumping circuit

At the pump exhaust

⚠ WARNING

Exhaust of corrosive, reactive, flammable, pyrophoric or oxidizing process gases may result in severe injury or death.
Always connect the pump exhaust to an exhaust extraction system.

⚠ WARNING

Ensure that all components in the exhaust pipeline have maximum pressure rating which is greater than the highest pressure that can be generated in your system.

Connection DN 40 ISO-KF

At the pump inlet

⚠ CAUTION

Make sure that the parts or chambers connected to the inlet of our products withstand a negative pressure of $1 \cdot 10^3$ hPa in relation to the atmospheric pressure.

Connection DN 50 ISO-KF (ACP 120)
DN 100 ISO-K (ACG 600)

Inlet isolation valve (accessory)

This accessory avoids a sudden reverse flow of gas to the chamber when the pump is stopped.

Connect the isolation valve between the pump inlet and the chamber (as close as possible to the inlet) using connecting accessories.



Operation

Operating instructions – ACP 120 / ACG 600

C 000

Safety recommendations for harsh processes

C 010

Use of the pump

Safety recommendations for harsh processes

Shutdown procedure for discontinuous operation

All process pumps are designed for continuous operation in pumping process gas and should not be stopped.

adixen Vacuum Products will be released from any warranty and liability claims if a process pump is stopped for a prolonged time leading to condensation of by-products, powder build-up or corrosion inside the pump.

The only guaranteed solution by adixen Vacuum Products to restart a process pump after a prolonged stop is to perform a complete overhaul of the pump.

Despite this recommendation, if the pump is shut down for a prolonged time, it is advisable to follow the precautions below-mentioned in order to reduce the risks of condensation, powder build-up and corrosion inside the pump.

- From the process chamber, flush the pump using a dry inert gas, such as Nitrogen, through the inlet port during 30mn.
- Stop inert gas supply and let the pump running at ultimate pressure for 5 minutes.
- Stop the pump and close inlet port with the appropriate blank-off flange
- If pump is equipped with a monitoring system, configure N2 prolonged option in the menu and set it on 30mn, then perform a cycle start/stop of the pump. Wait till end of purge prolonged cycle (30mn).
- Put appropriate blank-off flange at exhaust of the pump.
- Turn off the cooling water supply.

When the pump will need to be back in operation, the following points need to be observed:

- Remove the exhaust and inlet blank-off flanges and connect the pump to the equipment.
- Turn on the cooling water.
- Power on the pump and press start button.

In case of trouble to restart the pump, contact **adixen customer service**.

Safety recommendations for harsh processes

CAUTION

Safety information related to SiH_4/H_2 processes

Processes using high H_2 or SiH_4 flows require extended safety to prevent any problem. In order to avoid any safety issue or risks relative to process and pumping conditions, it is necessary to set up the pump with correct settings, following adixen recommendations.

Concerned processes : PECVD Si : (a/ $\mu\text{c-Si}$ using both SiH_4 and H_2) ; PECVD SiN (using SiH_4)

On these applications, and depending on working conditions (flows ratio and working pressure), these risks can easily be identified.

- Explosion of Si dust (only on PECVD Si)
- Ignition of SiN powders (on PECVD SiN, when NH_3/SiH_4 ratio < 1)
- Ignition of SiH_4/H_2 trapped into powders.

1 - Explosion of Si dust : (PECVD Si)

Some PECVD Si produces a lot of an orange/brown powder which is composed of very thin particles of Si. Depending on exact process conditions, size of these particles may vary from 0,1 to 100 μm .

Available ignition sources sufficient to ignite:

- > Electronic charges loaded into particles naturally generated by plasma into process chamber
- > Friction between particles or air flow inrush
- > Local elevated temperature due to mechanical contact
- > Auto-ignition when Si dust produced in anaerobic conditions is violently put in contact with O_2 is also possible

Overpressure generated by this kind of mix explosion/detonation is 10 to 11 times initial pressure.

2 - Explosion due to ignition of SiH_4 trapped in by-products : (PECVD Si & SiN)

Another well known phenomena is explosion due to trapped silane or poly-silane polymers. As PECVD Si and SiN produce a lot of powder which deposits into vacuum line, pump, exhaust line... the different layers of powder have the ability to retain/trap or desorbs flammable process gases (like Hydrogen & Silane).

In case of violent air inrush, a cloud may be generated. Trapped flammables gases can be released suddenly and ignite.

3 - Explosion consequences:

An explosion, either in vacuum line or pump or exhaust line, is a complex chemical reaction. An explosion can also generate a leak which which then could generate a second explosion due to the additional air ingress.

Another important point is that vacuum pumps are also compressors. Depending on pressure in volume to evacuate, pressure in different pump's stages can be much greater than Atmosphere. Consequently, explosion can generate high local overpressure (ie $25 \cdot 10^3$ hPa may be locally reached with an initial pressure of $2.5 \cdot 10^3$ hPa obtained in the primary dry pump when the complete pumping system is exposed to 1 Atm at inlet).

Safety recommendations for harsh processes

CAUTION**Safety information related to SiH₄/H₂ processes
(cont.)****GENERAL RECOMMENDATIONS**

It is necessary to pay particular attention to:

Leak tightness of the whole system:

- Be sure there is no air leak on pumping system itself and on vacuum line. Leak rate has to be lower than $1 \cdot 10^{-6}$ hPa l/s of Helium. Air ingress to inner side may lead to uncontrolled reaction between SiH₄ and O₂. If the leak is big enough, H₂/O₂ mix could be ignited by decomposition of SiH₄. In the worst case, explosion can occur.
- End user must guarantee vacuum line and exhaust line leak-tightness.
- Be sure there is no leak at pump exhaust. An overpressure Helium leak test has to be performed. Maximum leak rate is $5 \cdot 10^{-5}$ hPa l/s from pump exhaust to Abatement system inlet.

N₂ purge:

- Be sure pump is purged with N₂. **Air is prohibited.**
- This purge needs to be maintained at any time to avoid air back streaming likely to enter in contact with flammable deposits.
- This purge could be exceptionally stopped when process gases are off and full system has been flushed with nitrogen. This has to be secured in a safe and robust procedure.
- Be sure N₂ purge warning and alarm are enabled and properly interlocked with the process equipment.
- Be sure N₂ purge is prolonged at least 10 min after pump stop in order to evacuate residual process gases after pump stop.

Process line (from process chamber to abatement inlet) opening before the end of previously described purge must be strictly prohibited.

Communication with tool:

- global warning and alarm and specific N₂ warning and alarm has to be sent to the tool which must shut off active gases.
- Immediate corrective actions must be scheduled in case of N₂ warning or alarm signals

Safety recommendations for harsh processes

CAUTION

Specific adixen recommendations for processes using SiH_4 and H_2

For these applications, using SiH_4 or H_2 , adixen recommends:

- 1) To avoid O_2 in process vacuum line after process chamber maintenance : O_2 may likely react with trapped gases and deposited dusts & polymers.

Preferred solution:

adixen V acuum Product strongly advise to use separated 'load lock & transfer' (clean) pump in order to evacuate process chamber from atmospheric pressure down to 60 hPa (or less), using a soft pumping step to limit particle transportation.

Alternative solution:

End User may flush process chamber and piping installation with nitrogen in order to decrease oxygen concentration below MOC/LOC level with safety margin (ie $[\text{O}_2] < 2\%$ for hydrogen or 0.84 % for Silane).

- 2) To avoid air inrush in vacuum line: A sudden air inrush could shake the fore line strong enough to make powders fall and release pyrophoric gases. It could also lead to cloud creation which can be ignited easily with very low energy.
 - Avoid ports on the fore line between process chamber and process pump, or secure them (i.e. a valve must be equipped with a blank-off flange and a clamp which cannot be opened without a tool)
 - Use a main isolation valve which cannot be opened if the differential pressure is too high, meaning that only a soft pumping valve can be used to evacuate the chamber from atmosphere
 - To use an efficient flow restriction (i.e. soft pumping) for chamber evacuating from Atmosphere down to 60 hPa: In order to avoid cloud formation within flammable range of common species
- 3) To stop Roots interlocked when chamber pressure is higher than safety level of 60 hPa, to avoid:
 - Si particles removal from pipe inner surfaces (generating Si dust cloud)
 - Generating Si dusts cloud due to high turbulences created at rotating parts contact.
 - Possible Roots exhaust overpressure which could increase effects of a possible explosion by increasing the initial pressure.
- 4) To interface pumps with the tool: N_2 warning has to be considered as a safety issue (see interface recommendations) with immediate interlock action on process gases inlet.
- 5) To flush the pump with N_2 (pump running) during at least 20mn before to exchange it
- 6) To install additional protections to avoid projections if any component of the entire system cannot withstand the pressure of an eventual explosion.
- 7) To minimize or secure quantity of inlets ports in the exhaust line which can become undesired leak sources or sudden, air inrush.
- 8) To respect a safety area around the pump of 4m minimum. This will prevent any damage on operators ears due to overpressure shockwave propagation, as well as little fragments ejection - if any.

Use of the pump

Study the preliminary instructions (see **B 00**).

Do not displace a pump in operation.

Preliminary operations

Before to start-up the pump, check that the following operation are finished:

- Filling the machine oil housings **B 25**
- Connection to the cooling circuit **B 30**
- Inert gas purge connection ("G" version)..... **B 40**
- Electrical connection..... **B 50**
- Checking the direction of rotation
at initial pump start-up **B 51**
- Connection to the pumping circuit **B 60**

Pump start-up

Switch on the motor(s).

Pump starts up.

Pumping shut-down

For a "G" version, when the pumping cycle is completed, it is recommended to keep on purging the pump with nitrogen for 30 min. before closing the inlet valve.

Switch off the motor(s).

Pump stops.

Note : If a customer has supplied and connected a water valve (see **B 30**), it is compulsory to close it just after cutting the moto power.

To stop the pumping system for a long period, refer to 'Shutdown procedure for discontinuous operation' safety instructions. (see **C 00**).



Maintenance

Operating instructions – ACP 120 / ACG 600

D 000 *Safety instruction related to maintenance*

D 010 *Maintenance frequency*

D 030 *Diagnosis and trouble shooting*

Safety instruction related to maintenance

This chapter D describes the main preventive maintenance operations and provides a guide for first diagnosis in the event of an incident.

WARNING

Maintenance must be performed by a skilled maintenance operator trained in the relevant health and safety aspects (EMC, electrical hazards, chemical pollution, etc.).
Isolate the product from all energy sources (mains electricity, compressed air, etc.) before starting work.

WARNING

Electric shock hazard.
The voltages and currents in use can induce electric shock.
Isolate and lock out power line by switching off the main isolator before maintaining the product /or removing the cover.

WARNING

Electric shock hazard.
Some components have capacitors charged to over 60VDC. When power is switched off, they keep their charge for a time. Residual voltages from the filter capacitors can cause electric shocks all the way back to the mains plug. Wait 5 minutes after power-off before commencing any work on the appliance.

DANGER

Remaining process gases in the pump may cause severe injury or death. Before removing the pump, continue N₂ flow from the process tool for 30 min. Nitrogen pressure and flow rate should be identical to the programmed values during process.

DANGER

During pump removal, operator could be in contact with process residues on the exhaust which could cause severe injury or death. Ask your safety department for instructions according to the local regulations.

Recommendations



- Purge the installation with dry nitrogen.
- Wear gloves, protective glasses, breathing mask, or any appropriated safety equipment.
- Ventilate the premises well.
- Do not eliminate maintenance waste via standard disposal channels. Have it destroyed by a qualified company if necessary.
- Install the inlet and exhaust blanking plates, thus delivered with the pump or available as accessories (refer to **E 15**).

Safety instruction related to maintenance

WARNING

Insufficient tightness after servicing could result in chemical hazards. Always perform a leak test after maintenance.

The outside of the appliance and control box can be cleaned with a lint free wiper. Avoid using cleaning products that deteriorate printed surfaces and self adhesive labels. All other cleaning operations must be done by our service centers.

Luminosity

Surrounding lighting in maintenance area must be higher than 300 lux to work or perform maintenance on the pump.



Decontamination – product dismantling

According to the regulations 2002/96/CE about Waste of electrical and electronical equipments, and 2002/95/CE about Restriction of Hazardous substances, the manufacturer provides a recycling paid service for the end-of-life of waste electrical and electronic equipment.

Any obligation of the manufacturer to take back such equipment shall apply only to complete not amended or modified equipment, using adixen Vacuum Products original spare parts, delivered by adixen Vacuum Products, containing i.e. all its components and sub-assemblies.

This obligation will not cover the shipping cost to an adixen Vacuum Products take back facility.

Before returning the product, fill in the declaration of contamination form available on our website. Attach it to the product before shipping to the service-repair office closest to you.

Maintenance frequency

The maintenance times are given as an indication.

They can change according to processes and equipments used. In the event of specific applications, contact the manufacturer customer service.

Process types

Processes concerned for standard version:

- clean processes,
- non corrosive gases.

Processes concerned for "G" version:

- pumping of corrosive gas traces,
- pumping of condensable vapor,
- continuing inlet pressure > 50 hPa.

Minor maintenance frequency

Maintenance	Pump version	1.5 years or 13000h	2 years or 17000h
Functional block LP bearings replacement	Standard version		
	"G" version		
Exhaust pipe maintenance	Standard version		
	"G" version		

Maintenance operator skilled on safety aspects (EMC, electrical hazards, chemical pollution) and trained by our repair service center can perform partial maintenance of the product. In this case, the manufacturer declines all liability for the consequences resulting of such operations.

The partial maintenance operations can be also be performed in our repair service centers.

Major maintenance frequency

Pump version	3 years or 26000h	4 years or 34000h
Standard version		
"G" version		

The full overhaul operations must be performed only by manufacturer trained personnel.

Oil change

There is no oil change required on site. Oil change is only performed during pump overhaul by manufacturer trained personnel.

However, we recommend to drain the oil gear box casings before transportation (voir **E50**).



Diagnosis and trouble shooting

Incident	Cause	Troubleshooting
Bad vacuum or no vacuum	▶ Polluted or clogged pump	<ul style="list-style-type: none"> • ACP Maintenance. 🔧 Call customer service.
	▶ Internal oil leak	<ul style="list-style-type: none"> • ACP Maintenance.. 🔧 Call customer service.
Mechanical noise	▶ Damaged ball bearing	<ul style="list-style-type: none"> • ACP Maintenance. 🔧 Call customer service.
	▶ Rotor seizing	<ul style="list-style-type: none"> • ACP Maintenance.(see E 310). 🔧 Call customer service.
	▶ Unsynchronized gears	<ul style="list-style-type: none"> • ACP Maintenance.. 🔧 Call customer service.
Pump does not start	▶ Motor does no start	<ul style="list-style-type: none"> • Check the wirings. • Check the main power.
Pump is stopped	▶ Motor internal temperature is > 150°C	<ul style="list-style-type: none"> • Check the water cooling circuits.
	▶ Other problem	🔧 Call customer service.



Maintenance instructions

Operating instructions – ACP 120 / ACG 600

E 10	<i>Exchange standard repair</i>
E 11	<i>Preliminary precautions</i>
E 12	<i>Draining of the water cooling circuit</i>
E 14	<i>Disconnecting the pump from the installation</i>
E 15	<i>Conditioning the pump for shipping</i>
E 040	<i>Part cleaning and preparation</i>
E 050	<i>Pump draining</i>
E 300	<i>Replacing the LP bearings</i>
E 310	<i>Freeing up the ACP 120</i>
E 1030	<i>Helium test</i>
E 2020	<i>Exhaust pipe maintenance</i>

Exchange standard repair

Exchange standard repair has been detailed into several key steps. These are detailed in specific sheets as listed below.

The key steps must be followed in chronological order:

Preliminary precautions.....	E 11
Draining of the water cooling circuit.....	E 12
Disconnecting the pump from the installation	E 14
Shipping procedure for contaminated pumps.....	E 15
Installing a new pump.....	B 10 to B 60

Preliminary precautions

Users are advised to observe the precautions presented below during any maintenance operation on the pump and, more especially, any operations requiring the disassembly of sub-assemblies.

WARNING

Maintenance must be performed by a skilled maintenance operator trained in the relevant health and safety aspects (EMC, electrical hazards, chemical pollution, etc.).

Isolate the product from all energy sources (mains electricity, compressed air, etc.) before starting work.

WARNING

Electric shock hazard.

The voltages and currents in use can induce electric shock.

Isolate and lock out power line by switching off the main isolator before maintaining the product /or removing the cover.

WARNING

Electric shock hazard.

Some components have capacitors charged to over 60VDC. When power is switched off, they keep their charge for a time. Residual voltages from the filter capacitors can cause electric shocks all the way back to the mains plug. Wait 5 minutes after power-off before commencing any work on the appliance.

WARNING

Other located hazardous energies.

Water cooling circuit and nitrogen purge are pressurized hazardous energies.

Release pressure before servicing:

- for the N2 purge, disconnect the gas line quick connector and turn off the pressure regulator by turning the knob counter-clockwise;
- for the water cooling circuit, disconnect the input connector and leave the output connected. Wait 1 minute before disconnecting the output.

Preliminary precautions

Protection against corrosive gases

DANGER

Remaining process gases in the pump may cause severe injury or death. Before removing the pump, continue N2 flow from the process tool for 30 min. Nitrogen pressure and flow rate should be identical to the programmed values during process.

DANGER

During pump removal, operator could be in contact with process residues on the exhaust which could cause severe injury or death. Ask your safety department for instructions according to the local regulations.

DANGER

Chemical supplies coming from the tool, as well as the water and the nitrogen need also to be locked out/tagged out.

Users are advised:



Stop the pumping system according to "Shutdown procedure for discontinuous operation" safety instructions, see **C00**.

- Wear gloves, protective glasses, any appropriated safety equipment,
- Ventilate the premises well,
- Do not eliminate maintenance waste via standard disposal channels. Have it destroyed by a qualified company if necessary,
- Install the inlet and exhaust blanking plates, thus delivered with the pump or available as accessories (refer to E15).

Luminosity

Surrounding lighting in maintenance area must be higher than 300 lux to work or perform maintenance on the pump.





Draining of the water cooling circuit

Draining Stop the pump and wait its cooling.
Close the water supply.

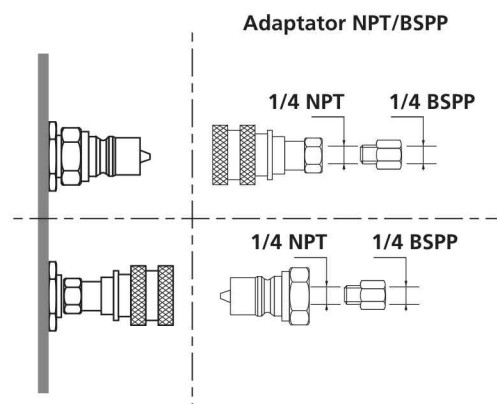
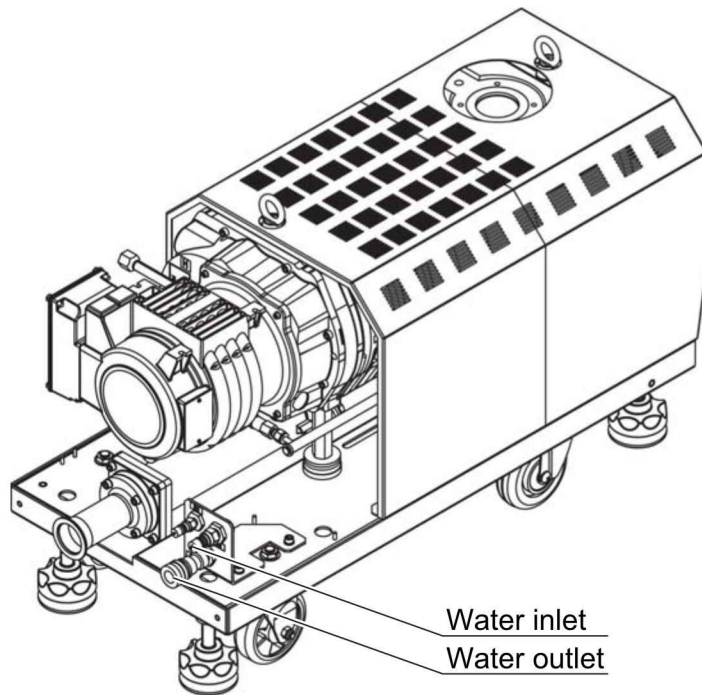

Prepare a flexible pipe (A) with a 1/4 NPT quick female connector (to be connected to the customer compressed air circuit) and another flexible pipe (B) with a 1/4 NPT male connector.

Disconnect **"IN"** and **"OUT"** water connectors on the pump.

Connect pipe (A) at location of **"IN"** and connect the other end to a compressed air circuit ($2 - 5 \cdot 10^3$ hPa).

Connect pipe (B) on the pump, at location **"OUT"** and place the other end of the pipe in a vessel (total water volume will be up than one litre).

When the water is filled out, disconnect pipes (A) and (B).



Disconnecting the pump from the installation

Study the precautions for use first (see **E 11**).

WARNING

The voltages and currents in use can induce electric shock. Isolate and lock out power to the product before maintaining it / or removing the cover. Only skilled, authorized people may carry out maintenance work.

Turning off the pump

Disconnect the mains cable(s) in the motor terminal box(es).

Warning : the ACG 600 is provided with two terminal boxes.

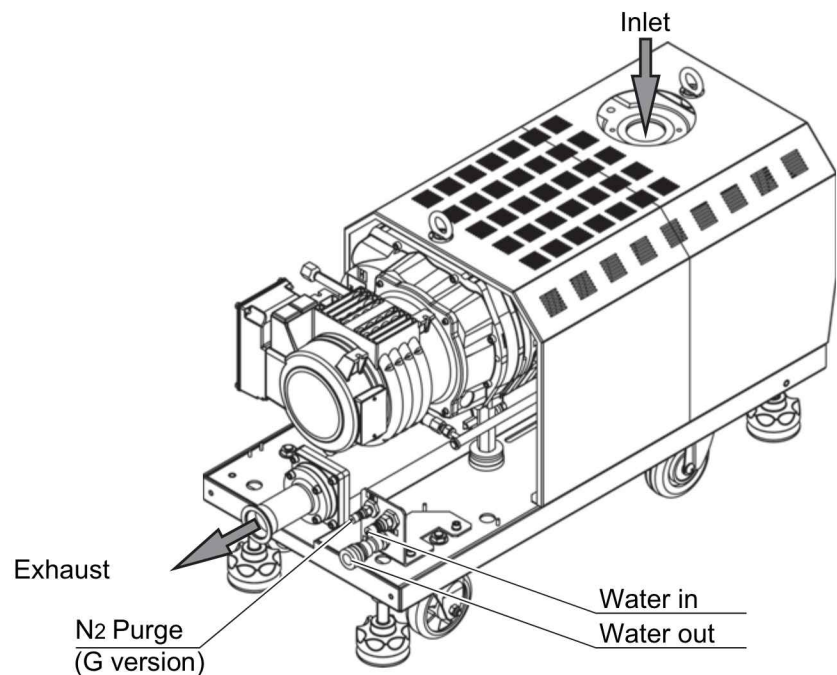

Disconnecting the pump

- Disconnect the N2 purge quick connector.
- Disconnect the water inlet and outlet quick connectors.
- Disconnect the pump from the pumping line.
- Disconnect the pump exhaust.
- Remove the pump from the installation.

Conditioning the pump for shipping

Study the precautions for use first (see **E 11**).

Preparing the pump for expedition

Pumps that are to be shipped must first be decontaminated ("G" version) (see **E 11**) then pressurized with dry nitrogen.

Install the connecting accessories provided with the pump when it was first delivered. Contact the service center for components if necessary.

Inlet	Description	DN 50 ISO-KF	DN 100 ISO-F
	Inlet blank-off flange	087162	107104
	Carriers	106010	/

Exhaust	Description	DN 40 ISO-KF
	Blank-off flange	068197
	Equipped centering ring	068230
	Releasable clamp	303002

Pressurizing the pump

You must have a supply of dry nitrogen to pressurize the pump. See **B 40** for the dry nitrogen's characteristics.

Block the inlet port with the flanges supplied.

Connect the nitrogen to the gas connector.

- Pressurize the pump with dry nitrogen to a relative pressure of 200 hPa.
- When the nitrogen flows out of the exhaust, seal it shut with the accessories provided.
- Disconnect the nitrogen supply.

Fill the declaration of contamination, see **G 200**.

Part cleaning and preparation

Consult the standard precautions before intervention (see **D00**).

Products and utensils used for cleaning

- Clean absorbent material (cloth or paper)
- Fine abrasive cloth or pad (000)
- Alcohol
- Standard water
- Grinding stone
- Metal baskets
- Scraper or knife
- Air spray gun

During the disassembly, clean the parts roughly using paper wipes and check the appearance of the parts.

Sorting the parts during disassembly

Constitute two batches of parts::

- those which are highly oxidated or with significant marks (deep scratches or other defects).
- those which do not require any surface reconditioning operation.

All the seals and bearings disassembled should be discarded. These components are included in the maintenance kits.

Preliminary cleaning of oxidated parts

Immerse the highly oxidated parts in a bath of solvent for a few hours while checking the reaction of the product occasionally.

Refer to the procedures in force in your company in accordance with the local legislation.

After the treatment, rinse all the parts in large quantities of water and dry them with compressed air.

Part preparation for reassembly

Sand all the functional surfaces and the seal grooves with an abrasive pad.

All the flat surfaces should be honed and blown using compressed air.

Final cleaning

Immerse the parts in a bath of solvent. Dry them in compressed air.

When reassembling the components, remove traces of fingerprints or grease using alcohol or paper wipes.



Pump draining

In case of a pump transfer to another plant/site, it is necessary to drain the pump housings. In the other case (when the pump is returned for repair) do not drain the pump.

Study the safety instructions for pump relocation before disconnecting the pump (see **D00**).

⚠ DANGER

Certain gases become corrosive and toxic when trapped in oil. Always wear protective gloves when handling used and dirty pump oil, drain into a closable container, and do not breath the oil fumes. Always use fully self-contained breathing apparatus.

⚠ CAUTION

Always dispose of used or dirty oil, or sub-products properly and in compliance with all local, state and federal environmental laws and regulations.

Housing oil draining

Unfasten the fill plugs (1) in order to eliminate any excess pressure in the housings.

10 Remove the drain plugs (2) and allow the used oil to flow into a container (capacity: 1.5 l).

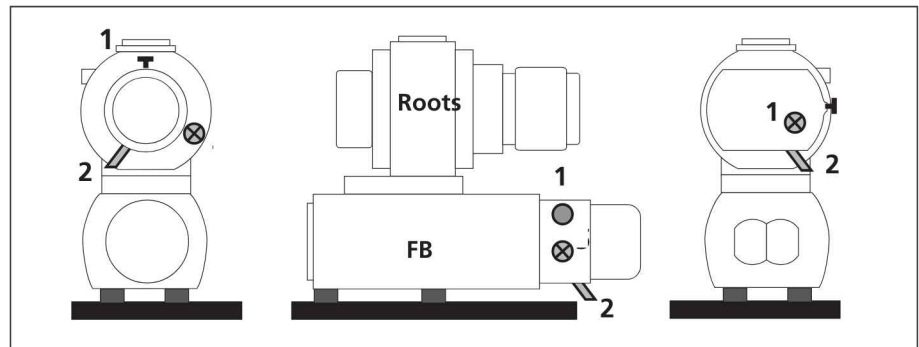

Replace the drain plugs (2) and their seals. Screw the fill plugs (1)

Caution: the Roots is equipped with two housings. Repeat the operation for each housing.

If the pump must be stored, study the storage conditions defined in **B10**.

Housing oil filling

See section *Filling the machine oil housings* **B 25**



Replacing the LP bearings

Study the safety precautions before intervention (see **D00** and **E11**).

Tools Recommended standard tools **F 40**

The pump bearings (low pressure side) are fitted with greased ceramic-ball bearings. The fluorinated grease is resistant to high temperatures and corrosion resulting from vacuum applications. However, the bearings do need to be replaced at maintenance intervals.

Maintenance frequency **D 10**

LP support components (ACP 120 standard) **F 125**

Partial maintenance kit Replace all components (bearings, Borelly washers, washers, O-rings) during this operation.

Minor maintenance kit **F 10**

Dismantling

Removing of cover

Remove the lifting ring (motor side).

6 Remove the four M8 x 20 Chc screws of the cover.

Remove the four washers.

Remove the cover.

Removing of bearings

3 Remove the end cap **(2)**.

Extract the O-ring **(3)**.

5 Remove the two LP bearing covers **(7)** and **(41)** from the LP support **(13)**.

Extract the O-rings **(8)**, Borelly washers **(9)** and washers **(10)**.

6 **21** Use an open box wrench to block the driving shaft in order to loosen screws **(4)** and **(40)**.

Recover the driving nut **(5)**, the two screws **(4** and **40)**, the two needles **(6)** and the washer **(39)**.

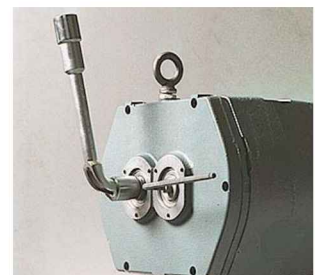



Replacing the LP bearings

Removing of bearings (cont'd)

 Insert a thin screwdriver in the front shield of the bearings in order to remove them.



 Remove the excess grease on the balls and push in their ball races using a screwdriver.



Insert the two ends of the bearing extractor between the balls. Turn its two fittings a quarter turn to lock them into the ball bearing.



FB standard version:

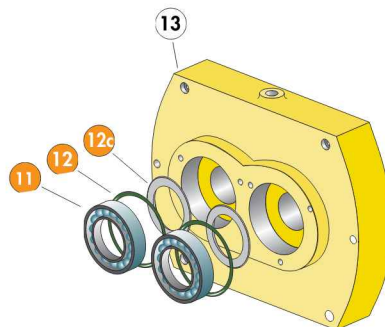

Remove the bearings (11) and the two O-rings (12).

Remove the spacer (12c).

FB "G" version:

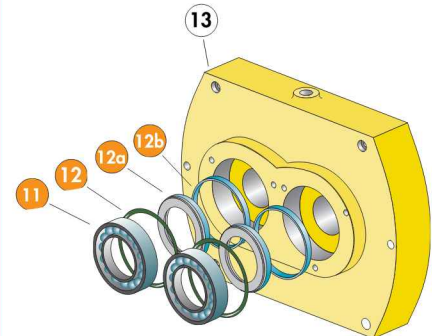

Remove the bearings (11) and the two O-rings (12).

Remove the lip seals (12a).

If the friction rings (12b) are deeply scared, remove them (Heat them to release)



Replacing the LP bearings

Refitting

Refitting the ball bearings

Stretch the O-rings (**12**), lubricate them with special grease obtained in the maintenance kit (see **F 10**) before fitting them the bearing housing of the LP support.

Lightly grease the bearing housings of the low pressure support and the outer ball race of each bearing.

FB standard version:

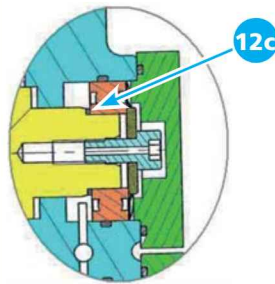

Position the two spacers (**12c**).

FB "G" version:



Place the lip seal (**12a**) in the positioner.

Place the positioner against the friction ring (**12b**).

Slide the push rod and push it to insert the seal into the friction ring (**12b**).

Position the two bearings (**11**) in their housing (marked side facing operator) then push **them** home, taking care not to shear the O-rings. This operation should be done manually and should not require any effort.

5 Temporarily clamp the bearings with the covers (**7**) and (**41**) and tighten them with six screws (**42**) to hold them.

Retaining the bearings

Fit the two pins (**6**) on the Driving shaft.



Position the Driving nut (**5**). Place a drop of Loctite 222e glue (see **F20**) on the drilled Chc M8 x 17 screw (**4**).

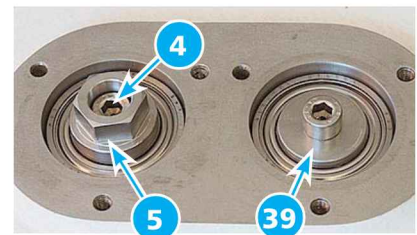

6 **21** Use an open-socket wrench to hold the driving shaft in place and enable the screw (**4**) to be tightened. Apply a clamping torque of **15 N·m**. Repeat the same operation for the screw (**40**) on the driven shaft with the washer (**39**).



Replacing the LP bearings

Removing the axial play on the stopped shafts

Fit the protection washers (10) on the bearings.

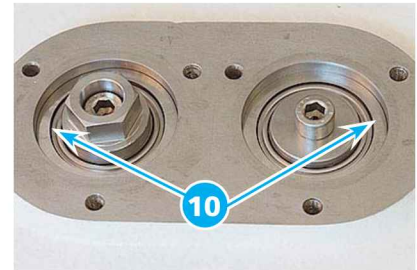

Fit the Borelly washers (9) (two washers per shaft).

Lightly grease the two O-rings (8) and fit them in the grooves on the two LP bearing covers (7) and (41).

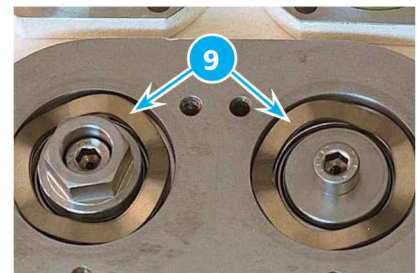

5 Fix the two covers with six Chc M6 x 16 screws (42), clamping torque of **15 N·m**.

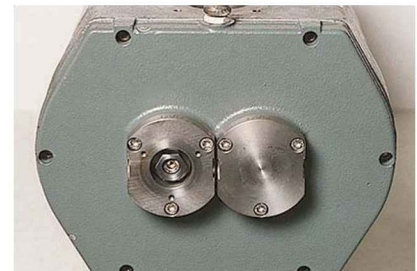

Refitting the cover (Driving shaft)

21 Check correct operation by turning the driving shaft with a wrench.

There should be no tight spots.

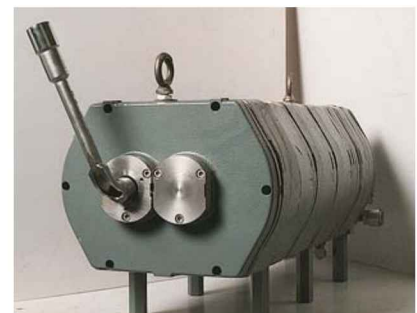

Lightly grease the end cap O-ring (3) and place it in its groove.

3 Refit the end cap (2) with three Chc M4 x 10 screws (1), clamping torque of **2 N·m**.





Replacing the LP bearings

Refitting the cover Fit the cover.

6 Fix the cover with 4 Chc M8 x 20 screws equipped with flat washers.

Screw the lifting ring (motor side).

Helium test We recommend to carry out an helium test after intervention on the LP bearings..

Helium test **E 1030**



Freeing up the ACP 120

Study the safety precautions before intervention (see **D00** and **E11**).

Recommended standard tools **F 40**

If, after a prolonged stop, the ACP 120 pump does not restart due to deposition of process by-product, it may be possible to free it up manually.

6 Remove the four M8 x 20 Chc screws of the cover.

Remove the four washers.

Remove the cover.

3 **21** Remove the protective cover (**1**) and remove the O-ring by removing the three M4 x 10 Chc screws to get access to the Driving shaft.

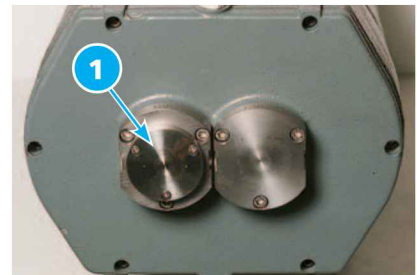

Using the box wrench, move the driving shaft in both directions of rotation until free rotation is obtained.

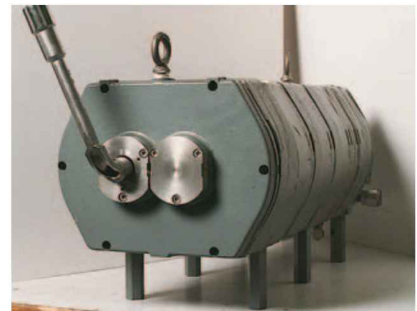

Clean the O-ring and grease it lightly with vacuum grease.

Reinstall the O-ring and the protective cover.

Restart the pump.

CAUTION

Using excessive force to rotate pump may damage the pump.



Helium test

Preliminary operation

Drain the gear box casing and keep oil apart.

Pump draining..... **E 50**

Leak tightness checking

Helium spray measurement condition:

- Connect the functional block to the leak detector.
- Pumping inside the functional block and measure the residual helium rate.

Residual helium rate $\leq 1 \cdot 10^{-7}$ hPa l/s

- Spray the outside of the functional block with helium and check the helium rate.

Helium rate $\leq 1 \cdot 10^{-6}$ hPa l/s

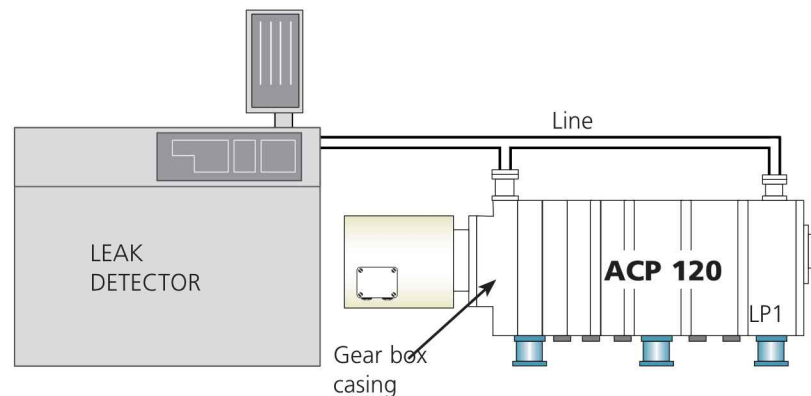

Filling the machine oil housing

Fill the oil gear box casing with kept apart oil.

Filling the machine oil housings **B 25**



Exhaust pipe maintenance

Study the safety precautions before intervention (see **D00** and **E 11**).



When the exhaust is maintained, avoid any contact with the reaction by-products (deposit, powder...) strongly corrosive: wear gloves and a breathing mask. We recommend to ventilate the premises well and disassemble the equipment under a ventilated hood.

Tools Recommended standard tools **F 40**

Maintenance frequency The maintenance frequency of the silencer of the pump depends on the process used.

Maintenance frequency **D 10**

Exhaust pipe components **F 250**

Dismantling

Removing of cover Remove the lifting ring (motor side).

6 Remove the four M8 x 20 Chc screws of the cover.

Remove the four washers.

Remove the cover.

Exhaust disassembly **6** Unscrew and remove the 2 H M8 screws (**7**).

Remove the washers (**6**).

Screw the lifting rings on the pump body.

Sling the pump.

17 **21** Unscrew and remove the 6 HM10 maintaining screw (pump on frame).

Remove the washers.

With a lifting system, lift the functional block taking care not to damage the pipes.

Remove the silencer sub-assembly.



Exhaust pipe maintenance

Silencer disassembly

5 Unscrew and remove the 4 Chc M6 screws (**15**) and remove the 4 washers (**14**).

Remove the baffle plate (**13**).

Remove and discard the 2 O-rings (**11** and **12**).

13 Unscrew and remove the 2 H M8 nuts (**5**) and remove the 2 washers (**4**).

Remove the exhaust elbow (**2**).

Remove and discard the 3 O-rings (**1**, **8** and **9**).

Anti suckback valve disassembly

5 Unscrew and remove the 4ChcM6 exhaust pipe (**21**) fixing screws (**23**) and remove the 4 washers (**22**).

Remove the exhaust pipe (**21**).

Remove the anti suckback valve (**17**) and the spring (**18**).

Remove and discard the O-rings (**16**, **19** and **20**).

Part cleaning

Clean the metal parts in a bath of hot water using a cloth if necessary.

Dry in the air or with compressed air.

Reassembly

Exhaust pipe components **F 250**

The O-rings to be replaced are included in the exhaust pipe maintenance kit.

Minor maintenance kit **F 10**

Anti-suckback valve reassembly

Refit the new O-ring (**16**) on the anti-suckback valve (**17**).

Grease new O-rings (**19** and **20**) with vacuum grease and refit them on the exhaust pipe (**21**).

Refit the anti-suckback valve (**17**) on the spring (**18**) and the spring on the exhaust pipe (**21**) (spring axe and exhaust pipe axe aligned).

5 Refit the exhaust pipe (**21**) on the baffle plate (**13**) and secure it with the 4 Chc M6 screws (**23**) equipped with washer (**22**).



Exhaust pipe maintenance

Silencer reassembly

Grease 3 new O-rings (**1**, **8** and **9**) with vacuum grease and refit them on the exhaust elbow (**2**).

Refit the exhaust elbow (**2**) on the silencer cylinder (**10**).

 Secure it with the 2 nuts (**5**) equipped with washer (**4**).

Grease 2 new O-rings (**11** and **12**) with vacuum grease and refit them on the baffle plate (**13**).

Refit the baffle plate (**13**) on the silencer cylinder (**10**).

 Secure it with the 4 Chc M6 screws (**15**) equipped with washer (**14**).



Exhaust reassembly

The functional block is lifted with lifting system.

Refit the silencer sub-assembly.

 Secure it with the 2 H M8 screws (**7**) equipped with washers (**6**).

Place the functional block on the frame.

  Screw the 6 H M10 fixing screws equipped with washers maintaining the pump on the frame.

Unscrew and remove the lifting rings.

Cover reassembly

Place the cover.

 Secure it with the 4 Chc M8 screws equipped with washer.

Screw the motor side lifting ring.

Helium test

We recommend to carry out an helium test after intervention on the exhaust pipe.

Helium test 



Maintenance components

Operating instructions – ACP 120 / ACG 600

F 000 *Spare parts - Instruction for use*

F 010 *Minor maintenance kit*

F 030 *Ingredients et consommables*

F 040 *Recommended standard tools*

F 125 *LP support components*

F 250 *Exhaust pipe components*

Spare parts - Instructions of use

Replacement of parts and use of non genuine parts

Our products are designed to comply with current EC regulations and guarantee optimal operating conditions with maximum safety conditions for the user.

Any modification of the product made by the user is liable to lead to non-compliance with the regulations, or even to put into doubt the performance of the product and the user's safety.

Replacement of defective components with parts that are not genuine, jeopardizes the initial safety conditions of the equipment.

In such cases, the EC declaration of conformity becomes null: The manufacturer withdraws responsibility for such operations.

Besides, counterfeiting and unfair trading of parts are condemned under civil and criminal laws.

The manufacturer urges the user not to use «imitation parts», or the misappropriation and pirating of intellectual property performed by some dishonest operators.

The manufacturer supplies maintenance components, spare parts or kits to perform the maintenance of its products (see **F**).

Minor maintenance kit

Maintenance kit for functional block

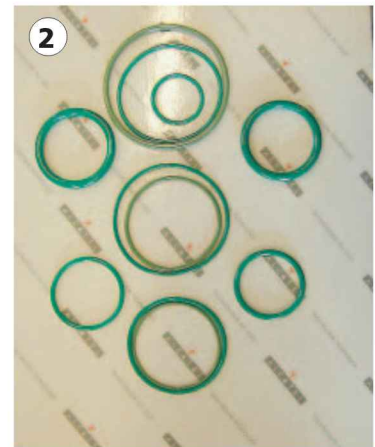

Item	Description	P/N
1, 2	LP bearings maintenance kit, FB standard version	110907
1, 2	LP bearings maintenance kit, FB "G" version	110909
2	Exhaust maintenance kit	106624

Ingredients and consumables

Description











Item	Description	Qty	P/N
3	Light threadlock glue Loctite 222e		
4	LP bearing grease	1	Bearing maintenance kit (F 10)
5	Vacuum grease		064628
6	Oil Fomblin* 2.5l	2.5 l	064659
7	Oil Fomblin* 0.5l	0.5 l	064657

* Registered trade mark MONTEDISON

Recommended standard tools

Basic tools

- Flat spanners 13, 17, 21 mm   
- Allen keys 6 pans 3, 5, 6 and 10 mm    
- Flat screwdrivers 0.6 x 3.5 mm 
- Angled open-socket wrench of 21 mm 
- Grindstone or fine abrasive cloth
- Outside puller for ball bearings, P/N 102084
- Seal extractor, P/N 063285
- Lip seal positionner, P/N 104070
- Funnel and its flexible tube, P/N 107381

Workshop tools

- Lifting bridge, minimum load 300 kg
- Dry compressed air
- Clean roll of cloth
- Plastic mallet
- Cleaning products

LP support components

FB standard version

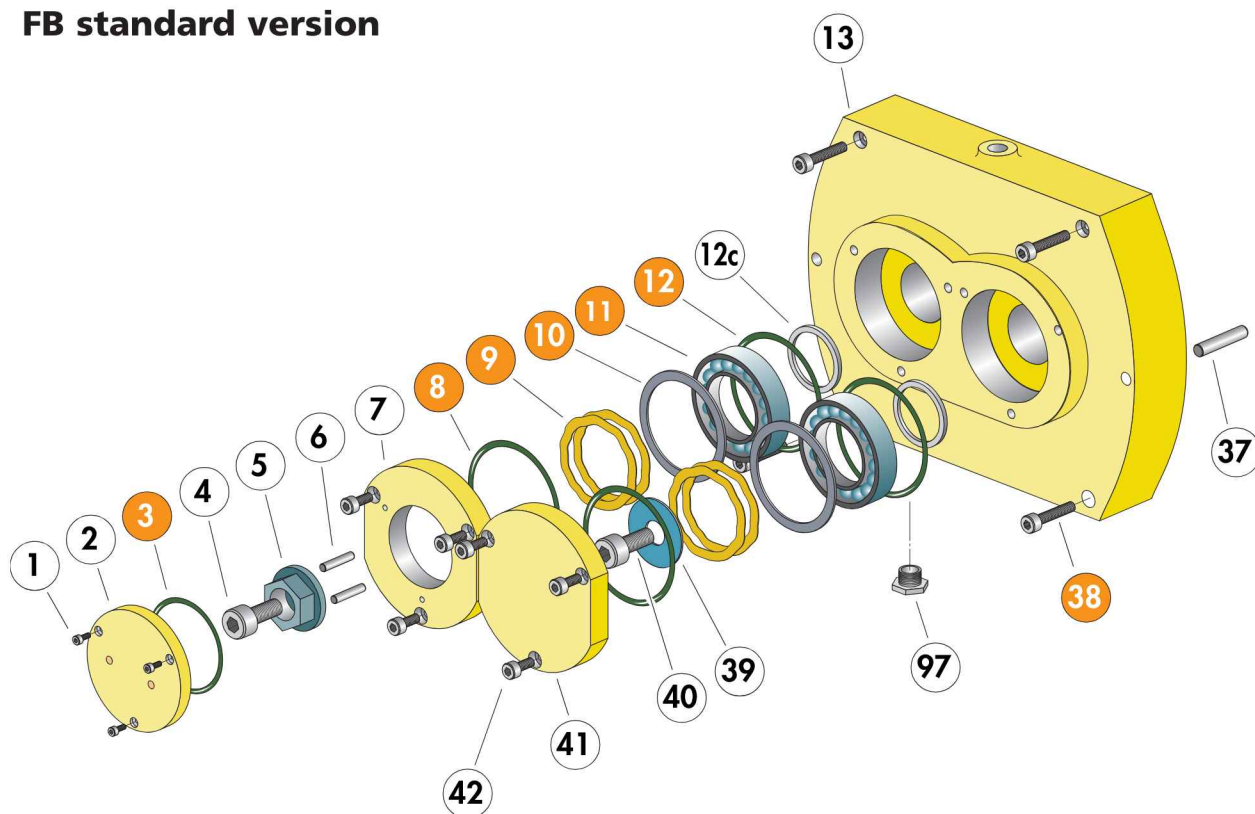

Item	Description	Qty*	P/N
1	Screw Chc M4-10	3/3	-
2	End cap	1/1	-
3	O-Ring c 2.00 d 35.00	1/1	Maint. kit
4	Screw Chc M8-17	1/2	-
5	Driving nut	1/1	-
6	Needle Ø4-15.8	2/3	-
7	LP Bearing cover	1/1	-
8	O-ring c 2.50 d 52.00	2/2	Maint. kit
9	Borrelly washer	4/4	Maint. kit
10	Washer	2/2	Maint. kit
11	Ball bearing	2/2	Maint. kit

Item	Description	Qty*	P/N
12	O-Ring c 2.50 d 45.00	2/2	Maint. kit
12c	Spacer	2/2	-
13	LP support	1/1	-
37	Centering Pin Ø8-30	2/10	-
38	Screw Chc M6-20	4/40	-
39	Washer	1/1	-
40	Idem 4	1/2	-
41	LP bearing cover	1/1	-
42	Screw Chc M6-16	6/6	-
97	Male plug	1/5	-

* Quantity / Total quantity

LP support components

FB "G" version

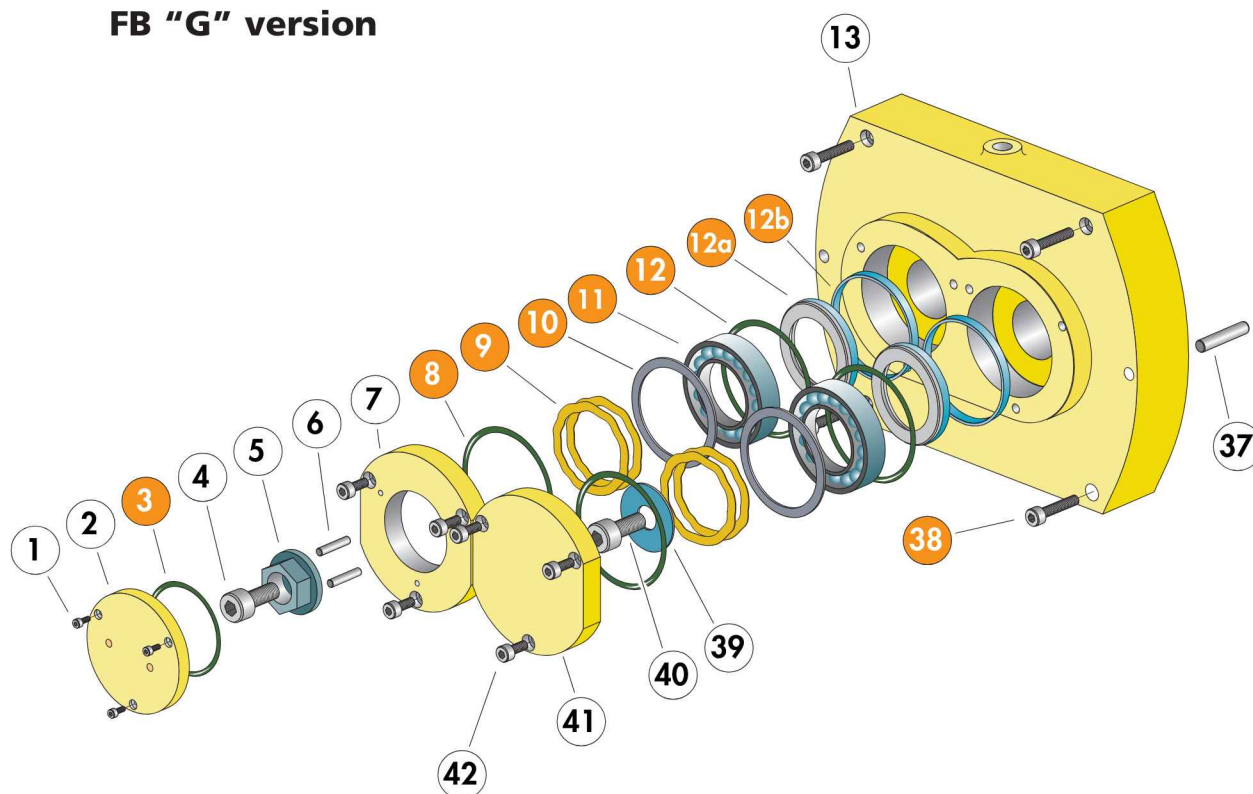

Item	Description	Qty*	P/N
1	Screw Chc M4-10	3/3	-
2	End cap	1/1	-
3	O-Ring c 2.00 d 35.00	1/1	Maint. kit
4	Screw Chc M8-17	1/2	-
5	Driving nut	1/1	-
6	Needle Ø4-15.8	2/3	-
7	LP Bearing cover	1/1	-
8	O-ring c 2.50 d 52.00	2/2	Maint. kit
9	Borrelly washer	4/4	Maint. kit
10	Washer	2/2	Maint. kit
11	Ball bearing	2/2	Maint. kit

Item	Description	Qty*	P/N
12	O-Ring c 2.50 d 45.00	2/2	Maint. kit
12a	Lip seal	2/2	Maint. kit
12b	Friction ring	2/2	Maint. kit
13	LP support	1/1	-
37	Centering Pin Ø8-30	2/10	-
38	Screw Chc M6-20	4/40	-
39	Washer	1/1	-
40	Idem 4	1/2	-
41	LP bearing cover	1/1	-
42	Screw Chc M6-16	6/6	-
97	Male plug	1/5	-

* Quantity / Total quantity

Exhaust pipe components

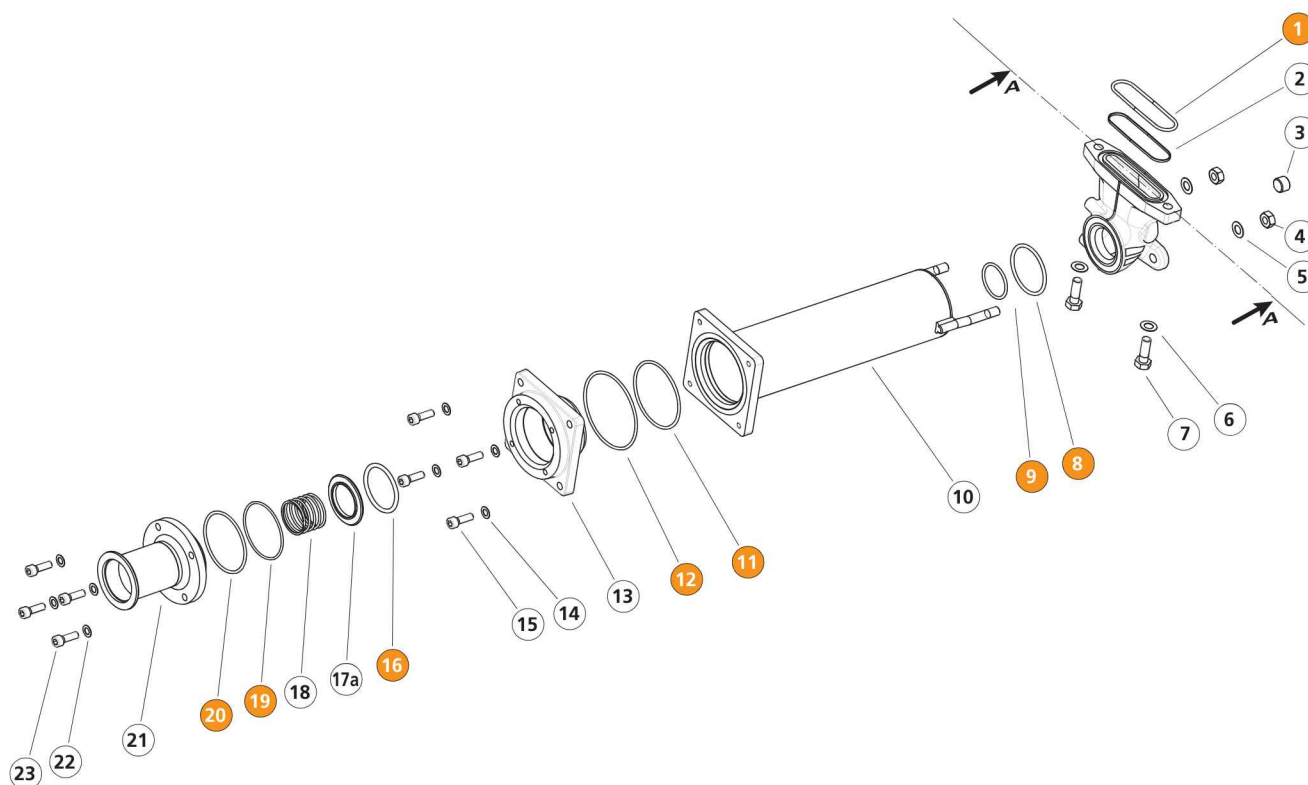

Rep.	Description	Qty*	P/N
1	O-ring c 2.62 d 56.82	1/1	Maint. kit
2	Exhaust elbow	1/1	-
3	Plug	1/1	-
4	Nut H M8 5.8	2/2	-
5	Washer Onduflex Ø8	2/4	-
6	Idem 5	2/4	-
7	Screw H M8-25 6.8	2/2	-
8	O-ring c 2.50 d 29.00 FEP	1/1	Maint. kit
9	O-ring c 3.00 d 41.00	1/1	Maint. kit
10	Silencer cylinder	1/1	-
11	O-ring c 2.50 d 59.00 FEP	1/1	Maint. kit
12	O-ring c 2.50 d 66.00	1/1	Maint. kit

Rep.	Description	Qty*	P/N
13	Baffle plate	1/1	A214750S
14	Washer Onduflex Ø6	4/8	-
15	Screw Chc M6-20 8.8	4/8	-
16	O-ring c 3.60 d 37.30		Maint. kit
17a	Anti-suckback valve	1/1	-
18	Spring	1/1	-
19	O-ring c 1.90 d 51.00 FEP	1/1	Maint. kit
20	O-ring c 2.50 d 54.00	1/1	Maint. kit
21	Horizontal exhaust pipe	1/1	-
22	Idem 14	4/8	-
23	Idem 15	4/8	-

* Quantity / Total quantity



Appendix

Operating instructions – ACP 120 / ACG 600

G 100 *Declaration of incorporation of partly completed machinery*

G 110 *Purposed electrical schematic*

G 200 *Service*

**DECLARATION OF INCORPORATION
OF PARTLY COMPLETED MACHINERY**

We, **adixen Vacuum Products**
98, avenue de Brogny · BP2069
74009 Annecy cedex – France

ISO 9001 CERTIFIED

declare under our sole responsibility that the following products:

ACP 120
ACP 120G
ACG 600
ACG 600G

to which this declaration relates are in conformity with the relevant provisions of the following European Directives:

2006/042/EC: Machinery directive (Annex II, no 1 A)
2006/095/EC: Low voltage directive
2004/108/EC: Electromagnetic Compatibility Directive
2002/095/EC: Restriction of Hazardous Substances

when used in accordance with the instruction manual of the product.
The relevant operating instructions are in compliance with appendix VII, part B.

Those products comply with the relevant provisions of the above Directives and carry the CE marking.

This partly completed machinery must not be put into operation until the machinery into which it is to be incorporated has been declared in conformity with the provisions of the 2006/042/EC Directive.

We, authorized representatives undertake to transmit, in response to a reasoned request by national authorities, relevant information on the partly completed machinery

Signatures:

Annecy, May 13, 2013

Authorized person to compile the relevant technical documentation:

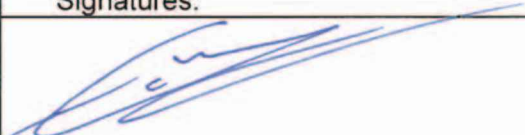
Mr. Eric TABERLET
President

Mr. Gilles BARET
Products and Technology Director
98, avenue de Brogny · BP 2069 / 74009 Annecy - France

Service

Pfeiffer Vacuum offers first-class customer service!

- On-Site maintenance for many products)
- Overhaul / repair in the nearby Service Location
- Fast replacement with refurbished exchange products in mint condition
- Advice on the most cost-efficient and quickest solution

Detailed information, addresses and forms at: www.pfeiffer-vacuum.com (Service).

Overhaul and repair in the Pfeiffer Vacuum Service Center

The following general recommendations will ensure a fast, smooth servicing process:

- ➔ Fill out the «Service Request/Product return» form and send it to your local Pfeiffer Vacuum Service contact.
- ➔ Include the confirmation on the service request from Pfeiffer Vacuum with your shipment.
- ➔ Fill out the declaration of contamination and include it in the shipment (mandatory!). The Declaration of contamination is valid for any product/ device including a part exposed to vacuum.
- ➔ Dismantle all accessories and keep them.
- ➔ Close all the ports flange openings by using the original protective covers or metallic airtight blank flanges for contaminated devices.
- ➔ If possible, send pump or unit in its original packaging.

Sending of contaminated pumps or devices

No devices will be accepted if they are contaminated with micro-biological, explosive or radioactive substances. "Hazardous substances" are substances and compounds in accordance with the hazardous goods regulations (current version).

- ➔ Neutralize the pump by flushing it with nitrogen or dry air.
- ➔ Close all openings airtight.
- ➔ Seal the pump or device in suitable protective film.
- ➔ Return the pump/device only in a suitable and sturdy transport container and send it in while following applicable transport conditions.

Pump or device returned without declaration of contamination form fully completed and/or non-secured in a suitable packaging, will be decontaminated and/or returned at the shipper's expense.

Exchange or repaired devices

The factory operating parameters are always preset with exchange or repaired devices. If you use specific parameters for your application, you have to set these again.

Service orders

All service orders are carried out exclusively according to our general terms and conditions for the repair and maintenance, available in our website.

**Vacuum Solutions
from a single Source**

Pfeiffer Vacuum stands for innovative and custom vacuum solutions worldwide, technological perfection, competent advice and reliable service.

**Complete range
of products**

From a single component to complex systems: We are the only supplier of vacuum technology that provides a complete product portfolio.

**Competence in
theory and practice**

Benefit from our know-how and our portfolio of training opportunities! We support you with your plant layout and provide first-class on-site service worldwide.

**Are you looking for a
perfect vacuum solution?
Please contact us:**

Pfeiffer Vacuum GmbH
Headquarters · Germany
T +49 6441 802-0
Info@pfeiffer-vacuum.de
www.pfeiffer-vacuum.com

adixen Vacuum Products
France
T +33 (0) 4 50 65 77 77
info@adixen.fr

