

Operating Instructions

TMH 520 / TMU 520
TMH 520 P / TMU 520 P

Turbomolecular Drag Pumps



FOR SALES AND SERVICE PLEASE CALL:

PTB SALES ☎ : 626.334.0500
service@ptbsales.com
www.ptbsales.com

DATE SERVICED: _____

VIEW OUR INVENTORY



INDEX

	Page		Page
1. Safety Precautions	3	4. Operations	9
1.1. For Your Orientation	3	4.1. Before Switching ON	9
1.2. Pictogram Definitions	3	4.2. Switching ON	9
2. Understanding The Pumps		4.3. Heating (Only Pumps With Heating Sleeves)	9
TMH 520 / TMU 520	4	4.4. Switching OFF And Venting	9
2.1. Main Features	4	4.5. Shutting Down For Longer Periods	9
2.2. Differences Between The Pump Types	4	5. What To Do In Case	
3. Installation	5	Of Breakdowns ?	10
3.1. Preparations For Installation	5	6. Maintenance	11
3.2. Assembling The Pump,		6.1. Changing The Lubricant Reservoir	11
Connecting The High Vacuum Side.....	5	7. Service	12
Fitting The Splinter Shield	6	8. Technical Data	13
3.3. Connecting The Fore-Vacuum Side	6	8.1. Dimensions	13
3.4. Connecting The Cooling Unit.....	7	9. Accessories	14
Cooling Water From The Mains	7	10. Spare Parts	15
Cooling With The Recycled		Declaration Of Contamination	17
Water Cooling Unit TZK (Accessory)	7	Manufacturer's Declaration	(last page)
Air Cooling (Accessory)	7		
3.5. Connecting The Venting Valves	8		
3.6. Connecting The Electronic Drive Unit.....	8		
3.7. Connecting The Sealing Gas Valve	8		

1. Safety Precautions

- ☞ Read and follow all the instructions in this manual.
- ☞ Inform yourself regarding:
 - Hazards which can be caused by the pump;
 - Hazards which can arise in your system;
 - Hazards which can be caused by the medium being pumped.
- ☞ Avoid exposing any part of your body to vacuum.
- ☞ Comply with all safety and accident prevention regulations.
- ☞ Check regularly that all safety requirements are being complied with.
- ☞ Do not operate the pump with open high vacuum flange.
- ☞ Do not carry out any unauthorised conversions or modifications on the pump.
- ☞ When returning the pump to us please note the shipping instructions.
- ☞ Use at least four bracket screws to connect the high vacuum flange.
- ☞ Fix down the pump in accordance with the instructions on installation.
- ☞ Do not disconnect the pump cable during operations.
- ☞ When the pump is open, disconnect the electronic drive unit from the mains.
- ☞ If a heater is in use temperatures of up to 120 °C can be present in the area of the high vacuum flange. Take care to avoid burns !
- ☞ During operations, temperatures of up to 65 °C can arise in the lower part of the turbopump. Take care to avoid burns!
- ☞ Keep leads and cables well away from hot surfaces (> 70 °C).
- ☞ After switching off the pump, disconnect the electronic drive unit only once the rotor is at rest.
- ☞ When working on the pump, only open the high vacuum flange once the rotor is at rest.
- ☞ When using sealing gas, limit the pressure in the hose connection to 2 bar via the overflow valve.

Modifications reserved.

1.1. For Your Orientation

Instruction in the text

➔ Working instruction: Here, you have to do something.

Symbols used

The following symbols are used throughout in the illustrations:

- Ⓜ High vacuum flange
- Ⓥ Fore-vacuum flange
- Ⓧ Flutanschluß
- Ⓝ Venting connection
- Ⓚ Air cooling
- Ⓛ Power connection
- Ⓞ Sealing gas connection

Position numbers

Identical pump and accessory parts have the same position numbers in all illustrations.

1.2. Pictogram Definitions



Danger of burns from touching hot parts.



Danger of an electric shock.



Danger of personal injury.



Danger of damage to the pump or system.



Danger of injury from rotating parts.

2. Understanding The Pumps TMH 520 / TMU 520

2.1. Main Features

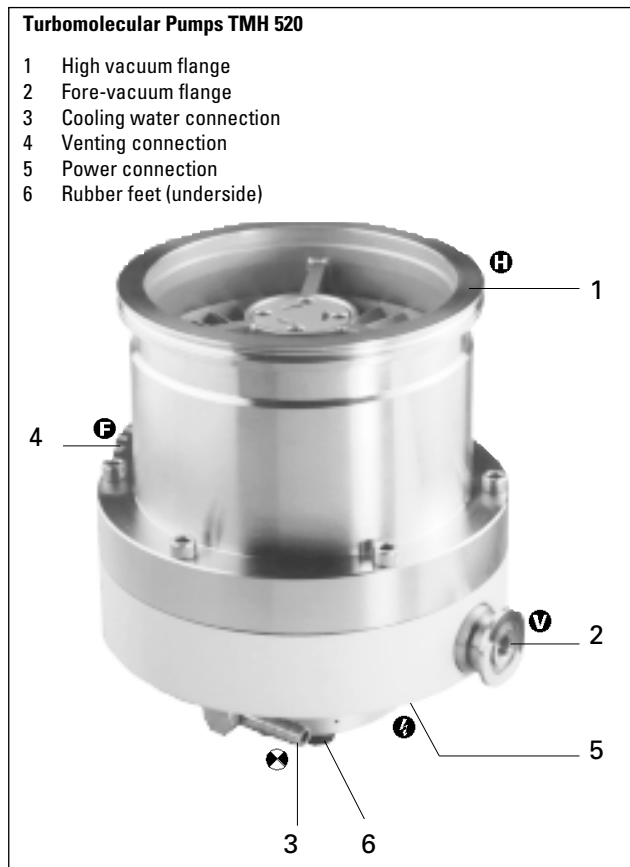

Cooling

Standard: Water cooling.
 Alternative: Air cooling as an accessory.
 Integrated excess temperature safety feature:
 Electronic drive unit reduces rotor rotation speed to zero.

Bearings

High vacuum side: Wear free permanent magnetic bearing.
 Fore-vacuum side: Oil circulatory lubricated bearings with ceramic balls.

Pumps for sealing gas operations

The pump types TMH 520 P and TMU 520 P (see the rating plate) are designed for connection of an inert sealing gas. The connection is described in Section 3.7.

Proper use

- The Turbomolecular Pumps TMH 520 / TMU 520 may only be used for the purpose of generating vacuum.
- The turbopumps may only be used to pump those media against which they are chemically resistant. For other media the operator is required to qualify the pumps for the processes involved.
- If the process produces dust, the maintenance intervals must be specified accordingly and sealing gas must be used (only for version "P").
- The Turbomolecular Pumps TMH 520 / TMU 520 may only be operated with a PFEIFFER Electronic Drive Unit and relevant cables.
- The turbopump must be connected to a backing pump as per Section 3.3..

Improper use

Certain types of use are regarded as improper, e.g.:

- Pumping corrosive or explosive gases.
- Operating the pump where explosive processes are involved.
- The pumping of gases and vapours which attack the materials of the pumps.
- The pumping of corrosive gases without sealing gas.
- The pumping of condensating vapours.
- Operations involving impermissibly high levels of gas loads.
- Operations with impermissibly high fore-vacuum pressure.
- Operations with improper gas modes.
- Operations involving too high levels of heat radiation power (see Section 8. "Technical Data").
- Using accessories not named in this manual and/or not authorised by the manufacturer.

Improper use will cause any rights regarding liability and guarantees to be forfeited.

2.2. Differences Between The Pump Types

Feature	TMH 520	TMU 520
HV-flange	ISO-K	CF-F
HV seal	Viton	Metal
Attainable final pressure	< 1 · 10 ⁻⁸ mbar (without baking out)	< 5 · 10 ⁻¹¹ mbar (with baking out)

Abbreviations on the rating plate of the pump

Suffix "P": Pumps with the designation TMH/TMU 260 P have been designed for the connection of purge gas (see Section 3.7.).

3. Installation

3.1. Preparations For Installation



Do not carry out any unauthorised conversions or modifications on the pump.

- The maximum permissible rotor temperature of the pump is 90 °C. If the vacuum chamber or parts in the vacuum chamber are heated must be fitted if necessary, suitable shielding in the vacuum chamber before the turbopump (constructional suggestions available on request).
- Only remove blank flanges on the high and fore-vacuum side just before connecting.
- TMH 520/TMU 520 turbopumps are supplied with lubricant reservoirs fitted and filled.
- Appropriate shielding must be provided (available on request) if magnetic fields >5,0 mT are involved.
- If the pump is baked out, the heating sleeve and the body of the pump must be insulated to prevent burning.
- In the event of a sudden standstill of the rotor, torques of up to 2550 Nm can arise and these must be taken up by the turbopump and frame. Pumps must be anchored as follows:
 - ISO flange with 4 bracket screws,
 - or
 - CF flange with the complete set of M8 screws,
 - or
 - Underside of the pump with 4 screws M5, screws quality 8.8.

3.2. Assembling The Pump, Connecting The High Vacuum Side

Important:

Maintain the utmost cleanliness when fitting all high vacuum parts. Unclean components prolong the pumping time.

Use of the splinter shield

A splinter shield in the high vacuum flange protects the turbopump against foreign particles emanating from the vacuum chamber but it does reduce the pumping speed of the pump by approx. 15%.

For fitting please refer to "Fitting The Splinter Shield".

The high vacuum side can be flanged directly to the vacuum chamber or via a bellows or a vibration compensator (please see "Accessories").

Connecting via a bellows

If the high vacuum side is to be flanged via a bellows, the turbopump must be secured for example via the holes on the underside of the turbopump must be secured for example via the holes on the underside of the pump. The fastening must be able to withstand the torque referred to in Section 3.1.

Connecting via a vibration compensator



The maximum permissible temperature at the vibration compensator is 100 °C.

Where a vibration compensator is in use, a freely suspended turbopump can be flanged onto the vacuum chamber. Additional fastening is unnecessary.

Directly flanging the pump

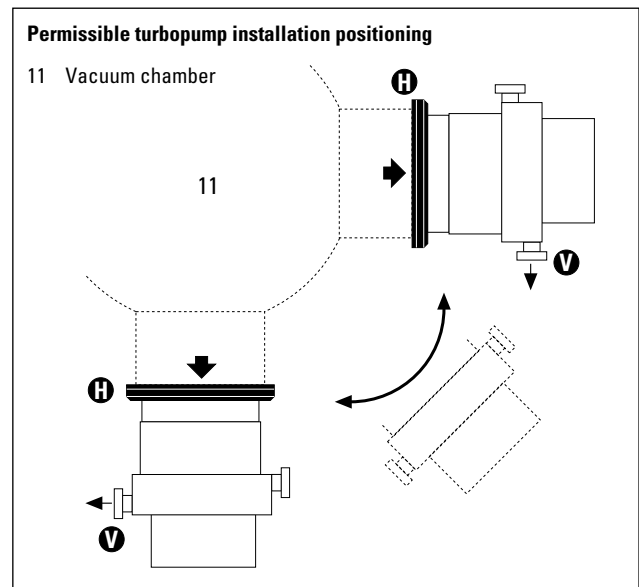

Maximum high vacuum flange axial loading capacity 1000 N (corresponds to 100 kg). No asymmetrical loading on the high vacuum flange.

With horizontal pump installation and oil-sealed backing pump (e.g. rotary vane pumps) the fore-vacuum flange of the turbopump must be aligned vertically downwards (deviation max. $\pm 20^\circ$), otherwise the turbopump could become dirty.

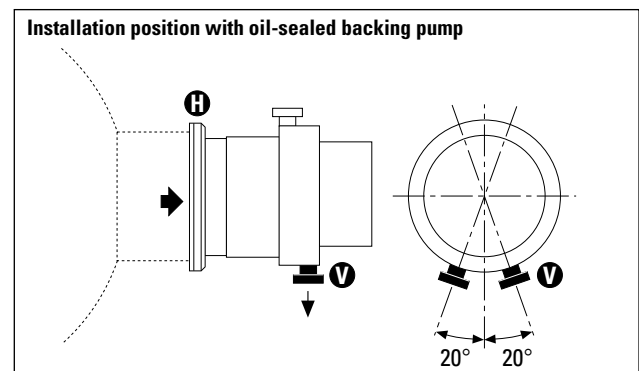

No forces must be transmitted from the pipe system to a pump which is anchored. Support or suspend all piping leading to the pump.

Fitting The Splinter Shield

Highvacuum flanges DN 100 and DN 160

Insert the splinter shield in the high vacuum flange so that the curvature of the grill faces outwards.

- ➔ Bend clamping lugs slightly outwards so that the splinter shield will sit firmly in the high vacuum flange (preventing noise).
- ➔ Insert splinter shield in the high vacuum flange with clamping lugs bent slightly inwards.
- ➔ Press splinter shield outer ring into the high vacuum flange up to the stop limit.

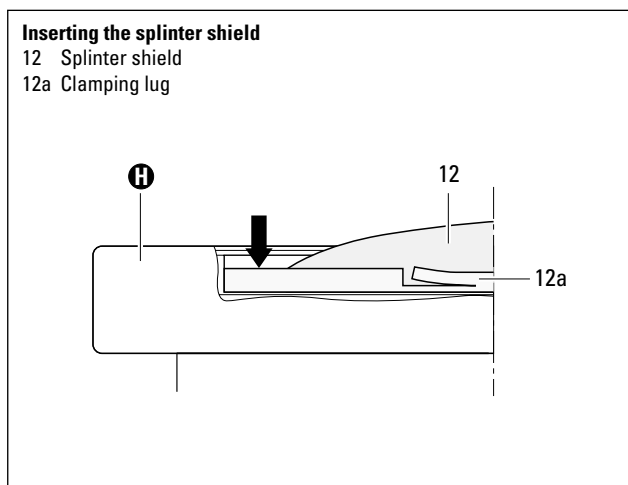

3.3. Connecting The Fore-Vacuum Side

Backing pump: Vacuum pressure ≤ 5 mbar
 Recommended backing pump: Oil free Diaphragm Pump or rotary vane pump from the PFEIFFER product range (note installation position of the turbopump, see Section 3.2.).

Connecting the backing pump

All fore-vacuum line connections: With normal small flange components or screwed hose connections..



Exhaust gases from the backing pump must be conducted away. Ensure the full width of the fore-vacuum flange remains unhindered by other components.



The exhausted process gases and vapours can represent a health hazard and can also be environmentally damaging. Comply with all gas manufacture's safety instructions.

- ➔ Fit the vacuum safety valve in the fore-vacuum line (in PFEIFFER rotary vane vacuum pumps already integrated). This prevents vacuum chamber venting via the backing pump.
- ➔ With rigid pipe connections: Fit bellows in the connecting line to reduce vibration.
- ➔ Backing pump power connection: see operating instructions for the electronic drive unit.

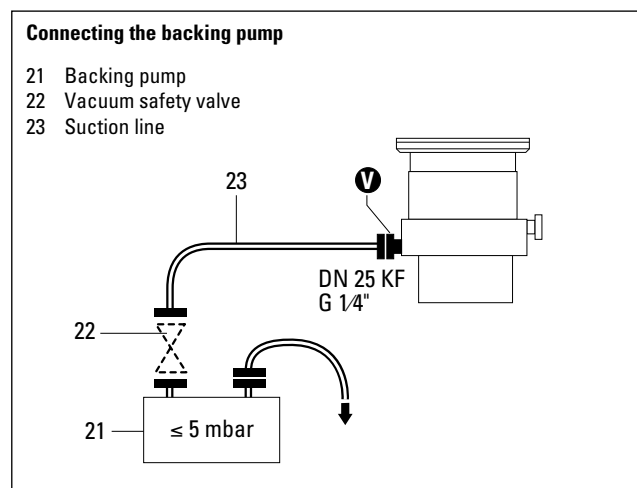

3.4. Connecting The Cooling Unit

The turbopumps are water cooled as standard.

Cooling water either

- From the mains or
- From Recycled Water Cooling Unit TZK with closed circuit.

As an accessory: Air cooling (with an ambient temperature of <35 °C).

Cooling Water From The Mains

Cooling water must be filtered to prevent deposits forming in the pump.

Minimum cooling water requirements:

Mechanically clean, optically clear, no turbidity, no sediment, chemically neutral and temperature > dew point.

Minimum oxygen content	max.	4	mg/kg
Maximum chloride content	max.	100	mg/kg
Maximum carbonate hardness:	max.	10	° dH
Maximum consumption of: potassium permanganate:	max.	10	mg/kg
Carbon dioxide		absent	
Ammonia:		absent	
pH-value:		7 – 9	
Max. fore-line over pressure:	max.	6	bar
Minimum flow rate at max. gas throughput:		50	l/h at 15 °C

Connecting to the water mains

- ➔ Fit dirt trap (accessory) in the fore-line.
- ➔ Using circlips, connect fore-line to one of the two cooling water connections.
- ➔ Connect Cooling Water Monitor TCW 002 (accessory) in the return line.
- ➔ Connect return line to the other cooling water connection of the turbopump.
- ➔ Tighten all circlips and ensure hose lines are seated firmly.
- ➔ Tighten the hollow screws on the cooling water connection to a torque of 20 Nm.

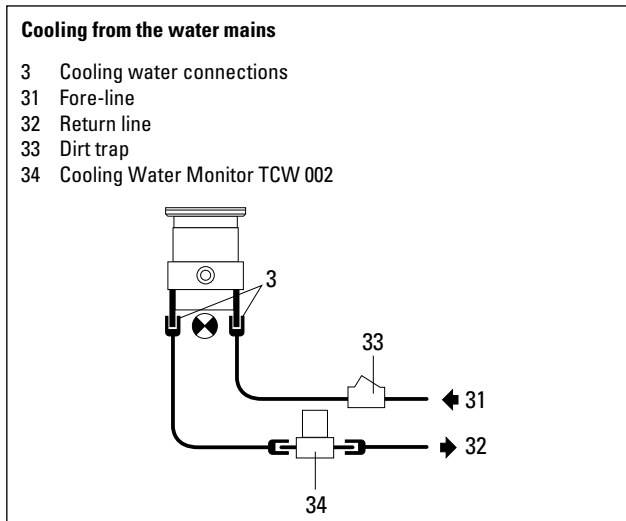

Cooling With The Recycled Water Cooling Unit TZK (Accessory)

Connecting to the TZK

A dirt trap in the fore-line is not permissible.

All other steps: As for connection to the water mains.

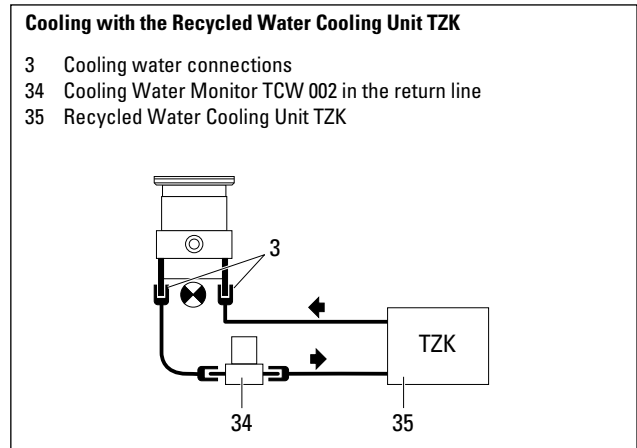

Air Cooling (Accessory)



Air cooling only if ambient temperature < 35 °C.

Ensure adequate air circulation and ventilation.

Fitting the air cooling

- ➔ Place turbopump (blank flanged to prevent damage to the sealed surface) on its high vacuum flange.
- ➔ Unscrew rubber feet from the base of the pump. The fan must be parallel to the axis fore-vacuum connection - venting connection (see illustration below).
- ➔ Screw air cooling to holder with 4xM5 screws and spring washers onto the turbopump.

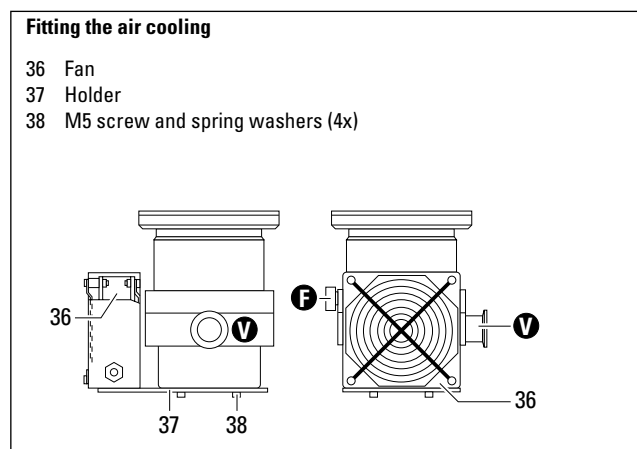

Power connection, air cooling

Please see the operating instructions, Electronic Drive Unit TCP 380 or TCP 600.

3.5. Connecting The Venting Valves

- Manual venting to atmospheric pressure:
With standard venting screw in the venting connection (without additional venting valve).
- Automatic venting on switching off and power failure:
Fitting a venting valve (accessory).

Venting Valve	Control Unit	Electronic Drive Unit	Venting Procedure After Switching Off Or Power Failure
TSF 010	not required	Independent	Immediate; Venting valve remains open
TSF 012	not required	TCP 380/600	Delayed (venting begins at approx. 20% of the rated rotation speed); venting valve; remains open
TVF 012	TCF/TCV 103	TCP 380/600	Delayed; adjustable (with TCS 304)

Fitting the venting valves

See the operating instructions for the respective unit. Where flange size DN 10-KF is involved, use Adapter PM 033 737-T.

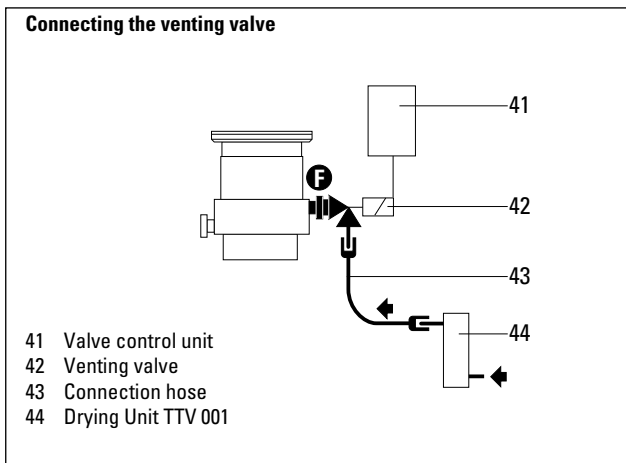

Power connections

See the operating instructions for the respective unit.

3.6. Connecting The Electronic Drive Unit



Voltages of >100 V can be present on the open electrical contacts on a running down pump. There is danger of an electrical shock if the contacts are touched.

Disconnect the plug to the electronic drive unit only once the pump is completely at rest and the electronic drive unit has been disconnected from the mains.

- ➔ Plug in connecting cable between the electronic drive unit and the turbopump. For details please see the operating instructions for the electronic drive unit.

Connecting the electronic drive unit to the turbopump

- 50 Electronic Drive Unit TCP
- 51 Male multipoint connector
- 52 Connecting cable
- 53 Bayonet plug --> turbopump

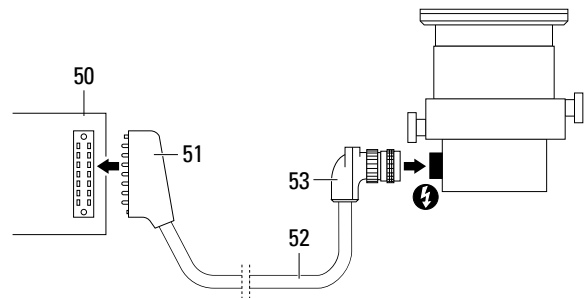

3.7. Connecting The Sealing Gas Valve

The pump types TMH 520 P and TMU 520 P (see the rating plate) are designed for connection of sealing gas.

To protect the turbopump, particularly where corrosive or dust producing processes are involved, it is necessary to use sealing gas. Connection is made via the sealing gas valve (please see "Accessories").

- ➔ Adjust the sealing gas volume (see operating instructions for the sealing gas valve, PM 800 229 BN).
- ➔ Unscrew locking screw from sealing gas connection.
- ➔ Screw in sealing gas valve with seal.
- ➔ Remove sealing gas valve blank flange.
- ➔ Flange on hose nipple (DN 16 ISO-KF-10; accessory).
- ➔ Make hose connection from pressure reducer to sealing gas valve.

Connecting the sealing gas valve

- 66 Sealing gas valve
- 67 Hose nipple
- 68 Hose connection
- 69 Pressure reducer
- 70 Gas canister

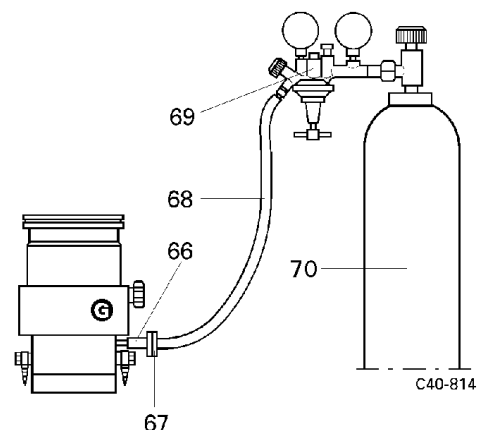

4. Operations

4.1. Before Switching ON



Turbopump rotors rotate at high speed. When the high vacuum flange is open there is a danger of injury and of objects falling into the pump. Therefore never operate the pump with open high vacuum flange.

- ➔ With water cooling: Open cooling water supply and check flow.

4.2. Switching ON

- ➔ Switch on the turbopump with switch S1 on the electronic drive unit.

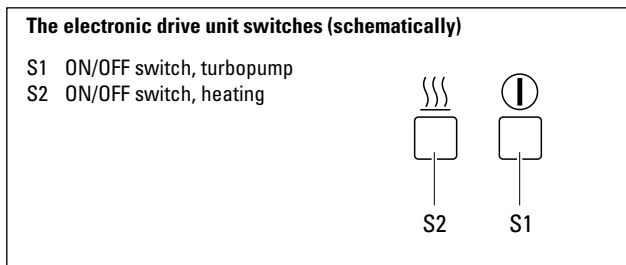

- With air cooling the cooling fan of the electronic drive unit is also switched on.
- When Pumping Station Control Unit TCS 303/304 is in use, the turbopump, the backing pump and the recycled water cooling unit (if fitted) are started at the same time.



Take care when pumping hazardous gases. Comply with all the gas manufacturer's safety instructions.

4.3. Heating (Only Pumps With Heating Sleeves)

Heating turbopumps and vacuum chambers accelerates the attainment of final pressures.

The heating period is dependent on the level of contamination and the required final pressure. Heat for at least four hours.

- ➔ Switch on turbopump heating via switch S2 on the electronic drive unit.



High temperatures are generated when turbo pump or vacuum chamber are baked out. Contact with hot parts can cause burns, even when the heating has been switched off.

Heating sleeves, pump casing and vacuum chamber should all be insulated when fitting. Do not touch heating sleeves, pump casing and vacuum chambers during baking out.

4.4. Switching OFF And Venting

To avoid contamination occurring when switching off, the pump should be vented with dry venting gas before shut-down.

- ➔ Close the vacuum safety valve in the fore-vacuum line.
- ➔ Switch off both turbopump and the electronic drive unit at the same time with switch S1.
- ➔ Open locking screw or venting valve in the venting connection (with PFEIFFER venting valves the turbopump is vented automatically).
- ➔ With water cooling: Shut off water supply.

4.5. Shutting Down For Longer Periods



Vacuum pumps are sometimes used to pump aggressive or hazardous gases. There is a danger of personal injury resulting from coming into contact with process gases. Before removing a turbopump from the system, first:

- Vent the turbopump with a neutral gas or dry air.
- Ensure that there is no residual process gas in the system nor in the feeder lines.

If the turbopump is to be shut down for more than a year:

- ➔ Remove turbopump from the system.
- ➔ Change the lubricant reservoir (see Section 6.1.).
Please note: Lubricant TL 011 must no longer be used after **2 years** of non operations.
- ➔ Close high vacuum flange and evacuate pump via the fore-vacuum flange.
- ➔ Close the high vacuum flange and evacuate the turbopump via the fore-vacuum flange.
- ➔ Vent turbopump via the venting connection with nitrogen or dry air.
- ➔ Close fore-vacuum connection by blank flanging.
- ➔ Place the pump vertically on its rubber feet.
- ➔ In rooms with moist or aggressive atmospheres, the turbopump must be air-sealed in a plastic bag together with a bag of dessicant, e.g silicagel.

Important:

If the pump has been shut down for **3 years** a bearing change must be carried out (please get in touch with PFEIFFER service).

5. What To Do In Case Of Breakdowns?

Problem	Possible Cause	Remedy
Pump doesn't start	<ul style="list-style-type: none"> • Power supply interrupted 	<ul style="list-style-type: none"> • Check fuse in the electronic drive unit • Check plug contacts on the pump and the electronic drive unit • Check supply lines
Pump doesn't attain rated rotation speed; Pump cuts out during operations	<ul style="list-style-type: none"> • Fore-vacuum pressure too high • Leak or too much gas • Rotor stiff because bearing defective • Run-up phase in the Electronic Drive Unit TCP too short • Thermal overloading caused by <ul style="list-style-type: none"> – Water cooling: Flow not safe guarded – Air cooling: Air supply restricted – Fore-vacuum pressure too high – Ambient temperature too high 	<ul style="list-style-type: none"> • Check backing pump function • Check seals • Seek leak and repair • Check bearings (noisy?): Request PFEIFFER to replace • Extend run-up phase setting time • Ensure free flow • Ensure adequate air supply • Reduce fore-vacuum pressure • Reduce ambient temperature
Pump doesn't attain final pressure	<ul style="list-style-type: none"> • Pump dirty • Leak in vacuum chamber, lines or pump 	<ul style="list-style-type: none"> • Bake out pump • If seriously contaminated: Request PFEIFFER to clean • Seek leak, starting with vacuum chamber • Repair leak
Unusual operating noises	<ul style="list-style-type: none"> • Bearings damaged • Rotor damaged • Splinter shield (if fitted) not seated firmly 	<ul style="list-style-type: none"> • Inform PFEIFFER of need for repair • Inform PFEIFFER of need for repair • Check splinter shield: Press clamping lugs away from each other (see Section 3.2.)

6. Maintenance

Important:

No liability for personal injury nor material damage will be accepted for damages and operational interruptions which have been caused by improper maintenance; in addition, all guarantees become invalid.

- You can change the lubricant reservoir yourself (see Section 6.6.).
- Your pump can be cleaned on the spot if it is not very dirty.

Your local PFEIFFER Center can advise you regarding cleaning procedures and any other maintenance and service work with might be necessary.

6.1. Changing The Lubricant Reservoir

The lubricant reservoir should be replaced at least once a year. Where extreme operating conditions or unclean processes are involved, the replacement interval should be checked with your PFEIFFER Service Center.

- ➔ Switch off the turbopump, vent to atmospheric pressure (see Section 4.4.) and allow to cool as necessary.
- ➔ If necessary, remove the turbopump from the system.
- ➔ Using a big screwdriver, unscrew the locking cover 90 on the underside of the pump; take care with the O-ring 91.
- ➔ With the help of two screwdrivers, lever out the lubricant reservoir.



Lubricant reservoirs can contain toxic substances from the medium pumped. Lubricant reservoirs must be disposed of in accordance with the respective regulations. Safety instructions data sheet on request.

Detaching the locking cover and removing the lubricant reservoir

- 90 Locking cover
- 91 O-ring
- 92 Lubricant reservoir
- 93 O-ring

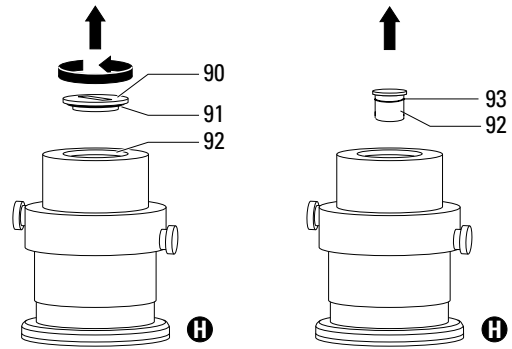

- ➔ Remove contamination on the pump and locking cover using a clean, fluff-free cloth.
- ➔ Press in new lubricant reservoir 92 up to the O-ring 93 in the pump. The lubricant reservoir comes filled with Lubricant TL 011.
- ➔ Screw in locking cover 90 with O-ring 91. The lubricant reservoir is brought into the correct axial position by the locking cover.

7. Service

Do make use of our service facilities

In the event that repairs are necessary a number of options are available to you to ensure any system down time is kept to a minimum:

- Have the pump repaired on the spot by our PFEIFFER Service Engineers;
- Return the pump to the manufacturer for repairs;
- Replace with a new value pump.

Local PFEIFFER representatives can provide full details.

Before returning:

- ➔ Please attach a clearly visible notice "Free of harmful substances" (both on the unit and also on the delivery note and any accompanying letters).

"Harmful substances" are defined in the current, local regulations; in the U.S.A. as "materials in accordance with the Code of Federal Regulations (CFR) 49 Part 173.240 Definition and Preparation".

We will carry out the decontamination and invoice this work to you if you have not attached this note. This also applies where the operator does not have the facilities to carry out the decontamination work. Units which are contaminated microbiologically, explosively or radioactively cannot be accepted as a matter of principle.

Fill out the contamination declaration

- ➔ In every case the "Contamination Declaration" must be completed diligently and truthfully.
- ➔ A copy of the completed declaration must accompany the unit; any additional copies must be sent to your local PFEIFFER Service Center.

Please get in touch with your local PFEIFFER representatives if there are any questions regarding contamination.



Decontaminate units before returning or possible disposal. Do not return any units which are microbiologically, explosively or radioactively contaminated.

Returning contaminated units

If contaminated have to be returned for maintenance/repair, the following instructions concerning shipping must be followed:

- ➔ Neutralise the pump by flushing with nitrogen or dry air.
- ➔ Seal all openings to the air.
- ➔ Seal pump or unit in suitable protective foil.
- ➔ Ship units only in appropriate transport containers.

Please note:

Repair orders are carried out according to our general conditions of sale and supply. If repairs are necessary, please send the pump to your nearest PFEIFFER Service Center.

Contact addresses and telephone hotline

Contact addresses and telephone numbers can be found on the back cover of these operating instructions.

8. Technical Data

Feature	Unit	TMH 520 TMU 520	TMH 520 TMU 520
Connection nominal diameter			
Inlet		DN 100 ISO-K DN 100 CF-F	DN 160 ISO-K DN 160 CF-F
Outlet		DN 25 ISO-KF G 1/4"	DN 25 ISO-KF G 1/4"
Electronic Drive Unit		TCP 380/TCP 600	
Final pressure, backing pump	mbar	< 5	< 5
Max. permissible rotor temperature	°C	90	
Permissible heat radiation power	W	10,5	
Pumping speed for			
Nitrogen N ₂	l/s	300	500
Helium He	l/s	400	500
Hydrogen H ₂	l/s	400	480
Compression ratio for			
N ₂		> 10 ¹²	> 10 ¹²
He		5 · 10 ⁷	5 · 10 ⁷
H ₂		5 · 10 ⁶	5 · 10 ⁶
Max. fore-vacuum pressure			
N ₂	mbar	16	16
He	mbar	14	14
H ₂	mbar	7	7
Max. gas throughput ¹⁾			
N ₂	mbar l/s	3	3
He	mbar l/s	4	4
Final pressure ²⁾			
with rotary vane vacuum pump	mbar	5 · 10 ⁻¹¹	5 · 10 ⁻¹¹
with diaphragm vacuum pump	mbar	5 · 10 ⁻¹¹	5 · 10 ⁻¹¹
Nominal rotation speed	1/min	50000	50000
Stand-by rotation speed	1/min	33000	33000
Run-up time (up to 90% of the rated rotation speed with TCP 380/TCP 600)	min	7/5	7/5
Cooling type, standard		water	
Max. cooling water requirements with water at 15 °C ³⁾	l/h	50	50
Cooling water temperature	°C	5 - 25 option	
Air cooling		option	
Permissible ambient temperature with air cooling	°C	0 - 35	
Heating power consumption	W	100	100
Noise level	dB (A)	< 50	< 50
Lubricant		TL 011	
Permissible magnetic field	mT	5,0	5,0
Weight	kg	12,5	13

- 1) Measured with rotary vane vacuum pump 1,5 m³/h, higher gas throughputs with reduced rotation speed.
- 2) In accordance with DIN 28 428 the final pressure of a turbomolecular pump is that pressure which is attained in a measuring dome 48 hours after baking out.
- 3) With max. gas throughput.

ⓐ Only pump types TMH 520 P / TMU 520 P (see the rating plate).

8.1. Dimensions

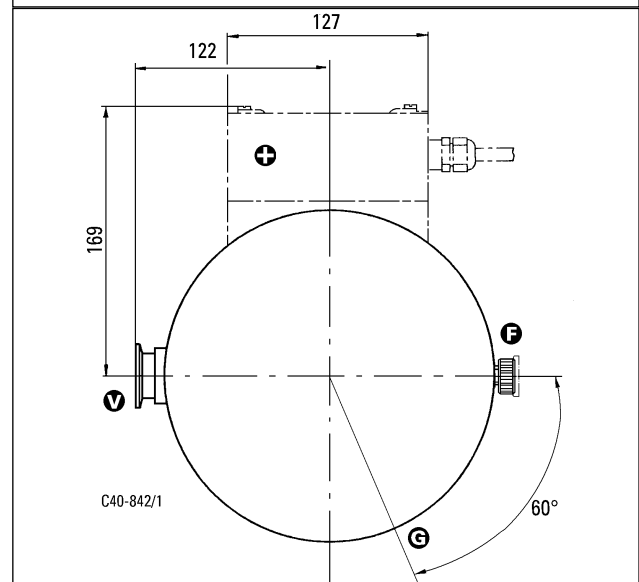
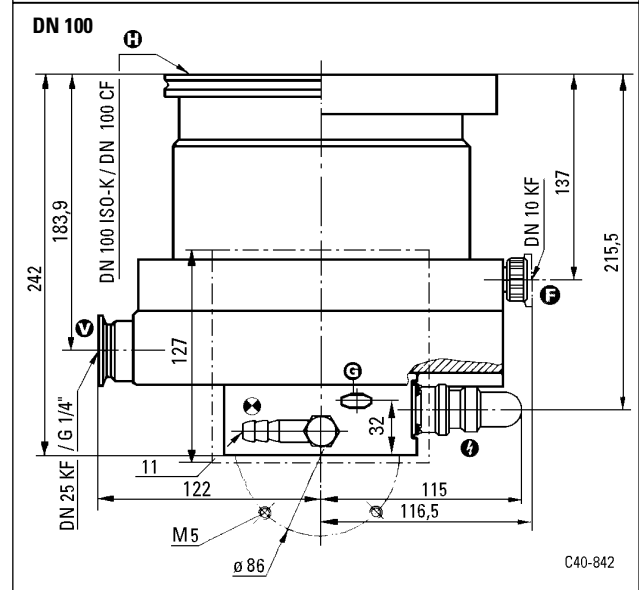
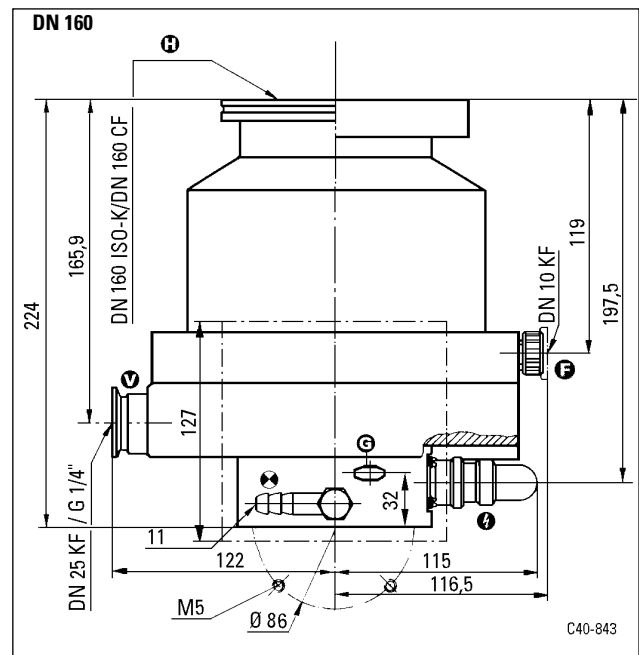

9. Accessories

Description	Size	Number	Comments/ Operating instructions	Order Quantity
Electronic Drive Unit TCP 380 TCP 600	100 - 240 V; 50/60 Hz 100 - 240 V; 50/60 Hz	PM C01 490 PM C01 320	PM 800 188 BN PM 800 234 BN	
Connecting cable Turbopump - TCP 380 Turbopump - TCP 600 Heating sleeve Vibration compensator, TMH TMU TMH TMU	3 m 3 m 115 V/230 V DN 100 ISO-K DN 100 CF-F DN 160 ISO-K DN 160 CF-F	PM 011 232 -X PM 031 803 -T PM 043 445 -T PM 006 459 AX PM 006 488 -X PM 006 492 -X PM 006 493 -X	Other lengths on request Other lengths on request	
Splinter shield	DN 100 DN 160	PM 006 125 AX PM 006 771 -X		
Protective grill	DN 100 DN 160	PM 006 596 -R PM 006 823		
Sealing ring for TMH	DN 100 ISO-K DN 160 ISO-K	PF 303 110 -T PF 303 116 -T		
Collar flange with retaining ring TMH	DN 100 ISO-F DN 160 ISO-F	PF 307 110 -T PF 307 116 -T		
CU seal (10 pieces), TMU	DN 100 CF DN 160 CF	PF 501 410 -T PF 501 416 -T		
Set of screws, TMU	DN 100 CF DN 160 CF	PF 505 003 -T PF 505 003 -T		
Pumping Station Controller TCS 130 TCS 304 R TCS 304 R	205, 220, 380, 400, 415 V; 50/60 Hz 100 - 240 V; 50/60 Hz 208 - 415 V; 50/60 Hz	PM C01 551 PM C01 537 PM C01 537	PM 800 205 BN PM 800 192 BN (Only with thermistor print PM 021 721-X) PM 800 263 BN	
Fore-Vacuum Safety Valve TVV 001	115 V 230 V	PM Z01 206 PM Z01 205		
Sealing gas valve (only for pump types TMH/TMU 520 P) Hose nipple for the sealing gas valve	DN 10 ISO-KF DN 16 ISO-KF-10	PM Z01 142 PF 144 020	PM 800 229 BN	
Components for cooling				
Cooling Water Monitor TCW 002	110 V; 50/60 Hz 220 V; 50/60 Hz 240 V; 50/60 Hz	PM C00 131 PM C00 130 PM C00 132	PM 800 133 BN	
Connection component set for the TCW 002		PM 006 802-T P 4161 300 2R		
Dirt trap	R 3/8"			
Recycled Water Cooling Unit TZK 400	230 V; 50 Hz	PM Z01 245	PM 800 369 BN	
Component set for the air cooling	230 V; 50/60 Hz 115 V; 50/60 Hz	PM Z01 221 PM Z01 222		
Components for venting				
Venting Control Unit TCF 103	110/220 - 240 V; 50/60 Hz	PM C01 356	PM 800 196 BN	
Venting and Valve Control Unit TCV 103	110/220 - 240 V; 50/60 Hz	PM C01 366	PM 800 196 BN	
Venting valve,: open after pressure equalisation: (only with TCF 103 or TCV 103) TVF 012	G 1/8" DN 10 ISO-KF	PM Z01 082 PM Z01 080	PM 800 126 BN	
Venting valve, closed after pressure equalisation: TVF 012	G 1/8" DN 10 ISO-KF	PM Z01 087 PM Z01 085	PM 800 126 BN	
Mains Power Failure Venting Unit TSF 010	110 V; 60 Hz, G 1/8" 110 V; 60 Hz, DN 10 ISO-KF 220 V; 50/60 Hz, G 1/8" 220 V; 50/60 Hz, DN 10 ISO-KF 240 V; 50/60 Hz, G 1/8" 240 V; 50/60 Hz, DN 10 ISO-KF	PM Z01 110 PM Z01 017 PM Z01 111 PM Z01 010 PM Z01 112 PM Z01 016 PM Z01 106 PM Z01 105 PM Z00 121	PM 800 032 BN	
Venting Valve TSF 012	G 1/8" DN 10 ISO-KF	PM Z01 106 PM Z01 105 PM Z00 121	PM 800 168 BN	
Drier (filled with zeolite) Venting flange TTV 001	DN 10 ISO-KF	PM 033 737-T	PM 800 022 BN	

10. Spare Parts

Pos.	Description	Pieces	Size	Number	Comments	Ordering Quantity
	Spare Parts TMH/TMU 520					
	Set of seals	1		PM 063 176-T		
6	Rubber feet	4		P 3695 700 ZE		
16	USIT-ring	4	U 12,7/18x1,5	P 3529 142		
17	QUAD-ring	1	VI 10,82x1,78	P 4081 630 C		
91	O-ring	1	Vi 38x3	P 4070 621 PV		
92	Lubricant reservoir	1		PM 063 265-T		
	Spare Parts, Air Cooling					
	Air cooling set	1	230 V; 50/60 Hz	PM Z01 221		
		1	115 V; 50/60 Hz	PM Z01 222		
36	Fan	1	230 V	P 5099 251-R7		
		1	115 V	P 5099 251-R1		
36a	Finger protector	2		P 5099 251 Z4		
36b	Buffer	4		P 3695 705 LB		

When ordering accessories and spare parts please be sure to state the full part number. When ordering spare parts please state additionally the unit type and unit number (see rating plate). Please use this list as an order form (by taking a copy).

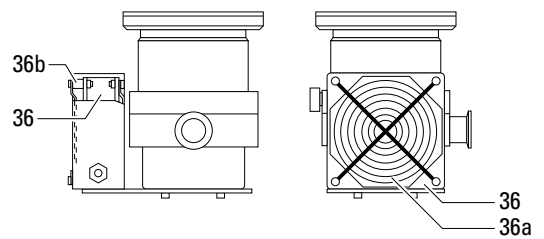
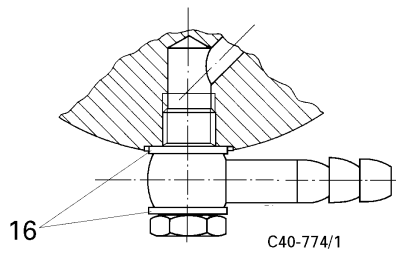
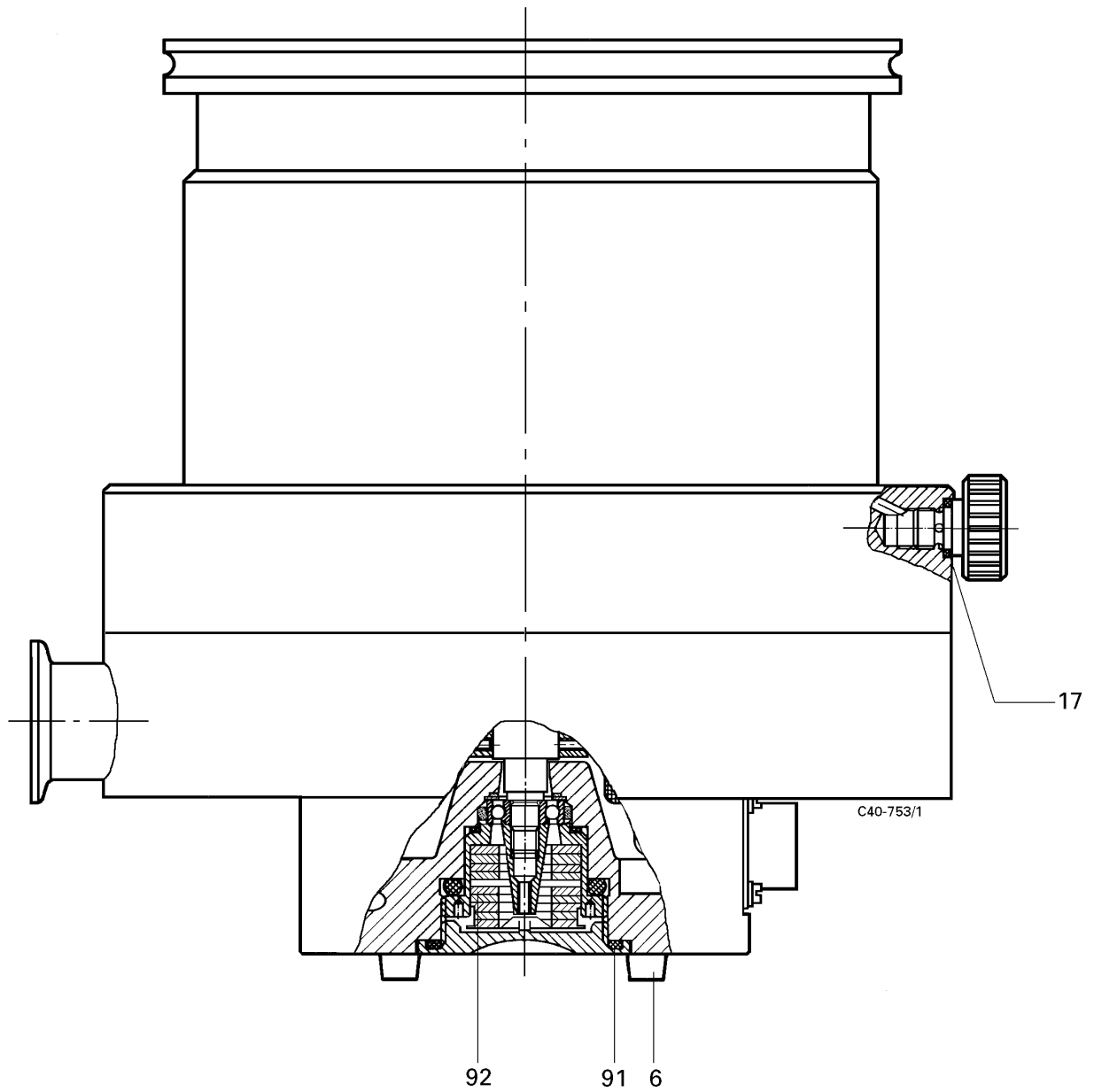

Declaration of Contamination of Vacuum Equipment and Components

The repair and/or service of vacuum components will only be carried out if a correctly completed declaration has been submitted. Non-completion will result in delay.

The manufacturer could refuse to accept any equipment without a declaration.

This declaration can only be completed and signed by authorised and qualified staff:

1. Description of component:

- Equipment type/model: _____
- Code No.: _____
- Serial No.: _____
- Invoice No.: _____
- Delivery Date: _____

2. Reason for return:

3. Equipment condition

- Has the equipment been used?
yes no
- What type of pump oil was used?

- Is the equipment free from potentially harmful substances?
yes (go to section 5)
no (go to section 4)

4. Process related contamination of equipment

- toxic yes no
- corrosive yes no
- microbiological hazard*) yes no
- explosive*) yes no
- radioactive*) yes no
- other harmful substances yes no

*) We will not accept delivery of any equipment that has been radioactively or microbiologically contaminated without written evidence of decontamination!

Please list all substances, gases and by-products which may have come into contact with the equipment:

Tradename Product name Manufacturer	Chemical name (or Symbol)	Danger class	Precautions associated with substance	Action if spillage or human contact
1.				
2.				
3.				
4.				
5.				

5. Legally Binding Declaration

I hereby declare that the information supplied on this form is complete and accurate. The despatch of equipment will be in accordance with the appropriate regulations covering Packaging, Transportation and Labelling of Dangerous Substances.

Name of Organisation: _____

Address: _____ Post code: _____

Tel.: _____

Fax: _____ Telex: _____

Name: _____

Job title: _____

Date: _____ Company stamp: _____

Legally binding signature: _____

Herstellererklärung Manufacturer's Declaration

im Sinne folgender EU-Richtlinien:
pursuant to the following EU directives:

- **Maschinen/Machinery 98/37/EG**
- **Elektromagnetische Verträglichkeit/Electromagnetic Compatibility 89/336/EWG**
- **Niederspannung/Low Voltage 73/23/EWG**

Hiermit erklären wir, daß das unten aufgeführte Produkt zum Einbau in eine Maschine bestimmt ist und daß deren Inbetriebnahme so lange untersagt ist, bis festgestellt wurde, daß das Endprodukt den Bestimmungen der EU-Richtlinie 98/37/EG, Anhang II B entspricht.

Wir bestätigen Konformität mit der EU-Richtlinie über elektromagnetische Verträglichkeit 89/336/EWG und der EU-Niederspannungsrichtlinie 73/23/EWG.

We hereby certify that the product specified below is intended for installation in a machine which is forbidden to be put into operation until such time as it has been determined that the end product is in accordance with the provision of EU Directive 98/37/EEC, Annex II B.

We certify conformity with EU Electromagnetic Compatibility Directive 89/336/EEC and EU Low Voltage Directive 73/23/EEC.

Produkt/Product:

TMH 520 / TMU 520

TMH 520 P / TMU 520 P

Angewendete Richtlinien, harmonisierte Normen und angewendete, nationale Normen:

Guidelines, harmonised standards, national standards in which have been applied:

**EN 292-1, EN 292-2, EN 294,
EN 1012-2, EN 61010**

Unterschrift/Signature:



Pfeiffer-Vacuum GmbH
Emmeliusstrasse 33
35614 Asslar
Germany

(W. Dondorf)
Geschäftsführer
Managing Director

Herst.I./2000

Zentrale/Headquarters

Pfeiffer Vacuum GmbH
 Emmeliusstrasse 33
 D-35614 Asslar
 Telefon 06441/802-0
 Telefax 06441/802-202
 Hotline 06441/802-333
 Internet:
<http://www.pfeiffer-vacuum.de>

Argentina

ARO S.A., Casilla de Correo 4890,
 1000 Buenos Aires, telephone +54 / 1 331 3918,
 telefax +54 / 1 331 3572

Australia

Balzers Australia Pty. Ltd., Level 1,
 3, Northcliff Street, Milsons Point, NSW 2061,
 telephone +61 / 2 9954 1925, telefax +61 / 2 9954 1939

Austria

Pfeiffer Vacuum Austria GmbH
 Diefenbachgasse 35, A-1150 Wien,
 telephone +43 / 1 8941 704, telefax +43 / 1 8941 707
 Service Hotline: +43 / 1 8941704

Branch Office, Czech Republic

Pfeiffer Vacuum Austria GmbH, Branch Prague
 Zvonarska 885
 CZ-156 00 Praha 5
 telephone + 420/2 900 42981
 telefax + 420/2 579 23014

Belgium / Luxemburg

Pfeiffer Vacuum Belgium N.V./S.A.
 Luxemburgstraat 5, B-1940 Temse
 telephone +32 / 3 710 5920, telefax +32 / 3 710 5929
 Service Hotline: +32 / 3 710 5922

Brazil

Elmi Tec
 Assistencia Técnica e Representação S/C Ltda.
 Rua Bernadino de Compos, 551
 CEP 04620-002 São Paulo, SP - Brasil
 telephone +55 / 11 532 0740
 telefax +55 / 11 535 3598

Chile

BERMAT S.A., Coyancura 2283, piso 6
 Providencia, P.O. Box 9781, Santiago
 telephone +56 / 2 231 8877,
 telefax +56 / 2 231 4294

Colombia

Arotec Colombiana S.A., Carrera 15 No.38-17
 P.O. Box 050 862, Santafe de Bogota / D.C.
 telephone +57 / 1 288 7799, telefax +57 / 1 285 3604

Denmark

Pfeiffer Vacuum Scandinavia AB, Vesterengen 2,
 DK-2630 Taastrup,
 telephone +45 / 43 52 38 00
 telefax +45 / 43 52 38 50

France

Pfeiffer Vacuum France SAS
 45, rue Senouque, BP 139 F-78531 BUC Cedex
 telephone +33 / (0)1 30 83 04 00
 telefax +33 / (0)1 30 83 04 04

Germany

Pfeiffer Vacuum GmbH,
 Emmeliusstrasse 33, D-35614 Asslar
 telephone +49 / 6441 802 400
 telefax +49 / 6441 802 399
 Service Hotline: +49 / 6441 802 333

Great Britain

Pfeiffer Vacuum Ltd.
 Bradbourne Drive, Tilbrook,
 Milton Keynes, MK7 8AZ, United Kingdom
 telephone +44 / 1 908 373 333
 telefax +44 / 1 908 377 776

Greece

Analytical Instruments S.A., 1 Mantzarou St.,
 GR-15451 Athens,
 telephone +30 / 1 674 8973
 telefax +30 / 1 674 8978

India

Pfeiffer Vacuum India Ltd.
 25-E Nicholson Road, Tarbund
 Secunderabad 500 009,
 telephone +91 / 40 775 0014, telefax +91 / 40 775 7774

Israel

ODEM Scientific Applications,
 2 Bergman Street, Science based park
 Rehovod
 telephone +972 8 9366 101,
 telefax +972 8 9366 102

Italy

Pfeiffer Vacuum Italia S.p.a.
 Via San Martino, 44 I-20017 RHO (Milano)
 telephone +39 / 2 93 99 051, telefax +39 / 2 93 99 05 33

Japan

Hakuto Co. Ltd., C.P.O. Box 25,
 Vacuum & Scientific Instruments Division
 Tokyo Central 100-91,
 telephone +81 / 3 32 258 910
 telefax +81 / 3 32 259 009

Korea

Pfeiffer Vacuum Korea Ltd., 3F Haein Building 453,
 Dokok-Dong, Kang Nam-Ku, Seoul, 135-270
 telephone +82 / 2 3461 0671/5
 telefax +82 / 2 3461 0676

Netherlands

Pfeiffer Vacuum Nederland BV
 Veldzigt 30a, NL-3454 PW De Meern,
 telephone +31 / 30 6666050, telefax +31 / 30 6662794

Peru

Ing. E. Brammert s.r.l., José Pardo 182,
 Apartado 173, PE-18 Miraflores,
 telephone +51 / 1 445 8178
 telefax +51 / 1 445-1931

Poland

Softtrade Sp.z.o.o, ul. Malwowa 35,
 PL-60-175 Poznan, telephone +48 / 61 8677 168,
 telefax +48 / 61 8677 111

Portugal

Unilaser Lda, Taguspark
 Núcleo Central, sala nº 268, Estrada Cacém-
 Porto Salvo, P-2780 Oeiras
 telephone +351 / 1 421 7733
 telefax +351 / 1 421 7744

Singapore

APP Systems Services Pte. Ltd, 2 Corporation Road
 06-14 Corporation Place, Singapore 618494,
 telephone +65 / 268 2024, telefax +65 / 268 6621

Spain

Tecnovac
 Tecnologia de Vacío S.L., Ronda de Poniente, 6 Bajo F
 Centro Empresarial Euronova
 E-28760 Tres Cantos (Madrid)
 telephone +34 / 91 804 11 34,
 telefax +34 / 91 804 30 91

Sweden

Pfeiffer Vacuum Scandinavia AB
 Johanneslundsvägen 3
 S-194 61 Upplands Väsby
 telephone +46 / 590 748 10
 telefax +46 / 590 748 88

Switzerland

Pfeiffer Vacuum Schweiz S.A.
 Förrlibuckstraße 30, CH-8005 Zürich
 telephone +41 / 1 444 2255,
 telefax +41 / 1 444 2266

South Africa

Labotec Pty Ltd., P.O. Box 6553,
 Halfway House
 1685 Midrand
 telephone +27 / 11 315 5434
 telefax +27 / 11 315 5882

Taiwan

S & T Hitech Ltd. Hsinchu office
 No. 103, Hsien Chen 11th Street, Jubei City,
 HsinChu County, Taiwan, R.O.C.
 (zip/postal code: 302)
 telephone +886 / 3 554 1020
 telefax +886 / 3 554 0867

Thailand

S & T Enterprises (Thailand) Ltd.
 18th Floor, Chokchai Int'l Bldg.
 690 Sukhumvit Road
 Klongton, Klongtoey
 Bangkok 10110
 telephone +662 / 259 4623
 telefax +662 / 259 6243

U.S.A.

Pfeiffer Vacuum, Inc.
 24 Trafalgar Square
 Nashua, NH 03063-1988
 USA
 telephone +1/ 603 578 6500
 telefax +1/ 603 578 6550

Venezuela

Secotec S.A., Apartado 3452, Caracas 1010-A,
 telephone +58 / 2 573 8687
 telefax +58 / 2 573 1932

Other countries

AVI - Applied Vacuum Industries GmbH
 Leginglenstrasse 17A; CH-7320 Sargans
 Switzerland
 telephone +41 / 81 710 03 80
 telefax +41 / 81 710 03 81

Scope of represented countries

Armenia, Azerbaijan, Bangladesh, Belarus, Bulgaria,
 Cambodia, Estonia, Georgia, Hong Kong, Kazakhstan,
 Kingdom of Nepal, Kirghizia, Latvia, Lithuania,
 Maldavia, Philippines, P.R. China, Rumania, Russia,
 Tajikistan, Turkmenistan, Ukraine, Uzbekistan, Vietnam

A.E.M.S.

Advanced Equipment Materials and Systems
 P.O. Box 25
 Föhrenweg 18
 FL-9496 Balzers
 telephone +41 / 75 380 0550
 telefax +41 / 75 380 0551

Scope of represented countries

Bahrain, Egypt, Iraq, Iran, Jordan, Kuwait, Lebanon,
 Lybia, Oman, Pakistan, Saudi-Arabia, Sudan, Syria,
 Turkey, United Arab Emirates, Yemen